

REV. NO.	DESCRIPTION	DATE
Various		09/05/2018

General Notes:

- A template shall be provided to fit the location of the anchor bolts and conduits that project out of the concrete footing.
- Anchor bolt templates shall be ASTM A-36 with a minimum thickness of 1/4" and both top and bottom need not be galvanized.
- Footing shall be constructed with at least two service entry conduits, some may require more. See the plans for locations and number of conduits required, any unused conduit shall be capped on both ends.
- Electrical conduit or conduit sleeves shall be in accordance with Section 802, "Electrical Conduit."
- If a breakaway device is to be installed, the footing shall be as close to ground level as possible to assure the proper action of the breakaway device and to prevent damage to the footing or underside of an impacting vehicle.
- If specified, the footing may be extended extra length above or below grade, see the plans for location and length. Also the vertical and spiral bar length along with conduit length may be adjusted accordingly.
- Provide 3 inches of clearance from outside edges, 3 inches of clearance from bottom, and 3 inches clearance from top of footing for all reinforcing steel.
- If anchor bolt data is not specified in the plans, the bolt size and placement for new poles shall be in accordance with the approved shop drawings. Anchor bolts shall be installed to fit the pole assembly base plate.
- If the footing is constructed by a contractor other than the signal contractor, the following additional requirements will apply:
(A) An anchor bolt space plate shall be installed.
(B) The conduit sleeves for the power conductors shall be 2 inch rigid galvanized steel or Schd 40 PVC and extend approximately 6 inches from the edge of the footing and be capped at both ends, unless the conduit system is designed to extend to another point of termination.
(C) The size of the anchor bolt and the bolt circle dimensions shall be as shown in the plans and detailed herein.
- If the Contractor elects to install Cable-In-Duct (CID) trench conduit prior to constructing the footing, the CID conduit may be placed in concrete footing without a conduit sleeve. If the trench CID is to be installed after the footing is constructed, a conduit sleeve will be required. The conduit sleeve shall be sized to accommodate the CID specified in the plans. Example: 2 inch CID requires a 3 inch diameter sleeve.
- The anchor bolts, conduit sleeves, templates, ground rod, ground wire, clamp and the conduit for the ground wire will not be measured for payment but shall be included in the unit price bid for the footing materials. The electrical conduit shall be measured for payment and paid for at the unit price bid for the electrical conduit of the size/type specified in the plans in accordance with Section 802, "Electrical Conduit."
- Install a conduit coupling, adaptor, or compression coupling if necessary to connect conduits of dissimilar materials.
- The anchor bolt projection shall be either:
(A) "A4" (+ 1/2") for shoe base.
(B) 3 1/2" minimum to 4" maximum for transformer base.
(C) As required for double nut leveling.
- The Contractor shall construct the top of the signal pole footings level to avoid the use of shims when installing the light poles on the footings.
- Electrical conductors shall be in accordance with Section 834, "Electrical Conductors For Traffic Signals."
- All concrete shall be Class "A" and reinforcing steel shall be in accordance with ASTM A615 Grade 60 or AASHTO M-31 Grade 60.
- If rock is encountered, the footing shall extend a minimum of one footing diameter into solid rock.
- Bond anchor bolt to rebar cage with a #4 AWG bare stranded copper conductor, using the Cadweld method. Use listed mechanical connectors rated for embedding in concrete.
- All breakaway bases shall meet the breakaway requirements of the 2013 Edition of the AASHTO "Standard Specifications For Structural Supports For Highway Signs, Luminaires and Traffic Signals," and shall have been tested by FHWA-approved methods. All bases shall have been structurally tested to resist 150% of the design moment.
- Ground rod may be located in adjacent signal pull box.

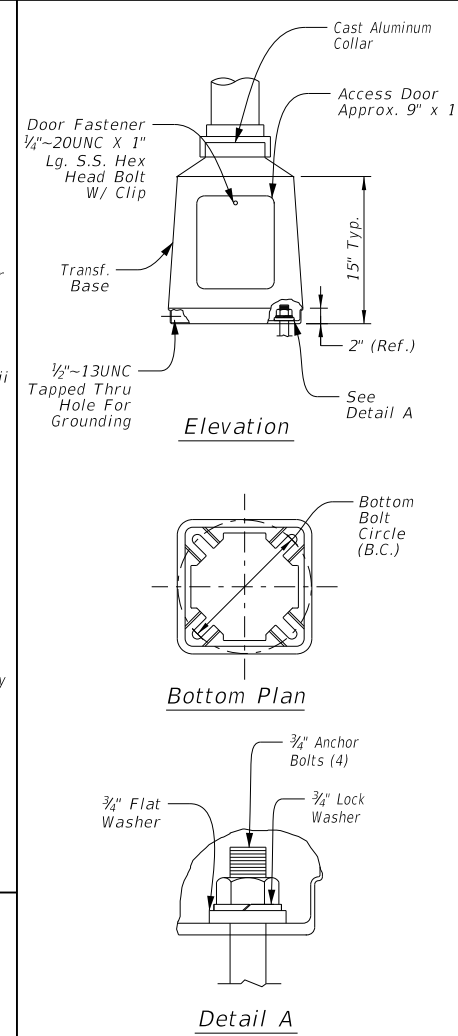

Transformer Base Table

Base Type	Bottom B.C.	
	Min.	Max.
PED	12"	14"

Transformer Base Bolt Circle Table
Pedestal Pole Details

Conduit Radii Schedule

Nominal Conduit or Sleeve Diameter (Inches)	Minimum Radius (Inches)
1/2, 3/4, 1, 1 1/2	12
1 1/2	18
2	24
2 1/2, 3	30
4	36
5	48

Conduit Radii Schedule

Basis of Payment

Item No.	Item	Unit
804(A)	Structural Concrete	CY
804(B)	Reinforcing Steel	LB

Approved By Bridge Engineer: *St. A.* Date: **9-14-18**
 Approved By Traffic Engineer: *Cy. E.* Date: **9/18/18**

DOT

Traffic Standard
Traffic Signal
Mast Arm Pole
and Pedestal Pole
Footing Details

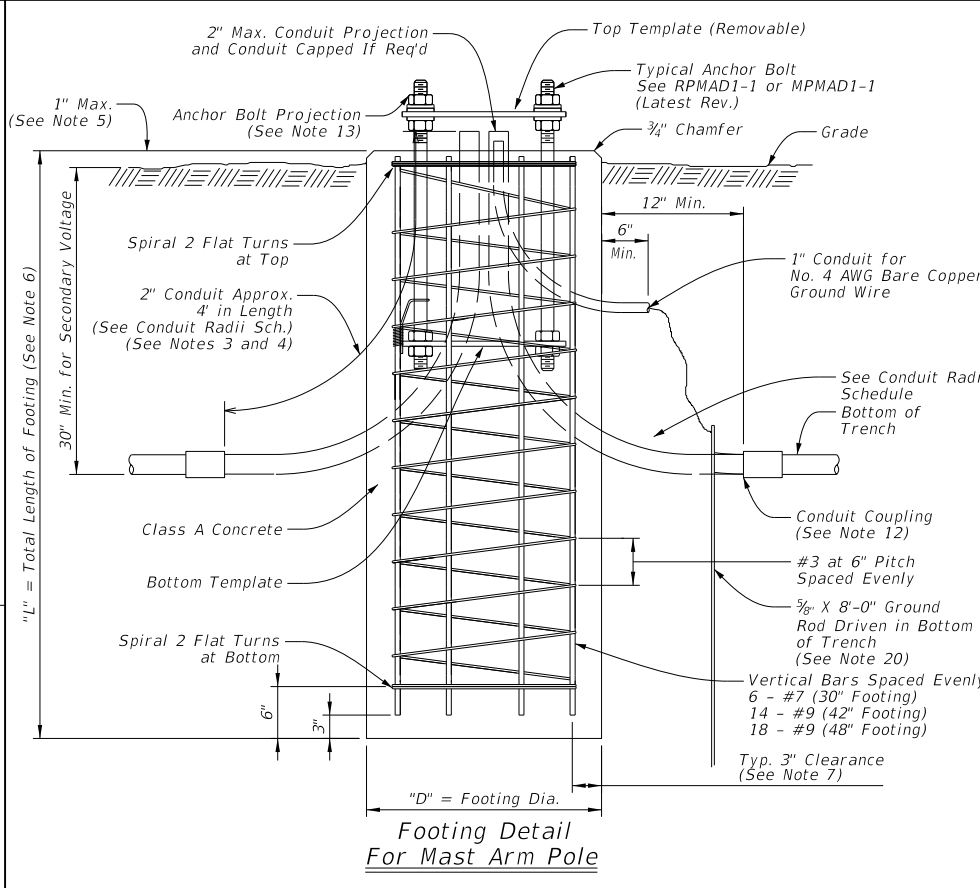

Signal Mast Arm Footing Data

Single Mast Arm Length (FT)	Design No.	Dimensions			Quantities		
		Footing Dia. "D" (IN)	Footing Length "L" (FT)	Bar #9 Length (FT)	Bar #3 Spiral Length (FT)	Reinforcing Steel (LBS)	Structural Conc. (CY)
Up to 40	S-40	42	12'-6"	12'-0"	264	670.4	4.5
45 - 55	S-55	48	15'-0"	14'-6"	363	1,023.8	7.0

Dual Mast Arm Footing Data

Longest Dual Mast Arm Length (FT)	Design No.	Dimensions			Quantities		
		Footing Dia. "D" (IN)	Footing Length "L" (FT)	Bar #9 Length (FT)	Bar #3 Spiral Length (FT)	Reinforcing Steel (LBS)	Structural Conc. (CY)
Up to 40	S-40	42	13'-0"	12'-6"	273	697.7	4.6
45 - 55	S-55	48	16'-6"	16'-0"	396	1128.0	7.7

Pedestal Pole Footing Data

Pole Height (FT)	Design No.	Dimensions			Quantities		
		Footing Dia. "D" (IN)	Footing Length "L" (FT)	Bar #7 Length (FT)	Bar #3 Spiral Length (FT)	Reinforcing Steel (LBS)	Structural Conc. (CY)
5	P-1	30	2'-0"	1'-6"	44	34.9	0.36
8	P-2	30	2'-6"	2'-0"	50	43.4	0.45
10	P-3	30	2'-6"	2'-0"	50	43.4	0.45
12-15	P-4	30	3'-0"	2'-6"	56	51.9	0.55

* - Length includes 2 flat turns at top and bottom.

Footing Design Data

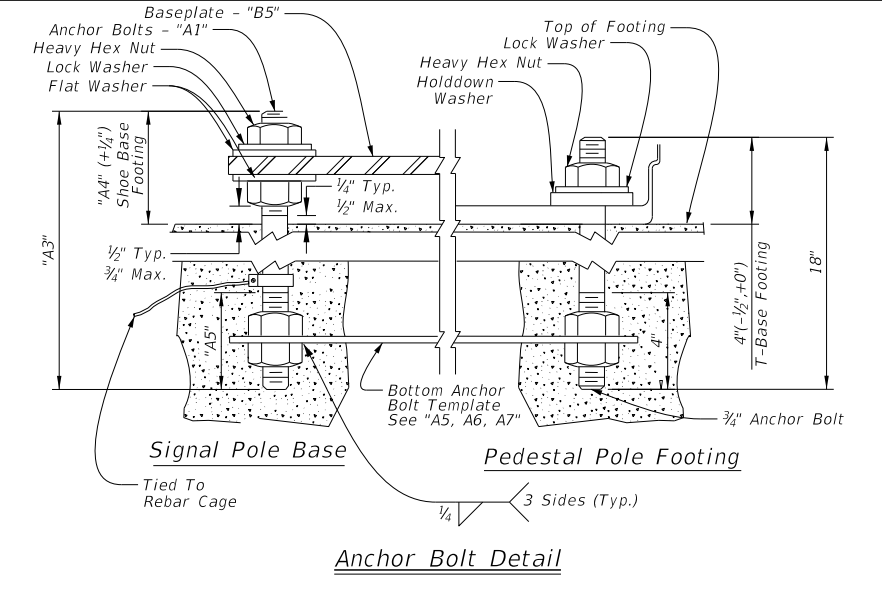

Anchor Bolt Detail

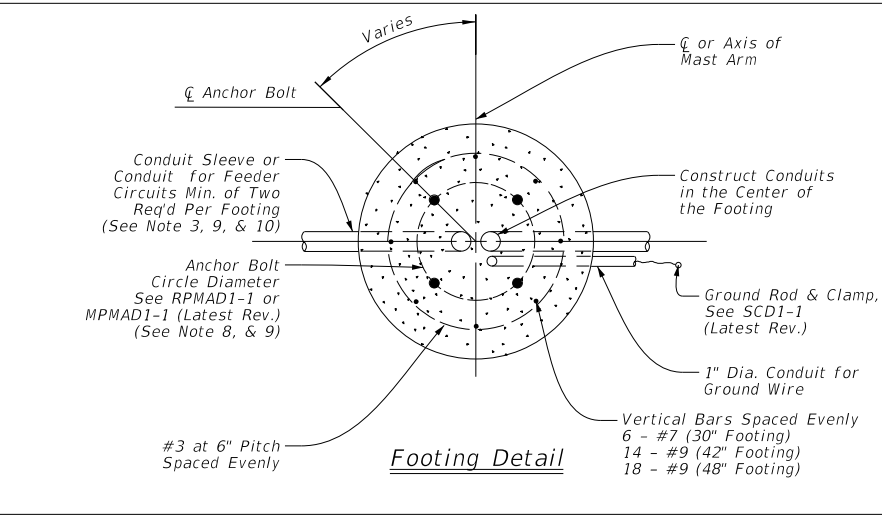

Footing Detail

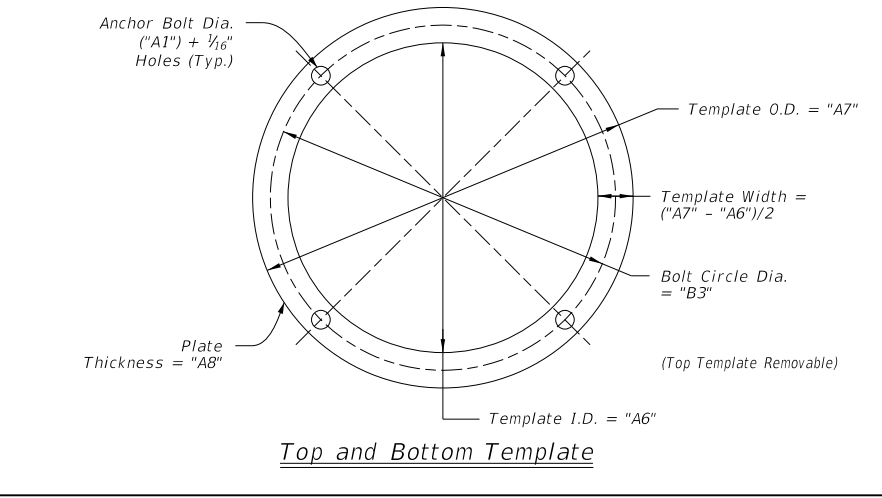

Top and Bottom Template

Anchor Bolt Fabrication Tolerances Table

Dimension	Tolerance
Length	± 1/2"
Threaded Length	± 1/2"
Galvanized Length (If Required)	- 1/4"

Anchor Bolt Tolerances