

CADBE

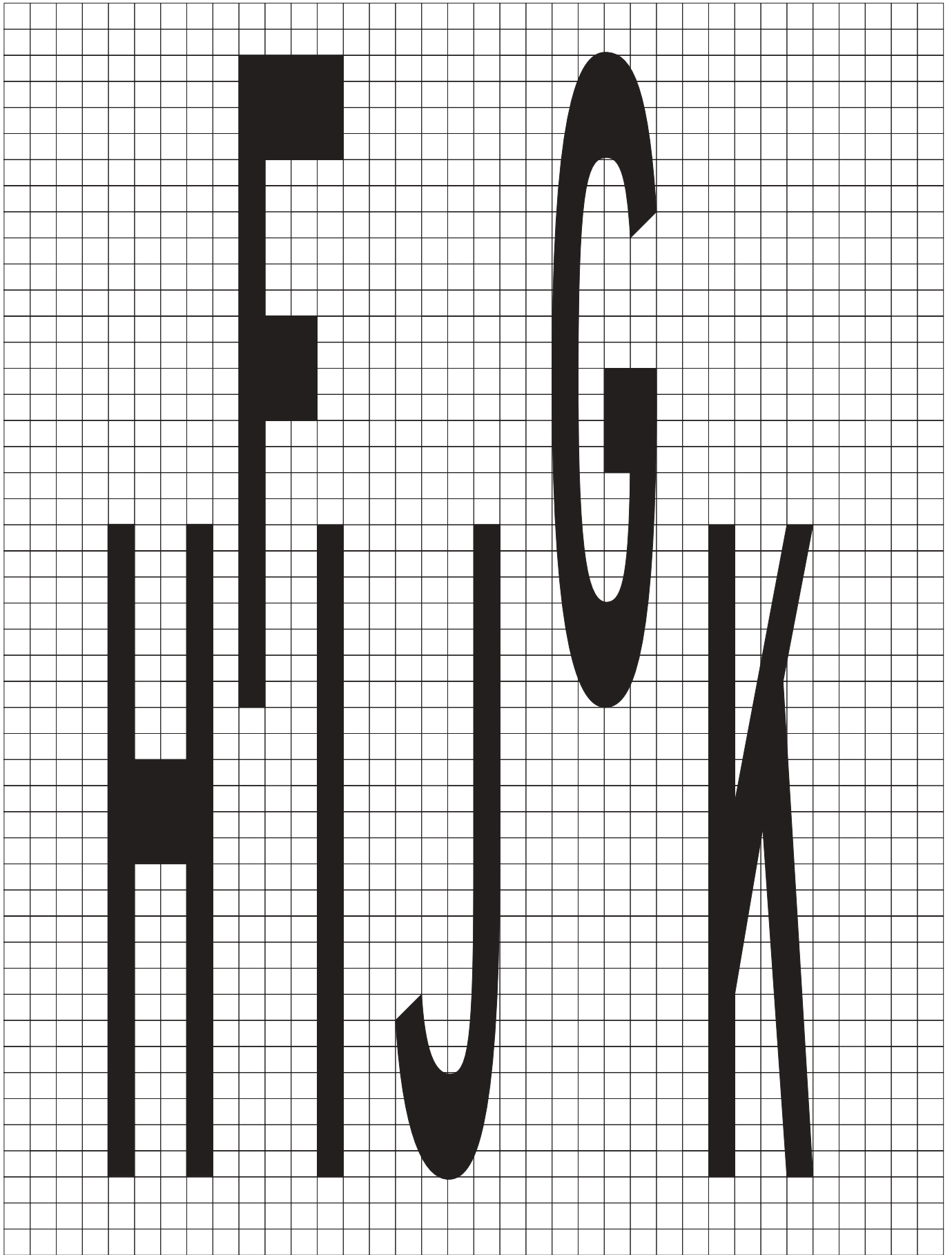

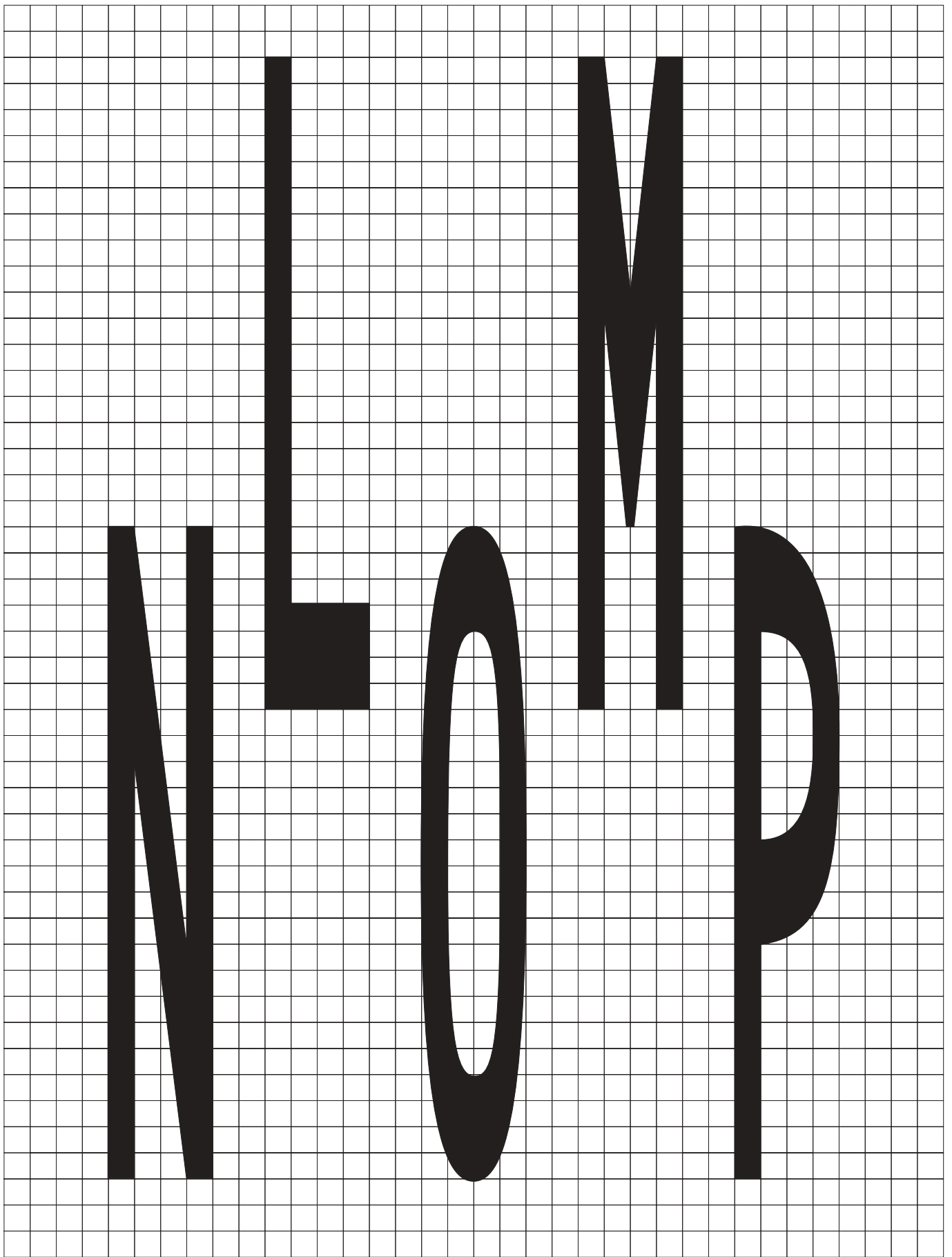

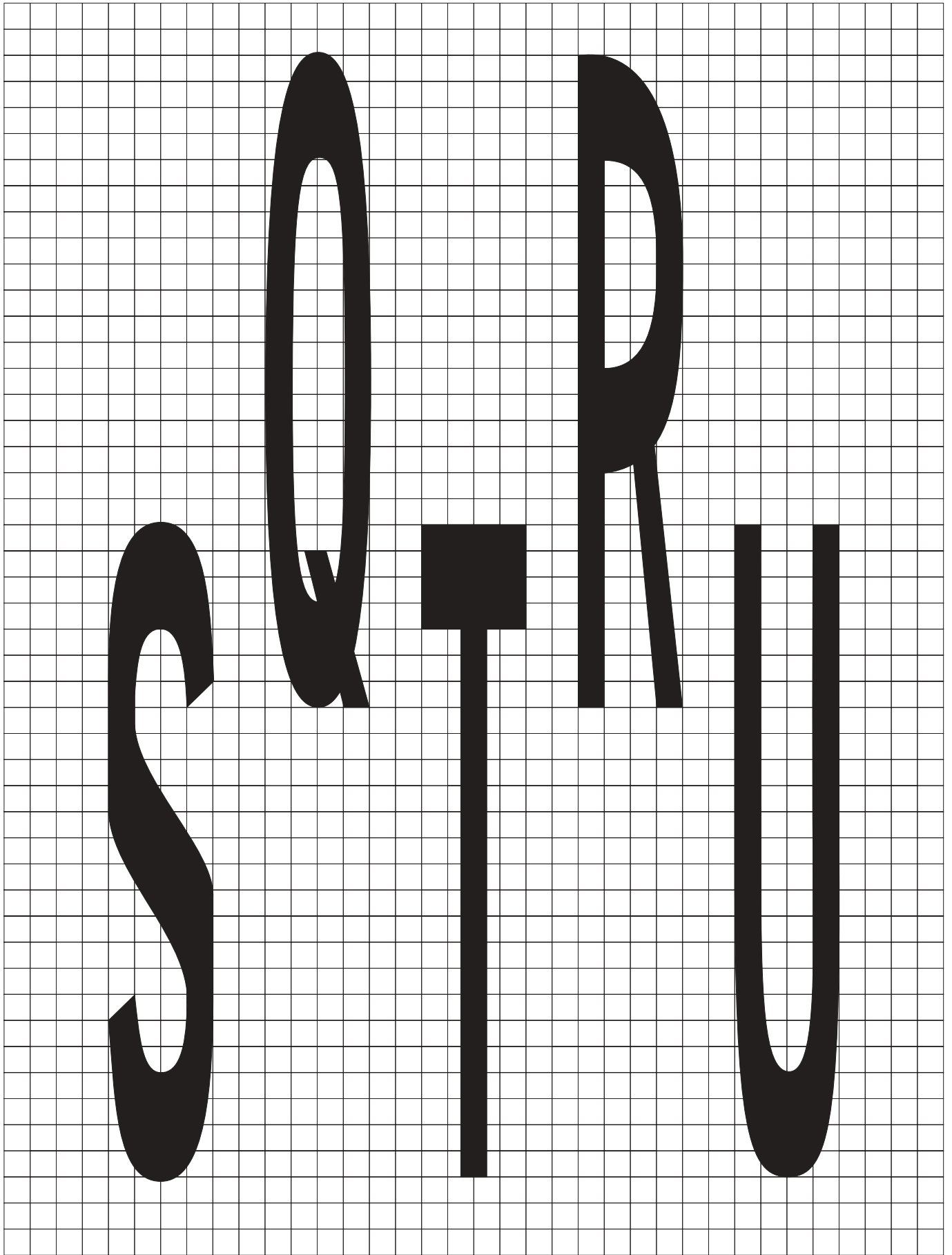

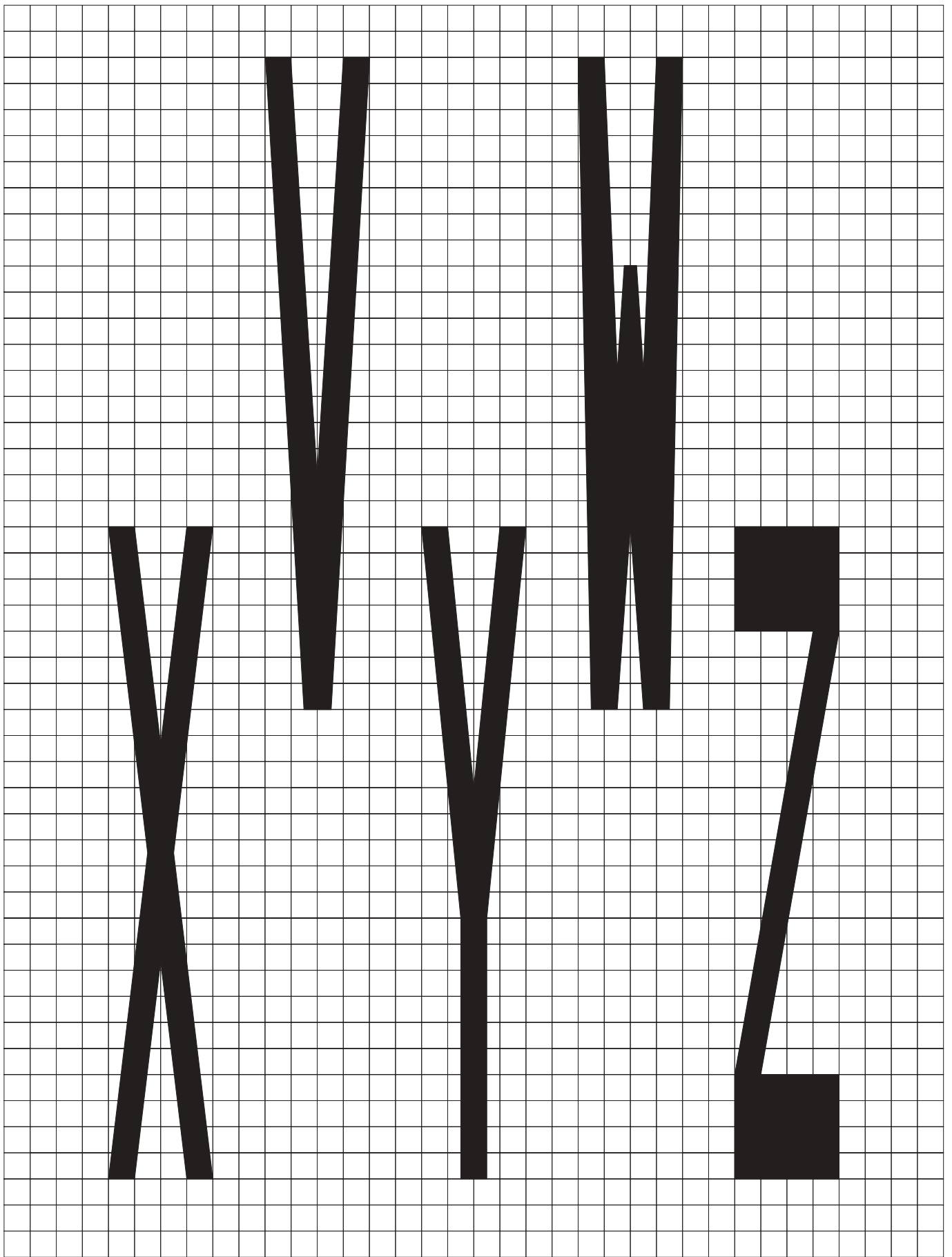

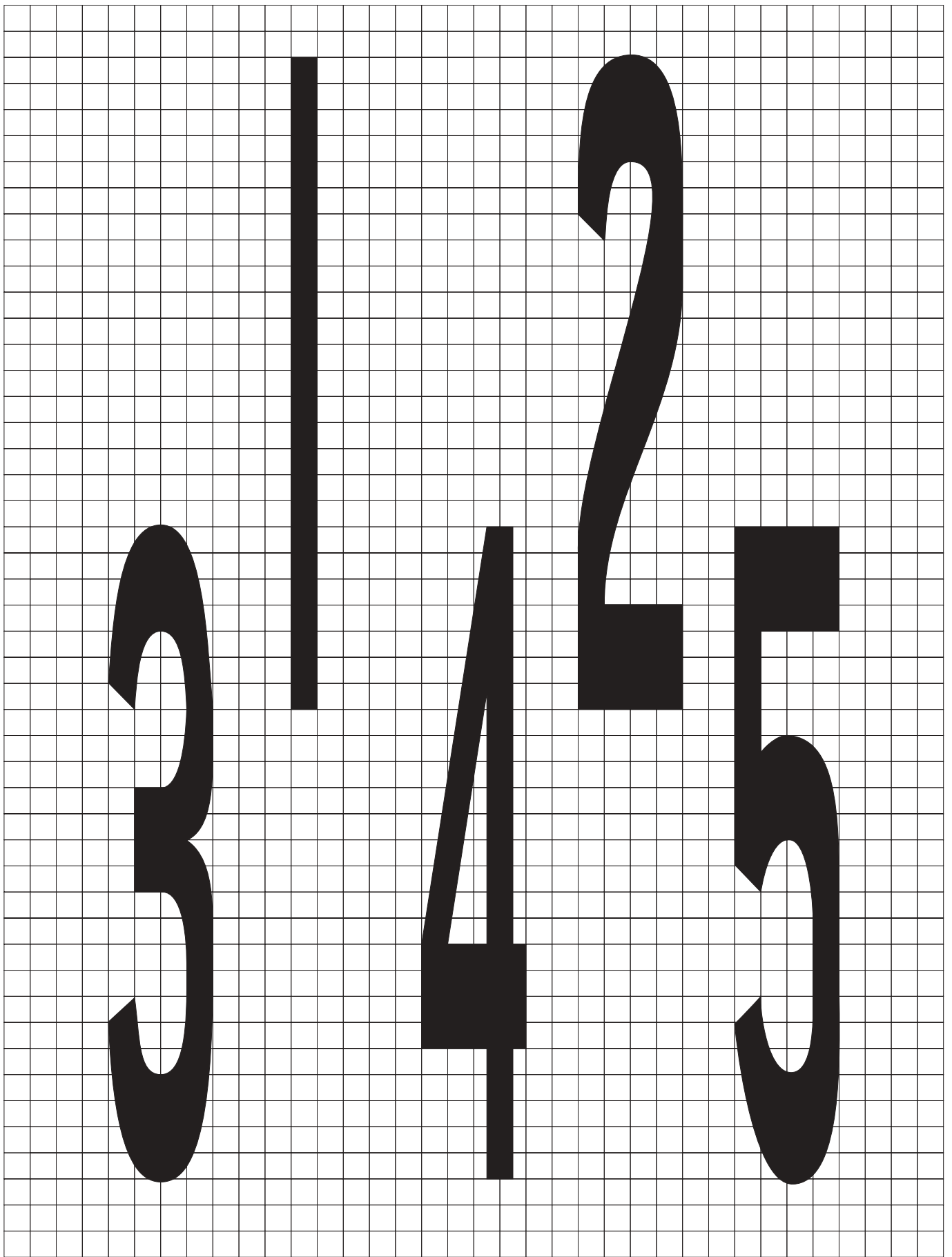

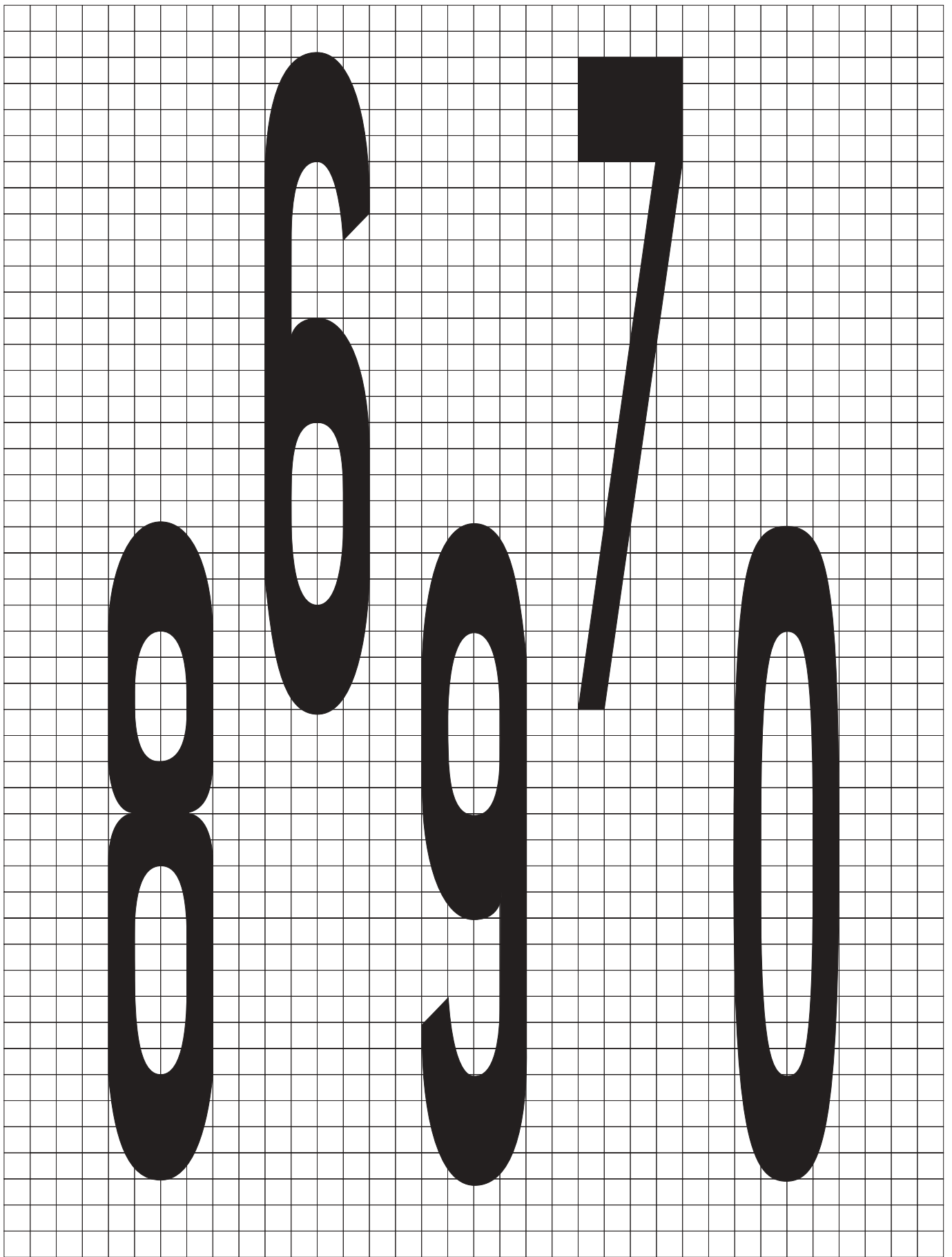

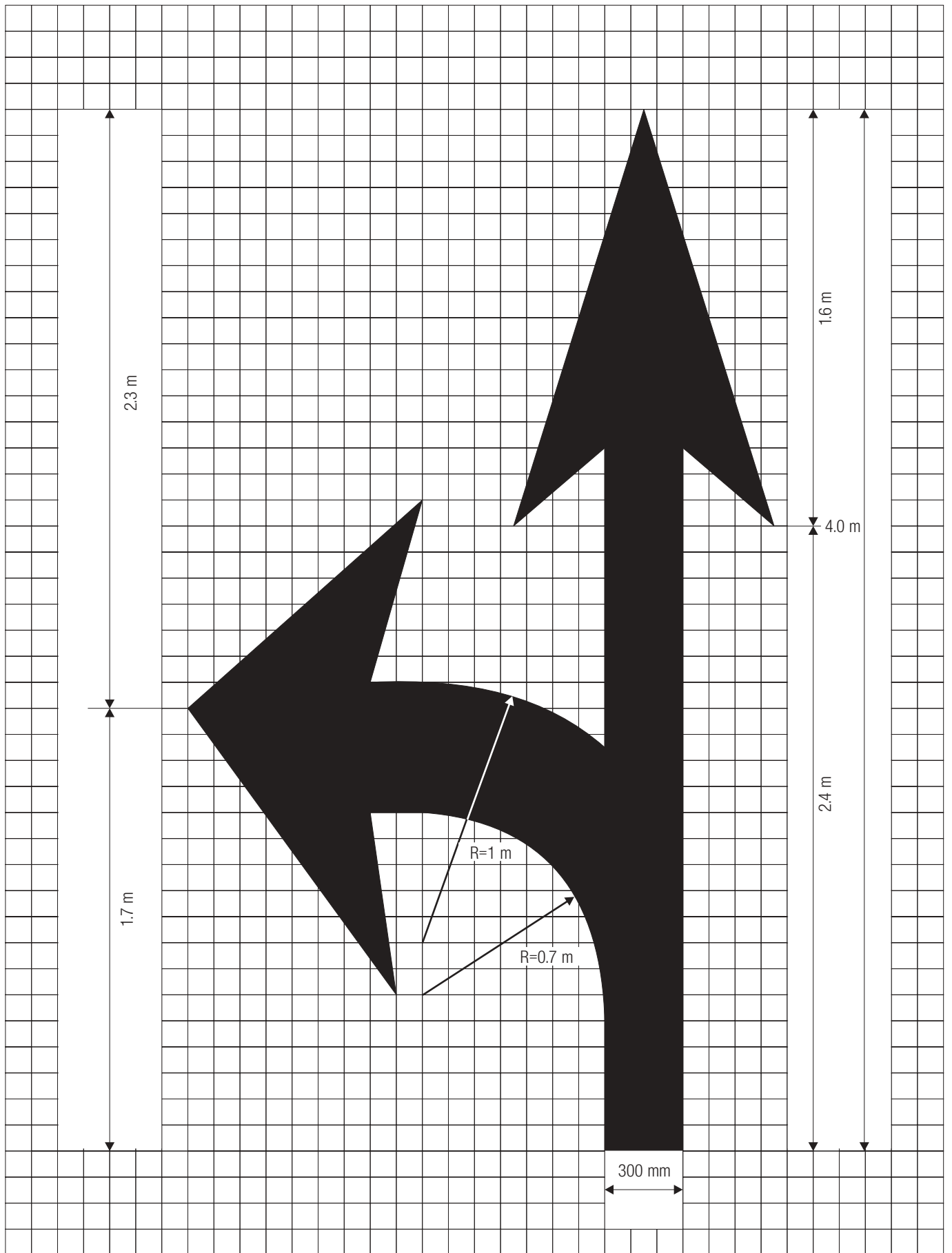

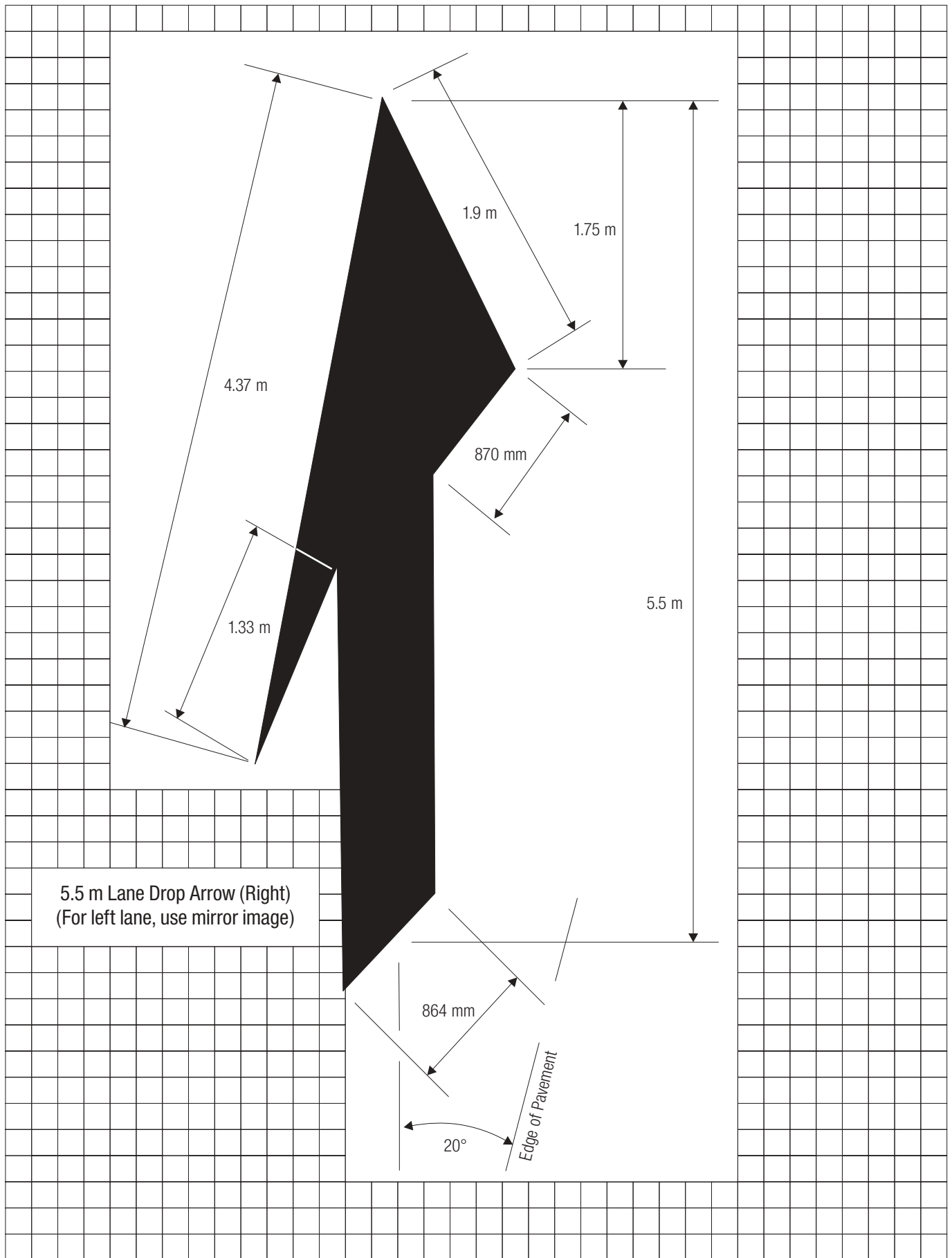

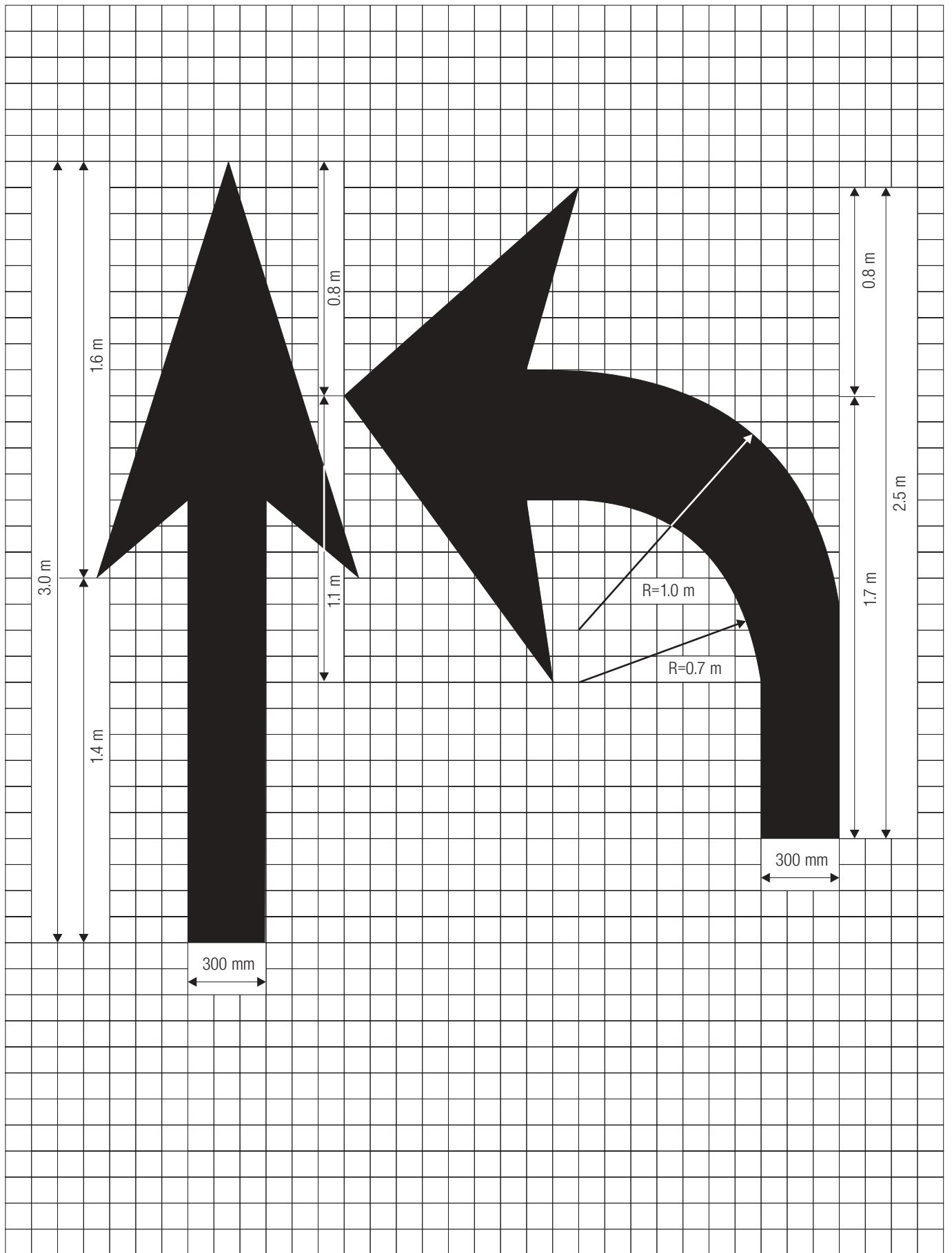

Freeway, Expressway and Ramp Pavement Arrow

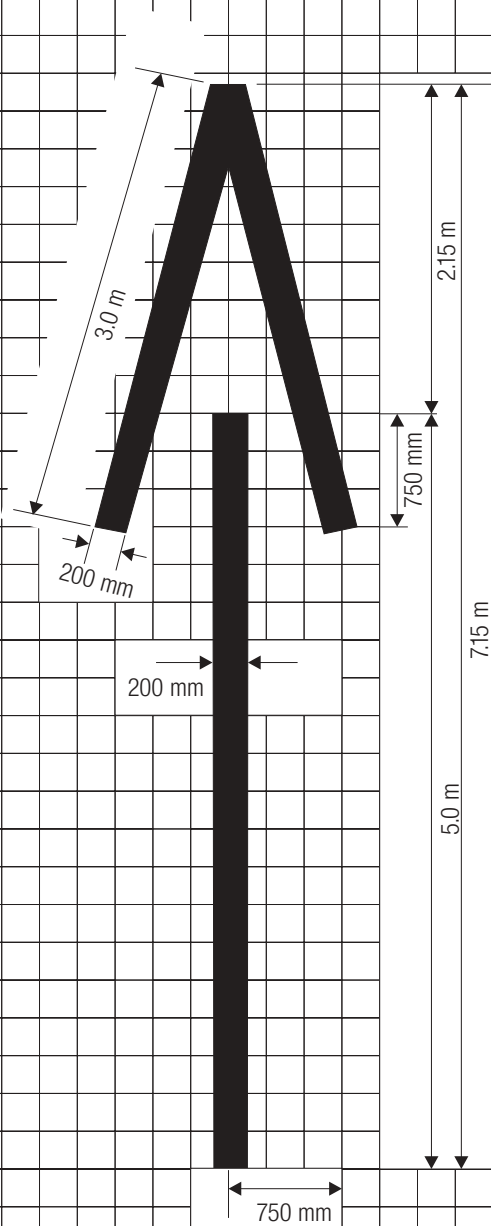

Preferential Lane Symbol

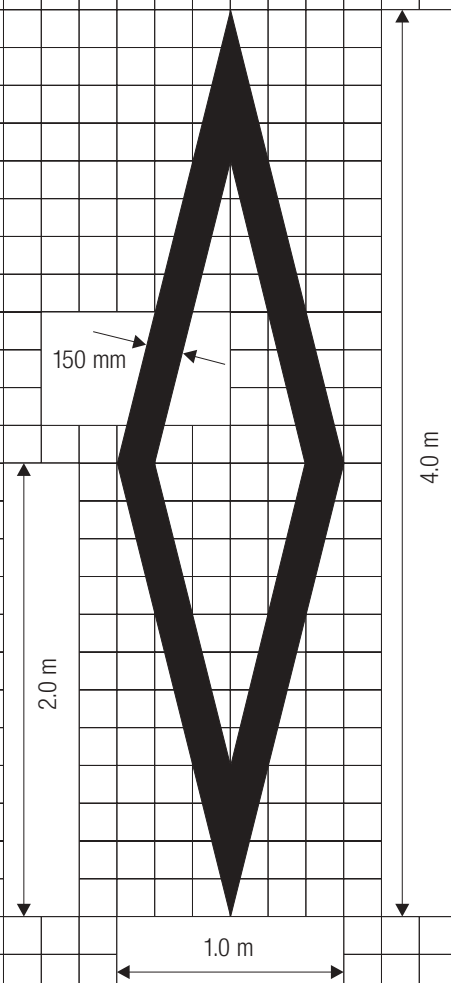

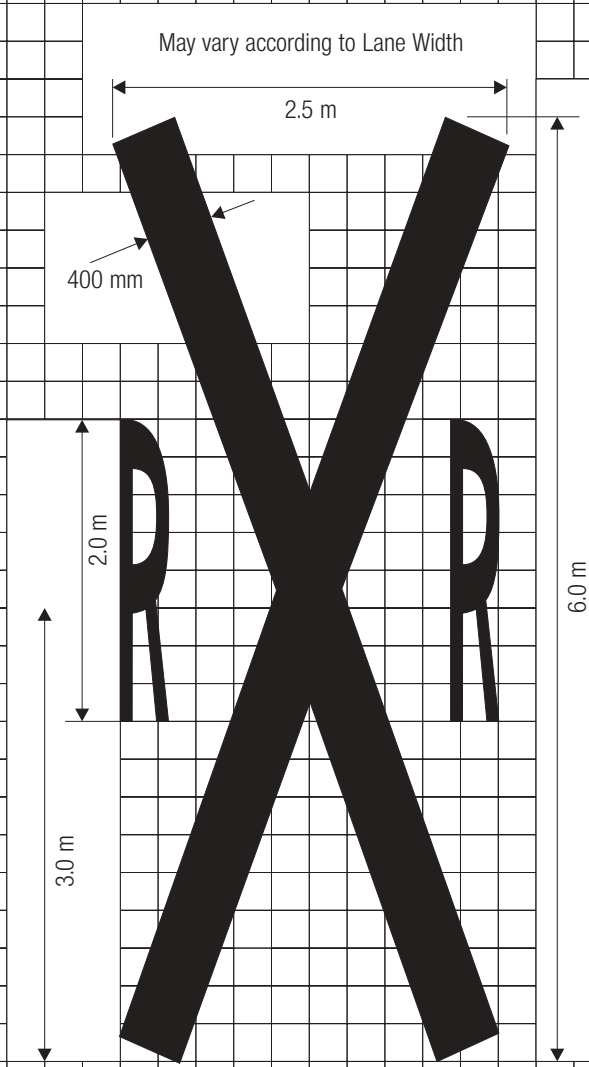

Railroad Crossing Symbol

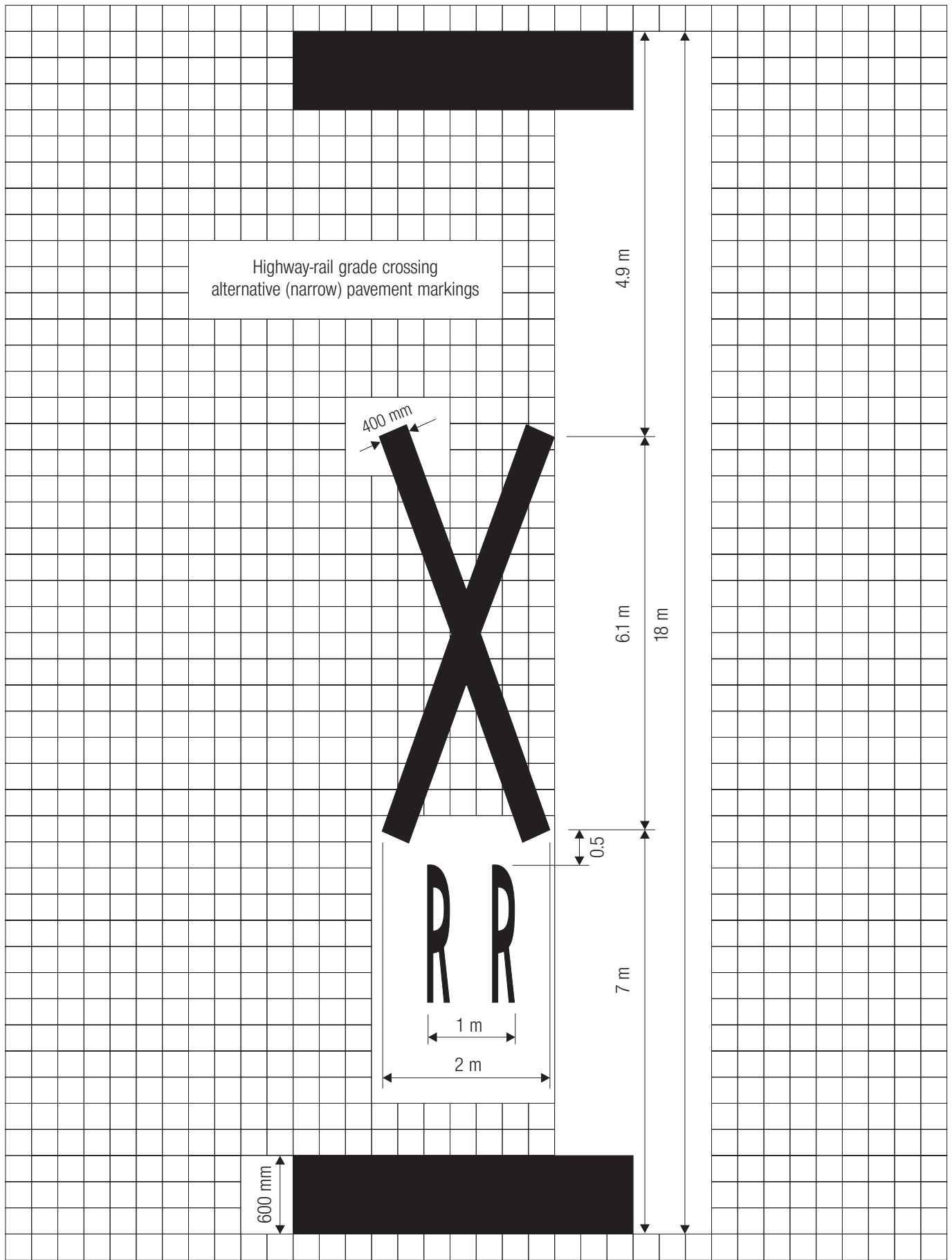

Bicycle Symbols

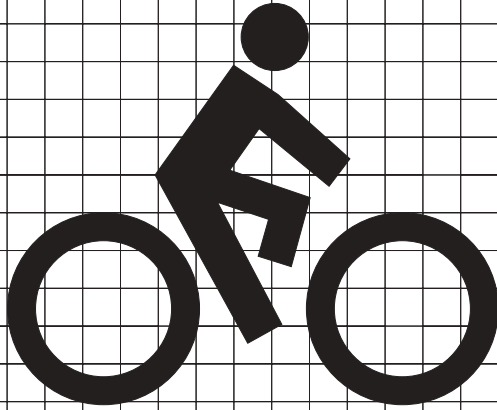

Bicycle Trail

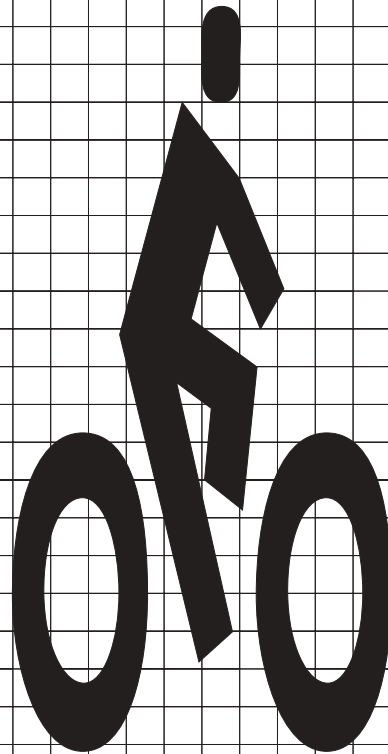

Designated Bicycle Lane

SCHOOL

3,480 mm

3,000 mm

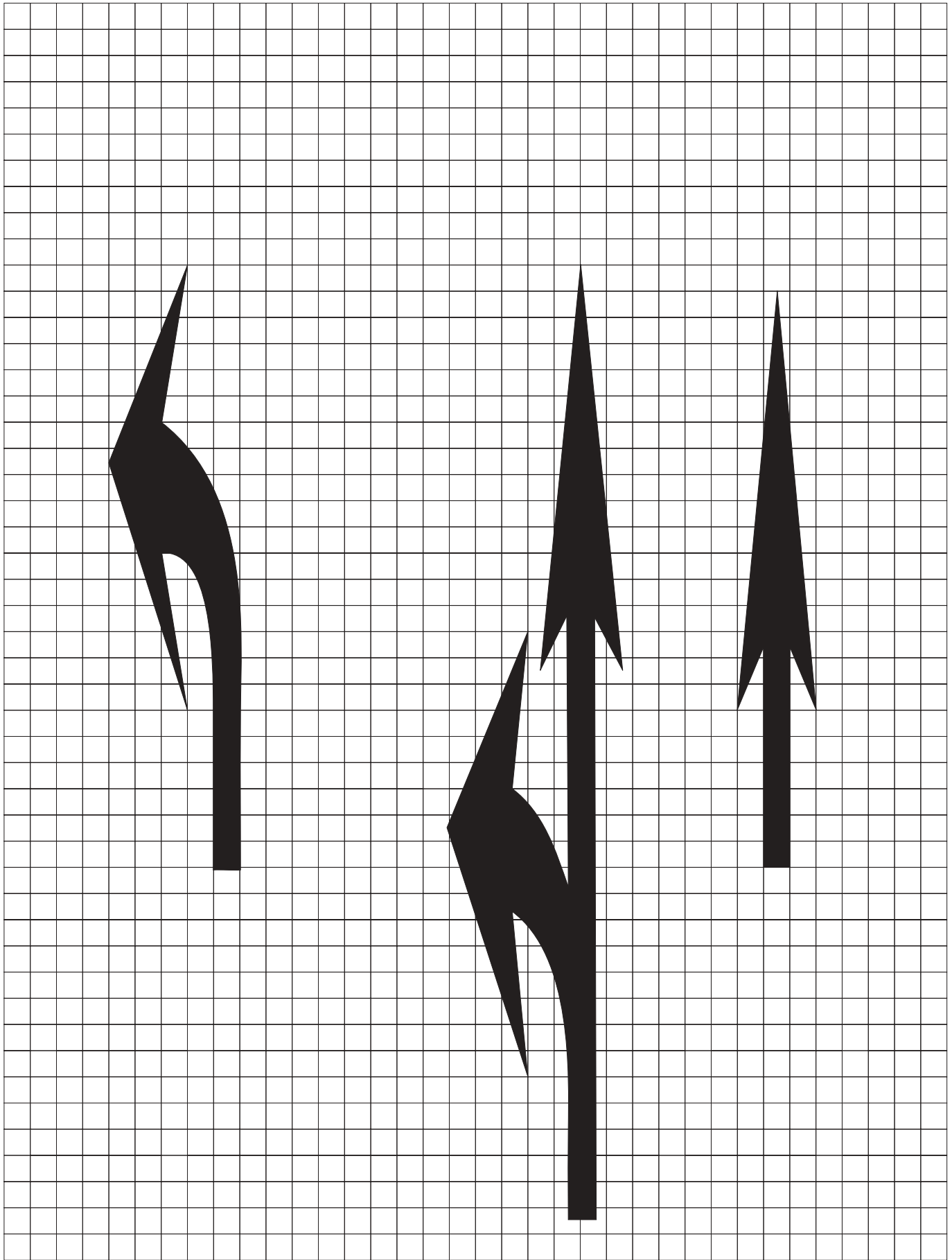

Through Lane-Use Arrow
2.9 m (9.5 ft)

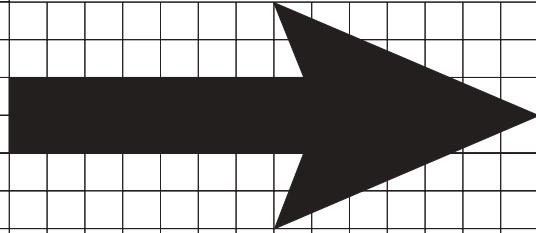

Turn and Through Lane-Use Arrow
3.9 m (12.75 ft)

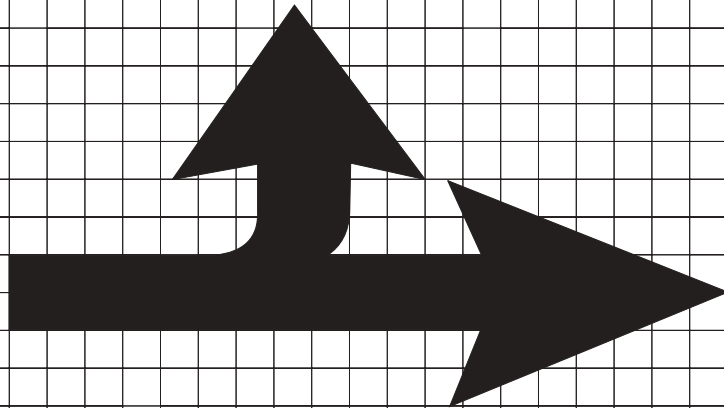

Wrong-Way Arrow Using Retroreflective Raised Pavement Markers

5 Spaces at 1.4 m (4.75 ft)

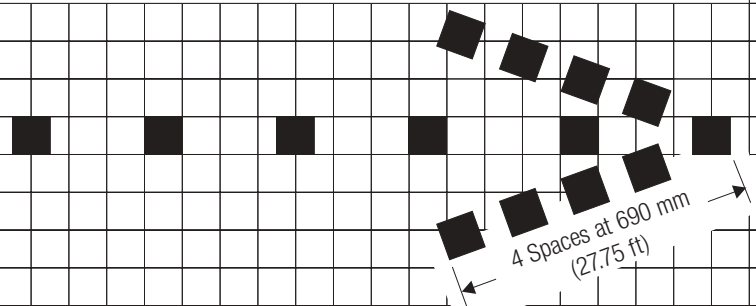

4 Spaces at 690 mm
(2.75 ft)

Turn Lane-Use Arrow

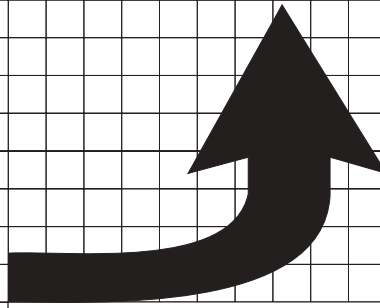

2.4 m (8 ft.)

Wrong-Way Arrow

7.1 m (23.5 ft.)

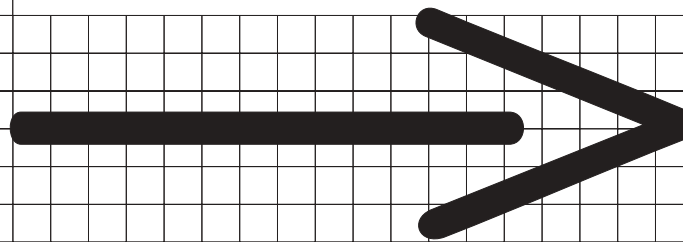

Lane-Reduction Arrow

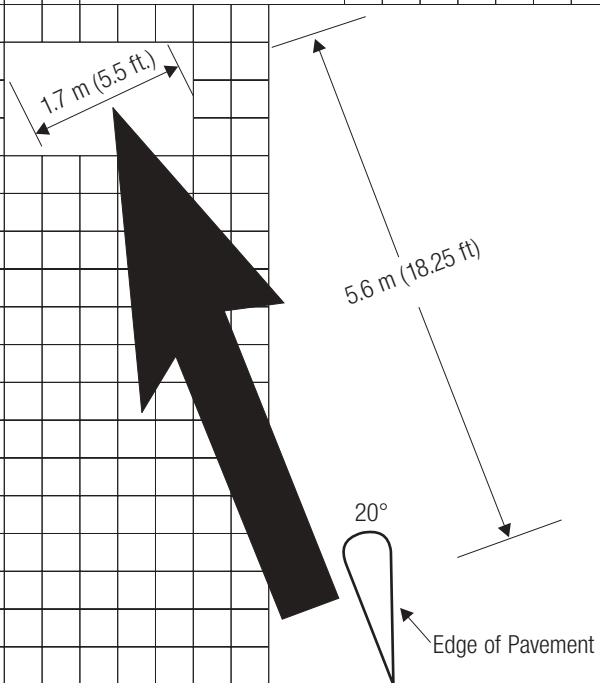

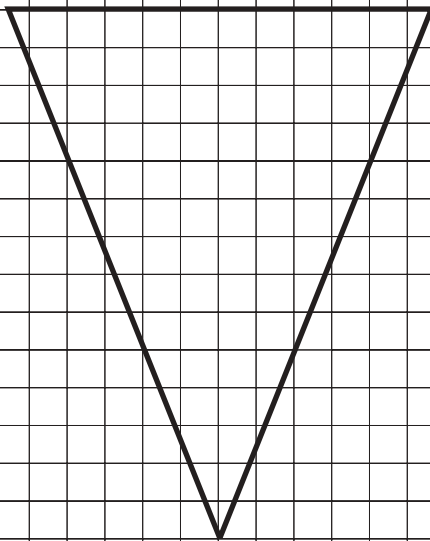
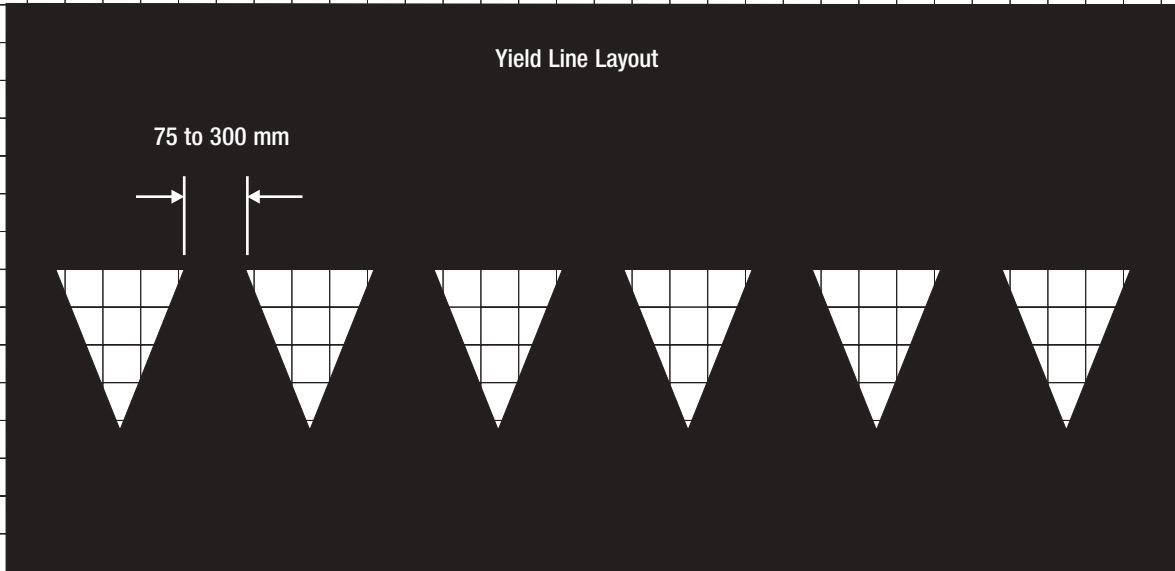

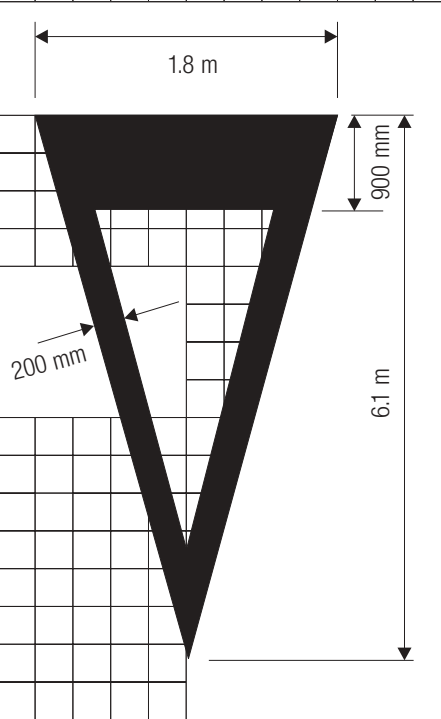

Yield Ahead Triangle

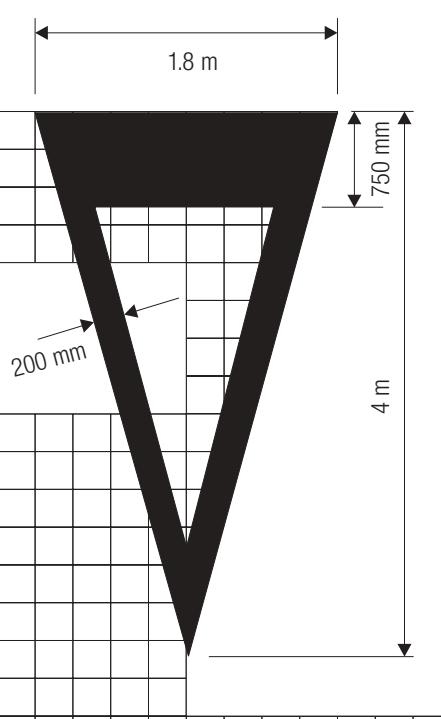

Speed Hump Markings

