

DEFINITION OF TREATMENT ZONES FOR EDGE DROP-OFF CONDITIONS

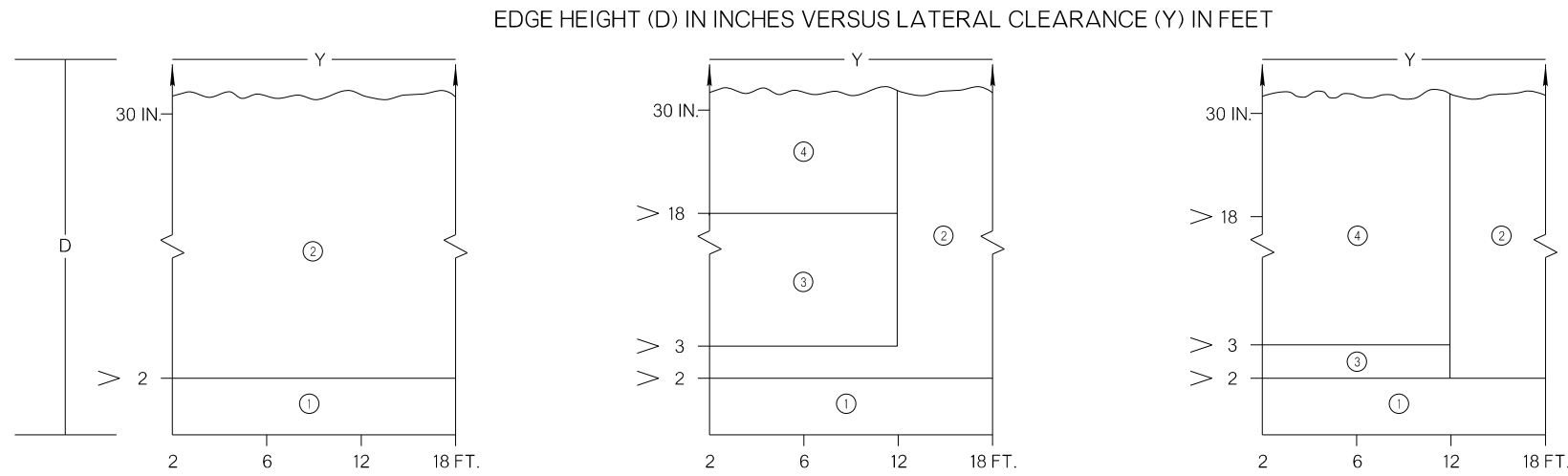

EDGE CONDITION I
S = 1:3 OR FLATTER

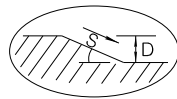

EDGE CONDITION II
S = 1:2.99 TO 1:1

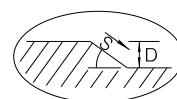

EDGE CONDITION III
S = STEEPER THAN 1:1

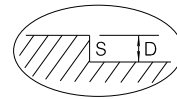

EDGE CONDITIONS I AND II: THE SLOPE MUST BE CONSTRUCTED WITH A COMPACTED MATERIAL CAPABLE OF SUPPORTING VEHICLES. LABOR AND MATERIAL SHALL BE INCLUDED IN OTHER ITEMS OF WORK.

EDGE CONDITION III: MILLING OR OVERLAY OPERATIONS THAT RESULT IN EDGE CONDITION III SHOULD NOT BE IN PLACE WITHOUT APPROPRIATE WARNING TREATMENTS, AND THESE CONDITIONS SHOULD NOT BE LEFT IN PLACE FOR EXTENDED PERIODS OF TIME.

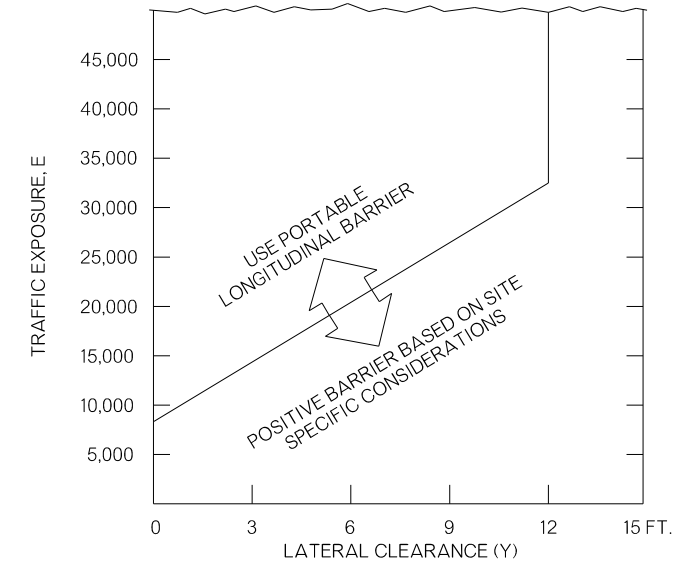

FIGURE-1: CONDITIONS INDICATING THE NEED FOR POSITIVE BARRIER

- $E = ADT \times T$
WHERE ADT IS THAT PORTION OF THE AVERAGE DAILY TRAFFIC VOLUME TRAVELING WITHIN 12 FEET (GENERALLY ONE ADJACENT LANE) OF THE EDGE DROP-OFF CONDITION; AND, T IS THE DURATION TIME IN YEARS OF THE DROP-OFF CONDITION.
- OTHER FACTORS, SUCH AS THE PRESENCE OF HEAVY MACHINERY, CONSTRUCTION WORKERS, OR THE MIX AND VOLUME OF TRAFFIC MAY MAKE THE NEED OF POSITIVE BARRIERS APPROPRIATE BY THE DESIGN ENGINEER, EVEN WHEN THE EDGE CONDITION ALONE MAY NOT JUSTIFY THE USE OF A BARRIER.
- AN APPROVED END TREATMENT SHALL BE PROVIDED FOR ANY POSITIVE BARRIER END LOCATED WITHIN APPLICABLE CONSTRUCTION CLEAR ZONE.

GENERAL NOTES

- THESE GUIDELINES APPLY TO CONSTRUCTION ZONE WORK WHERE CONTINUOUS PAVEMENT EDGES OR DROP-OFFS EXIST PARALLEL AND ADJACENT TO A LANE USED FOR TRAFFIC.
- THE FOLLOWING TYPES OF TREATMENT MAY BE USED:
 - WARNING DEVICES (SUCH AS SIGNS OR CHANNELIZING DEVICES), AND
 - PROTECTIVE BARRIERS (SUCH AS CONCRETE TRAFFIC BARRIERS).
- DISTANCE "X" IS TO BE THE MAXIMUM PRACTICAL UNDER JOB CONDITIONS. TWO FEET MINIMUM FOR HIGH SPEED CONDITIONS OR CONDITIONS WITH TRAVELING SPEEDS GREATER THAN AND EQUAL TO 45 MPH. DISTANCE "Y" IS THE LATERAL CLEARANCE FROM EDGE OF TRAVEL LANE TO EDGE OF DROP-OFF. DISTANCE "Z" DOES NOT HAVE A MINIMUM VALUE.
- EACH CONSTRUCTION ZONE DROP-OFF CONDITION SHOULD BE ANALYZED INDIVIDUALLY, TAKING INTO ACCOUNT OTHER VARIABLES, SUCH AS: TRAFFIC MIX, POSTED SPEED IN THE CONSTRUCTION ZONE, HORIZONTAL CURVATURE, AND THE PRACTICALITY OF THE TREATMENT TYPES.
- THE CONDITIONS FOR INDICATING THE USE OF POSITIVE OR PROTECTIVE BARRIERS ARE GIVEN BY FIGURE-1.

ZONE	TREATMENT TYPES GUIDELINES:
①	W8-11 "UNEVEN LANES" SIGNS.
②	W8-17 AND W8-17P "SHOULDER DROP-OFF" SIGNS PLUS APPROVED CHANNELIZING DEVICES.
③	W8-11 "UNEVEN LANES" AND W8-17 "SHOULDER DROP-OFF" SIGNS PLUS DRUMS. WHERE RESTRICTED SPACE PRECLUDES THE USE OF DRUMS, USE AN APPROVED CHANNELIZING DEVICE. AN EDGE FILL MAY BE PROVIDED TO CHANGE THE EDGE SLOPE TO THAT OF THE PREFERABLE EDGE CONDITION I.
④	SEE (FIGURE-1) WHERE POSITIVE BARRIER IS NOT INDICATED, THE TREATMENT SHOWN ABOVE FOR ZONE ③ MAY BE USED AFTER CONSIDERATION OF OTHER APPLICABLE FACTORS.

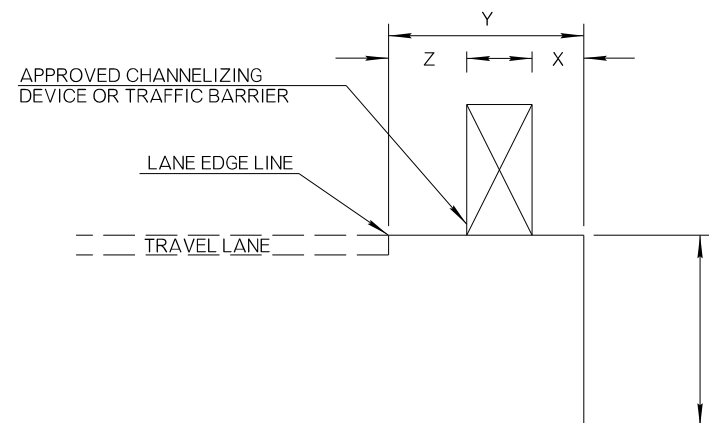

APPROVED BY ROADWAY ENGINEER: *[Signature]* DATE: 12/7/22
ROADWAY DESIGN DIVISION STANDARD

PAVEMENT DROP-OFF TREATMENTS



2019 SPECIFICATIONS