

SUGGESTED LENGTHS OF EACH SECTION OF SILT FENCE ARE AS FOLLOWS:

LONG. SLOPE	LENGTH
5%	60' MAX.
4%	75' MAX.
3%	100' MAX.
2%	150' MAX.
1%	300' MAX.

● LENGTH IS ONLY THE LONGITUDINAL LENGTH PARALLEL TO THE TOE OF SLOPE. LENGTH OF 'J-HOOK' IS DEPENDENT UPON FILL SLOPE.

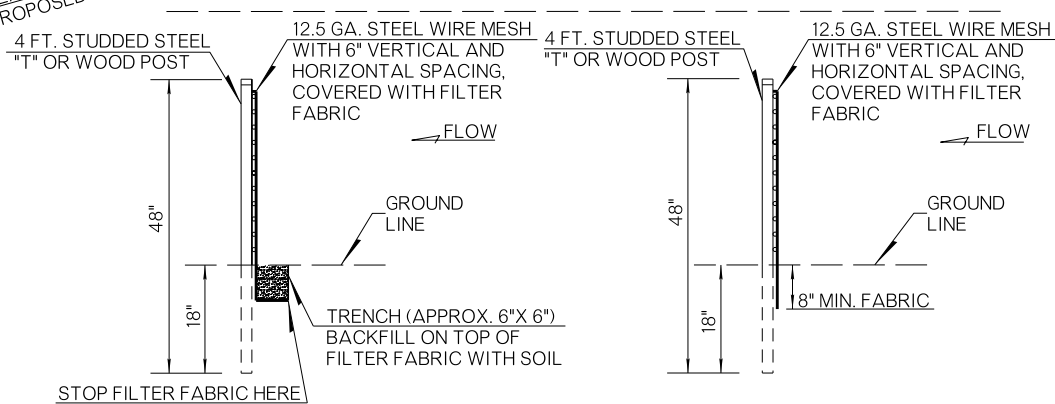
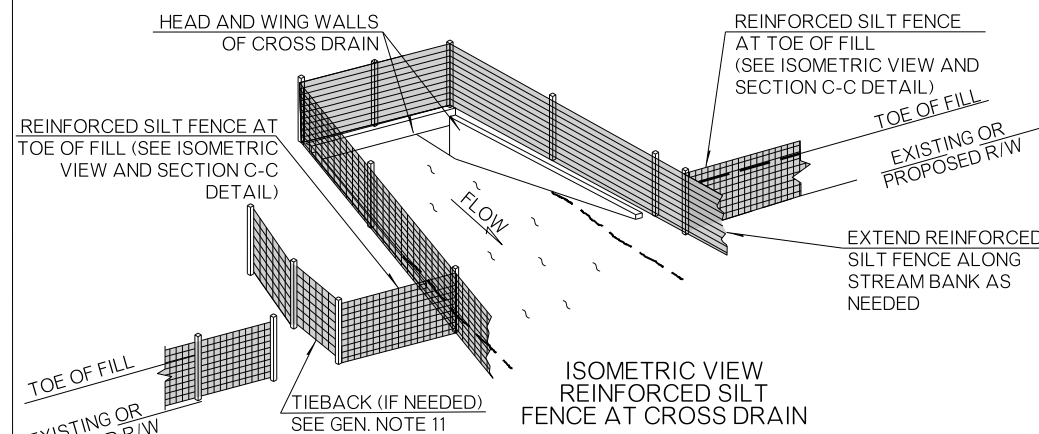
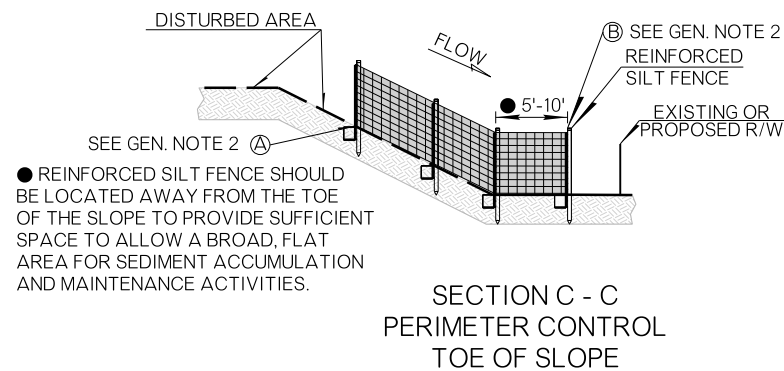
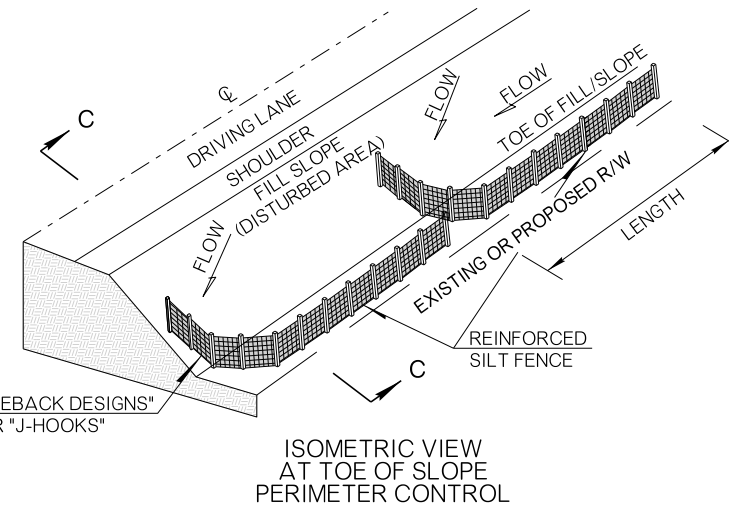

SIDE VIEW - METHOD I
TRENCHING INSTALLATION
(PREFERRED METHOD)

SIDE VIEW - METHOD II
MECHANICAL SLICING INSTALLATION

REINFORCED SILT FENCE
PERIMETER CONTROL APPLICATIONS

GENERAL NOTES

- ALL CONSTRUCTION AND MATERIAL REQUIREMENTS SHALL BE IN ACCORDANCE WITH THE 2019 ODOT STANDARD SPECIFICATIONS.
- AFTER THE REINFORCED SILT FENCE IS INSTALLED IN THE DITCH, IF THE TOP OF THE FILTER FABRIC (WEIR) AT POINT (B) IS HIGHER THAN THE BOTTOM OF THE FENCE AT POINT (A) (EDGES OF FENCE) THEN NO WEIR IS REQUIRED.
- REINFORCED SILT FENCE SHOULD BE PLACED WELL INSIDE RIGHT-OF-WAY AND ALONG EDGE OF CLEARING LIMITS. THIS WILL ALLOW ROOM FOR ADDITIONAL BEST MANAGEMENT PRACTICES SUCH AS VEGETATED BUFFERS.
- THE CONTRACTOR MAY ELECT TO USE EITHER INSTALLATION: METHOD I OR METHOD II.
- METHOD II INSTALLATION SHALL BE ACCOMPLISHED USING AN IMPLEMENT THAT IS MANUFACTURED FOR THE APPLICATION AND PROVIDES A CONFIGURATION MEETING THE REQUIREMENTS OF THE DETAIL.
- REINFORCED SILT FENCE SHALL BE A FILTER FABRIC SUPPORTED BETWEEN POSTS WITH A WIRE MESH BACKING. ATTACH THE FILTER FABRIC TO THE WIRE MESH USING 16 GA. GALVANIZED STEEL C-RING STAPLES OR OTHER SIMILAR ACCEPTABLE MEANS. PROVIDE FILTER FABRIC IN ACCORDANCE WITH AASHTO M 288 SPECIFICATION.
- WOOD POSTS SHALL BE OF SOUND QUALITY WOOD WITH A NOMINAL CROSS SECTIONAL AREA OF 1.5 X 1.5 INCHES. STEEL POSTS SHALL BE STANDARD T AND U SECTIONS WEIGHING NOT LESS THAN 1.33 POUNDS PER LINEAR FOOT OR OTHER STEEL POSTS HAVING EQUIVALENT STRENGTH AND BENDING RESISTANCE.
- FILTER FABRIC SHALL BE FURNISHED WITH A SUITABLE WRAPPING FOR PROTECTION AGAINST MOISTURE AND EXTENDED ULTRAVIOLET EXPOSURE PRIOR TO PLACEMENT. ROLLS SHALL BE STORED IN A MANNER WHICH PROTECTS THEM FROM THE ELEMENTS. IF STORED OUTDOORS, THEY SHALL BE ELEVATED AND PROTECTED WITH A WATERPROOF COVER.
- WIRE MESH BACKING SHALL BE MADE OF 12.5 GAUGE STEEL. THE VERTICAL AND HORIZONTAL SPACING OF THE WIRE SHALL BE 6 INCHES. ATTACH WIRE MESH TO POSTS BY MEANS OF 11 GA. ALUMINUM FENCE WIRE TIES AT 6.5 INCHES LONG, OR APPROVED SIMILAR.
- TIEBACK DESIGNS SHOULD BE INSTALLED SUCH THAT THE BOTTOM OF THE END OF THE SILT FENCE (WHERE THE J-HOOK IS INSTALLED ON THE SLOPE), OR POINT A, SHOULD BE AT A HIGHER ELEVATION THAN THE TOP OF THE SILT FENCE AT THE TOE OF THE FILL SLOPE, OR POINT B. SEE SECTION C-C FOR VISUAL.
- TIEBACK DESIGNS SHOULD ONLY BE USED WHEN THERE IS RUNOFF FLOW BOTH DOWN THE FILL SLOPE AND LONGITUDINALLY IN THE DIRECTION OF THE ROAD. MEASURE SILT FENCE IN PLACE, INCLUDING THE STRAIGHT SECTION AND THE 'J-HOOK' SECTION.
- PRICE BID FOR REINFORCED SILT FENCE SHALL INCLUDE COST OF ALL MATERIALS AND LABOR NECESSARY FOR CONSTRUCTION, MAINTENANCE AND REMOVAL, REGARDLESS OF APPLICATION.
- TEMPORARY (STANDARD) SILT FENCE MAY BE USED IN LIEU OF REINFORCED SILT FENCE IF APPROVED BY THE ENGINEER. TEMPORARY SILT FENCE IS TYPICALLY USED WHERE SHEET FLOW OCCURS. REINFORCED SILT FENCE IS USUALLY USED WHERE CONCENTRATION FLOW OCCURS.

BASIS OF PAYMENT		
ITEM NO.	ITEM	UNIT
221(B)	TEMPORARY SILT FENCE	LF
221(C)	REINFORCED SILT FENCE	LF

APPROVED BY ROADWAY ENGINEER: *RGS* DATE: 6/24/22
ROADWAY DESIGN DIVISION STANDARD



REINFORCED SILT FENCE
INSTALLATION AND APPLICATIONS

2019 SPECIFICATIONS

RSF	0
	R-6