

SECTION THRU CENTERLINE RCB CULVERT AND INLET

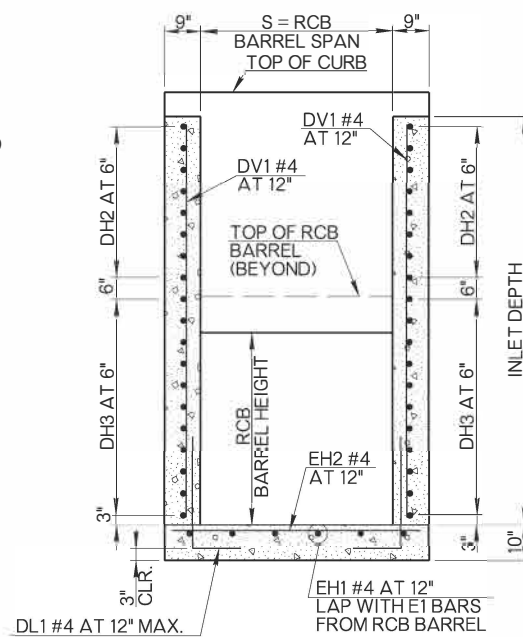

SECTION A - A THRU INLET

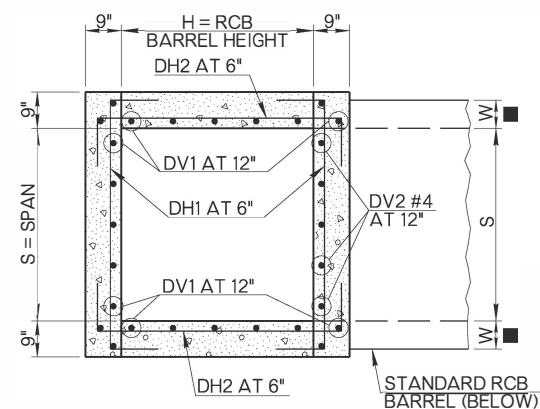

SECTION B-B THRU INLET

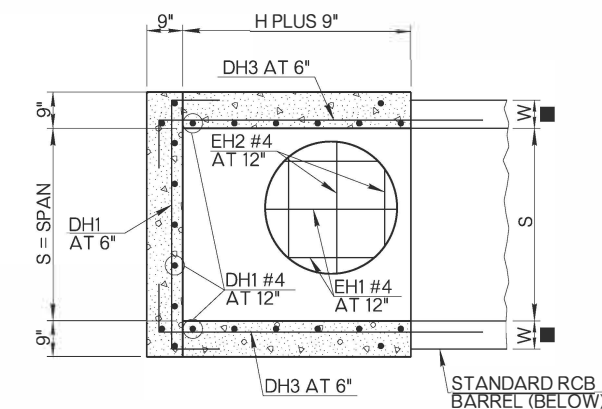

SECTION C-C THRU INLET AND CULVERT

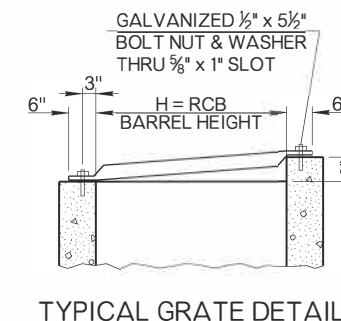
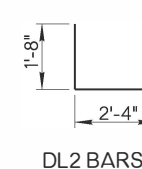
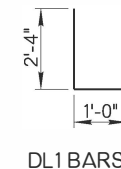
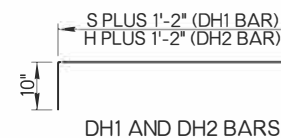

TYPICAL GRATE DETAIL

DIMENSIONS AND BAR LIST

DESIGN NO.	BARREL DIMENSIONS		STANDARD DEPTH	DH1 BARS (BENT)			DH2 BARS (BENT)			DH3 BARS (BENT)			DL1 #4 BARS (BENT)		DL2 #4 BARS (BENT)		DV1 #4 BARS		DV2 #4 BARS		DC #4 BARS		EH1 #4 BARS		EH2 #4 BARS	
	SPAN S	HEIGHT H		SIZE	NO.	LENGTH	SIZE	NO.	LENGTH	SIZE	NO.	LENGTH	NO.	LENGTH	NO.	LENGTH	NO.	LENGTH	NO.	LENGTH	NO.	LENGTH	NO.	LENGTH	NO.	LENGTH
1	3'	2'	3'-6"	#4	12	5'-10"	#4	8	4'-10"	#4	16	6'-0"	16	3'-4"	6	4'-0"	16	3'-4"	6		2	4'-2"	5	5'-1"	4	4'-2"
2	3'	3'	4'-6"	#4	14	5'-10"	#4	8	5'-10"	#4	20	7'-0"	18	3'-4"	6	4'-0"	18	4'-4"	6		2	4'-2"	5	6'-1"	5	4'-2"
3	4'	2'	3'-6"	#4	12	6'-10"	#4	8	4'-10"	#4	16	6'-0"	17	3'-4"	7	4'-0"	17	3'-4"	7		2	5'-2"	6	5'-1"	4	5'-2"
4	4'	3'	4'-6"	#5	14	6'-10"	#5	8	5'-10"	#5	20	7'-0"	19	3'-4"	7	4'-0"	19	4'-4"	7		2	5'-2"	6	6'-1"	5	5'-2"
5	4'	4'	5'-6"	#5	16	6'-10"	#5	8	6'-10"	#5	24	8'-0"	21	3'-4"	7	4'-0"	21	5'-4"	7		2	5'-2"	6	7'-1"	6	5'-2"
6	5'	2'	3'-6"	#5	12	7'-10"	#5	8	4'-10"	#5	16	6'-0"	18	3'-4"	8	4'-0"	18	3'-4"	8		2	6'-2"	7	5'-1"	4	6'-2"
7	5'	3'	4'-6"	#5	14	7'-10"	#5	8	5'-10"	#5	20	7'-0"	20	3'-4"	8	4'-0"	20	4'-4"	8		2	6'-2"	7	6'-1"	5	6'-2"
8	5'	4'	5'-6"	#5	16	7'-10"	#5	8	6'-10"	#5	24	8'-0"	22	3'-4"	8	4'-0"	22	5'-4"	8		2	6'-2"	7	7'-1"	6	6'-2"
9	5'	5'	6'-6"	#5	18	7'-10"	#5	8	7'-10"	#5	28	9'-0"	24	3'-4"	8	4'-0"	24	6'-4"	8		2	6'-2"	7	8'-1"	7	6'-2"
10	6'	3'	4'-6"	#5	14	8'-10"	#5	8	5'-10"	#5	20	7'-0"	21	3'-4"	9	4'-0"	21	4'-4"	9		2	7'-2"	8	6'-1"	5	7'-2"
11	6'	4'	5'-6"	#5	16	8'-10"	#5	8	6'-10"	#5	24	8'-0"	23	3'-4"	9	4'-0"	23	5'-4"	9		2	7'-2"	8	7'-1"	6	7'-2"
12	6'	5'	6'-6"	#5	18	8'-10"	#5	8	7'-10"	#5	28	9'-0"	25	3'-4"	9	4'-0"	25	6'-4"	9		2	7'-2"	8	8'-1"	7	7'-2"
13	6'	6'	7'-6"	#5	20	8'-10"	#5	8	8'-10"	#5	32	10'-0"	27	3'-4"	9	4'-0"	27	7'-4"	9		2	7'-2"	8	9'-1"	8	7'-2"

FOR INLETS WITH ADDITIONAL DEPTH ONLY, SEE REINFORCING FOR ADDITIONAL DEPTH NOTE.

GENERAL NOTES

- ALL CONSTRUCTION AND MATERIAL REQUIREMENTS SHALL BE IN ACCORDANCE WITH THE 2019 ODOT STANDARD SPECIFICATIONS.
- MAXIMUM DEPTH OF DROP INLETS SHALL BE THE HEIGHT OF THE RCB CULVERT PLUS 15'-0".
- ALL REINFORCING STEEL SHALL HAVE A 2" MINIMUM CLEAR COVER UNLESS OTHERWISE SHOWN.
- INLET TOP OPENING SHALL HAVE 3" x 7.58 LBS/FT STD. WEIGHT STEEL, GALVANIZED, SCHEDULE 40, PIPE SAFETY GRATES INSTALLED PERPENDICULAR TO THE DIRECTION OF TRAFFIC AT 12" MAX. CENTERS. COST OF PIPE SAFETY GRATES AND ALL HARDWARE NEEDED FOR INSTALLATION SHALL BE INCLUDED IN THE PRICE BID FOR THE INLET.
- PIPE GRATE ENDS SHALL BE HELD DOWN WITH 1/2" x 5/8" GALVANIZED BOLT, WASHER & NUT MEETING THE REQUIREMENTS OF ASTM F3125. BOLT THREADS, 1 3/4", SHALL REMAIN EXPOSED FOR INSTALLING GRATE.
- FOR 'T', 'U' AND 'W' DIMENSIONS, SEE BRIDGE STANDARD DRAWINGS.

▲ REINFORCING FOR ADDITIONAL DEPTH

- FOR INLET DEPTHS GREATER THAN STANDARD DEPTH:
- 2 ADDITIONAL DH1 BARS WILL BE REQUIRED FOR EVERY 6" OF ADDITIONAL DEPTH.
 - 2 ADDITIONAL DH2 BARS WILL BE REQUIRED FOR EVERY 6" OF ADDITIONAL DEPTH.
 - DV1 BARS WILL HAVE TO BE EXTENDED BY LENGTH EQUAL TO ADDITIONAL DEPTH OF INLET.
 - DV2 BARS WILL HAVE TO BE ADDED, WITH A LENGTH EQUAL TO ADD'L. DEPTH PLUS 1'-8".

QUANTITIES (FOR INFORMATION PURPOSES ONLY)

DESIGN NO.	CLASS AA CONCRETE		REINFORCING STEEL		PIPE GRATES	
	STANDARD DEPTH INLET	PER ADDITIONAL FT OF DEPTH	STANDARD DEPTH INLET	ADDITIONAL FOR EXTRA DEPTH INLETS	LENGTH OF PIPE	NUMBER OF GRATES
1	1.6 CY	0.37 CY	258 LBS	7 LBS+44 LBS/FT	3'-0 3/4"	2
2	2.2 CY	0.42 CY	328 LBS	7 LBS+48 LBS/FT	4'-0 1/2"	2
3	1.9 CY	0.42 CY	281 LBS	8 LBS+48 LBS/FT	3'-0 3/4"	3
4	2.6 CY	0.48 CY	460 LBS	8 LBS+71 LBS/FT	4'-0 1/2"	3
5	3.4 CY	0.53 CY	568 LBS	8 LBS+76 LBS/FT	5'-0 3/8"	3
6	2.1 CY	0.48 CY	389 LBS	9 LBS+71 LBS/FT	3'-0 3/4"	4
7	2.9 CY	0.53 CY	491 LBS	9 LBS+76 LBS/FT	4'-0 1/2"	4
8	3.7 CY	0.59 CY	603 LBS	9 LBS+82 LBS/FT	5'-0 3/8"	4
9	4.7 CY	0.64 CY	727 LBS	9 LBS+87 LBS/FT	6'-0 1/4"	4
10	3.2 CY	0.59 CY	522 LBS	10 LBS+82 LBS/FT	4'-0 1/2"	5
11	4.1 CY	0.64 CY	639 LBS	10 LBS+87 LBS/FT	5'-0 3/8"	5
12	5.1 CY	0.70 CY	766 LBS	10 LBS+93 LBS/FT	6'-0 1/4"	5
13	6.3 CY	0.75 CY	905 LBS	10 LBS+98 LBS/FT	7'-0 1/4"	5

BASIS OF PAYMENT

ITEM NO.	ITEM	UNIT
611(G)	INLET CDI RCB DES. ●	EA
611(H)	ADD'L. DEPTH IN INLET CDI RCB DES. ●	VF

● INLET DESIGN NUMBER SHALL BE SPECIFIED.

APPROVED BY ROADWAY ENGINEER: *[Signature]* DATE: 6/30/22

ROADWAY DESIGN DIVISION STANDARD

CAST-IN-PLACE CONCRETE DROP INLETS FOR R.C. BOXES (3' x 2' TO 6' x 6')



2019 SPECIFICATIONS