

C.E.T. TYPE	CULVERT TYPE				SIDE DRAIN		CROSS DRAIN		G DIMENSION
	REINF. CONC., STEEL OR ALUMINUM ROUND PIPE	REINF. CONC. ARCH PIPE	REINF. CONC. ELLIPTICAL PIPE (RISE x SPAN)	STEEL OR ALUMINUM ARCH PIPE	NO. OF GRATES	GRATE LENGTH L (SD)	NO. OF GRATES	GRATE LENGTH L (CD)	
AA4	18"			21" x 15"	2	5'-8"	NONE		12"
		22" x 13"	14" x 23"	24" x 18"	2	6'-6"	NONE		12"
	24"				2	6'-8"	NONE		12"
BB4		28" x 18"	19" x 30"	28" x 20"	2	7'-8"	2	10'-9"	12"
		36" x 22"	22" x 34"	35" x 24"	3	8'-6"	2	12'-0"	12"
			24" x 38"		3	9'-2"	2	12'-6"	15"
	30"				5	7'-10"	NONE		15"
CC4		43" x 26"		42" x 29"	3	10'-0"	2	13'-6"	15"
			29" x 45"	49" x 33"	3	10'-4"	2	14'-3"	15"
		51" x 31"			4	11'-8"	2	15'-3"	18"
			34" x 53"		4	12'-0"	2	15'-9"	18"
DD4	36"			57" x 38"	4	9'-8"	2	16'-6"	18"
	42"	58" x 36"	38" x 60"	64" x 43"	5	10'-4"	2	18'-9"	21"
		65" x 40"			5	14'-2"	4	18'-0"	21"
EE4	48"		43" x 68"	71" x 47"	6	11'-8"	2	20'-9"	24"
		73" x 45"			5	15'-0"	4	19'-0"	24"
			48" x 76"		6	16'-5"	4	20'-9"	26"

C.E.T. TYPE	LENGTH A	WIDTH BB	WIDTH BB	LENGTH C	HEIGHT H	HEIGHT K	CONC. CY	CONC. CY	STEEL LENGTH		
									H-BARS	H-BARS	S-BARS
AA4	10'-4"	8'-0"	9'-4"	5'-8"	21"	9"	2.45	2.90	7'-8"	9'-0"	12'-4"
BB4	12'-4"	9'-0"	11'-0"	6'-0"	22"	14"	2.95	3.75	8'-8"	10'-8"	15'-4"
CC4	15'-9"	10'-4"	14'-0"	7'-4"	26"	20"	4.45	5.75	10'-0"	13'-8"	19'-6"
DD4	19'-3"	12'-9"	16'-6"	8'-0"	28"	27"	6.00	8.00	12'-5"	16'-2"	21'-6"
EE4	20'-8"	14'-0"	18'-0"	8'-8"	30"	30"	7.35	9.30	13'-8"	17'-8"	23'-4"

(R) ROUND SHAPE CULVERT OPTIONS  
 (A) ARCH SHAPE CULVERT OPTIONS  
 (E) HORIZONTAL ELLIPSE SHAPE CULVERT OPTIONS

NOTE: FOR G DIMENSION, SEE TABLE A

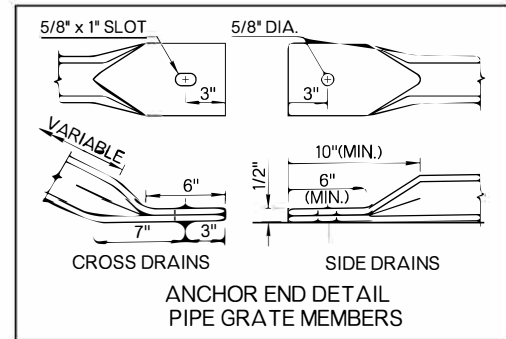

GENERAL NOTES

- ALL CONSTRUCTION AND MATERIAL REQUIREMENTS SHALL BE IN ACCORDANCE WITH THE 2019 ODOT STANDARD SPECIFICATIONS.
- QUANTITIES SHOWN IN TABLE B ARE FOR ONE END ONLY. CLASS A CONCRETE SHALL CONFORM TO THE MINIMUM REQUIREMENTS OF SECTION 509 OF THE ODOT SPECIFICATIONS.
- TYPES AA4 THROUGH EE4 END TREATMENTS, AS SHOWN IN TABLE B, MAY BE USED WITH ANY AASHTO DESIGNATED METAL, ALUMINUM AND CONCRETE PIPE SIZES, AS SHOWN IN TABLE A. END TREATMENT QUANTITIES ARE BASED ON METAL PIPE DIMENSIONS, NO PIPE WALL THICKNESS AND SMALLEST LISTED CULVERT ROUND OR ARCH WITHIN SAME TYPE.
- COAT THE FIELD OR SHOP CUT EDGES OF THE METAL PIPE CULVERT WITH TWO COATS OF COLD GALVANIZATION. COAT THE FIELD OR SHOP CUT EDGES OF THE CONCRETE PIPE CULVERT WITH CONCRETE OR AN APPROVED CORROSION INHIBITOR. IF THE PIPE CULVERT IS CUT AFTER THE CONSTRUCTION OF THE CULVERT END TREATMENT, THE CONTRACTOR SHALL ALLOW SUFFICIENT TIME FOR THE PROPER CURING OF THE CONCRETE. INCLUDE THE COST OF CUTTING AND COATING IN THE PRICE BID FOR THE METAL AND/OR CONCRETE PIPE CULVERT.
- ALL SIZES OF CULVERT PIPE WILL BE CUT ON 1 TO 4 SLOPE.
- PIPE FOR SAFETY GRATES SHALL BE 3" x 7.58 LBS./FT. STANDARD WEIGHT STEEL PIPE, SCHEDULE 40. IT SHALL BE FURNISHED GALVANIZED, PLAIN END AND SHALL MEET THE MINIMUM REQUIREMENTS OF ASTM A53 (HYDROSTATIC TESTS MAY BE WAIVED) OR ASTM F1083. COST OF GRATES TO BE INCLUDED IN PRICE BID FOR THE CULVERT END TREATMENT.
- ANY GALVANIZED AREA(S) OF METAL PIPE DISTRESSED DURING THE POST FABRICATION AND/OR HANDLING PROCESS SHALL BE COATED WITH AN APPROVED ZINC-RICH PAINT.
- REINFORCING STEEL AND PIPE GRATE GUIDES SHALL BE NO. 4 DEFORMED BARS. COST OF STEEL SHALL BE INCLUDED IN PRICE BID FOR THE CULVERT END TREATMENT.
- CRITERIA FOR USE OF PIPE SAFETY GRATE MEMBERS:
  - ALL SIDE DRAIN AND MULTIPLE PIPE INSTALLATIONS WITHIN THE CLEAR ZONE.
  - ALL CROSS DRAIN INSTALLATIONS WITH A CULVERT SPAN OF 30" OR LARGER WITHIN THE CLEAR ZONE.
  - ALL INSTALLATIONS OUTSIDE THE CLEAR ZONE WHERE HAZARD POTENTIAL IS HIGH BASED ON TRAFFIC DIRECTION, SPEED, VOLUME, AND SIZE OF CULVERT. NOTE: ANALYZE HYDRAULIC PERFORMANCE AT VARYING DEGREES OF CLOGGING AND APPLY RISK ASSESSMENT BEFORE USING GRATES.
- ANCHOR END OF PIPE GRATE MEMBERS SHALL BE HELD IN PLACE WITH A 1/2" x 5/16" GALVANIZED BOLT, NUT AND WASHER. THREADS, 1 3/4" (NOM.) SHALL REMAIN EXPOSED FOR INSTALLING GRATE, WASHER AND NUT. ALL BOLTS, NUTS AND WASHERS SHALL CONFORM TO ASTM A307 WITH COST TO BE INCLUDED IN THE PRICE BID FOR THE CULVERT END TREATMENT.
- FOR TOTAL QUANTITY OF EXTRA DEPTH TOE WALL, MULTIPLY WIDTH B (TABLE B) TIMES 0.0185 FOR EACH FOOT OF DEPTH OF TOE WALL REQUIRED. PAYMENT TO BE INCLUDED IN PRICE BID FOR THE CULVERT END TREATMENT.

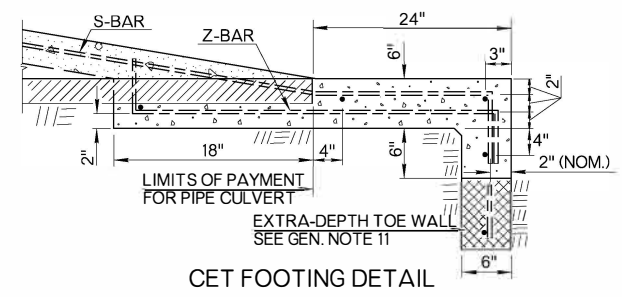
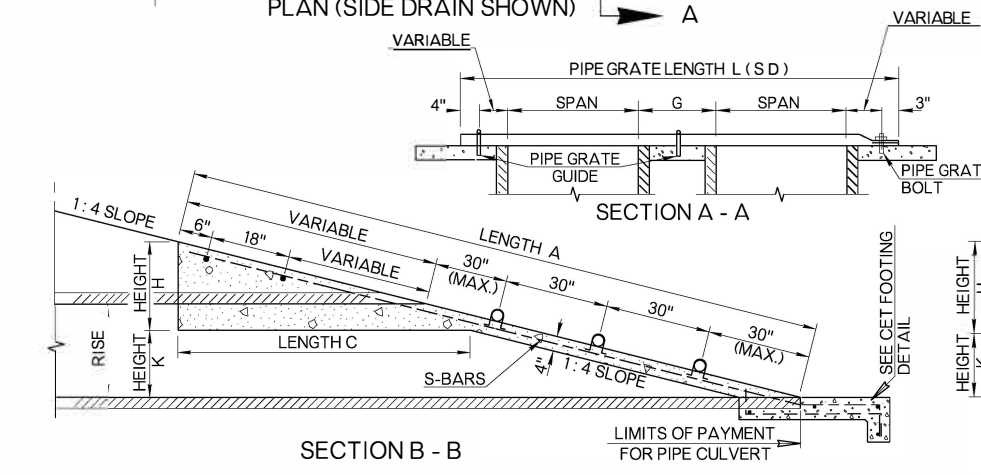
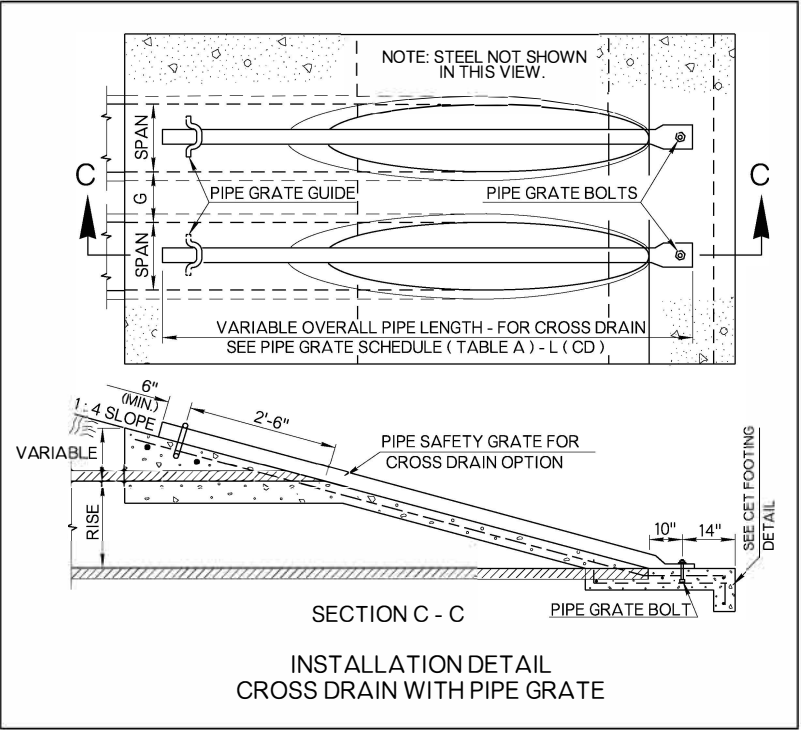
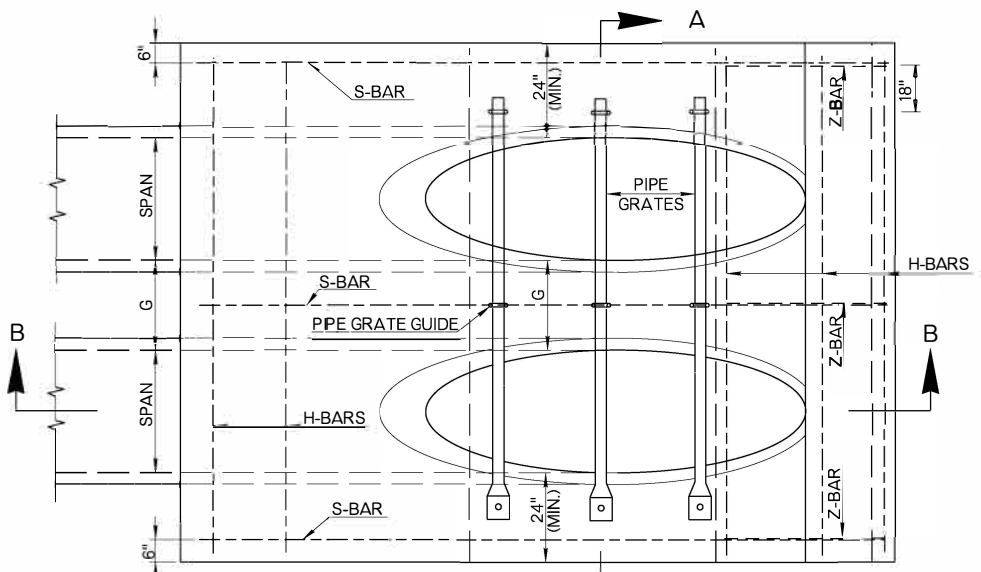

RS	- ROUND SIDE DRAIN
RC	- ROUND CROSS DRAIN
AS	- ARCH SIDE DRAIN
AC	- ARCH CROSS DRAIN
GR	- GRATED
NG	- NON-GRATED

PRECAST CULVERT END TREATMENTS OR OTHER ALTERNATIVE DESIGNS MAY BE USED IF APPROPRIATE DRAWINGS ARE SUBMITTED TO AND APPROVED BY THE ENGINEER.

ITEM NO.	ITEM	UNIT
613 (M)	CULVERT END TREATMENT	EA

- SPECIFY TYPE OF END TREATMENT (EXAMPLE: TYPE BB4 CULVERT END TREATMENT)
- CET ORIENTATION AND SAFETY GRATE REQUIREMENTS SHALL BE SPECIFIED ON THE SUMMARY OF DRAINAGE STRUCTURES. (SEE TYPICAL ABBREVIATIONS)

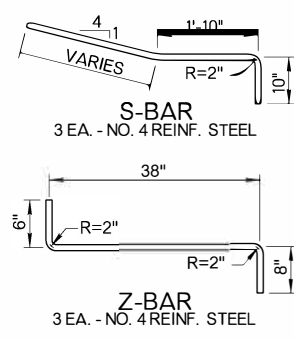
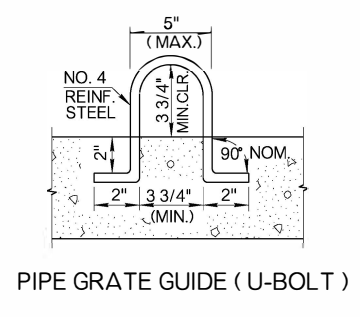
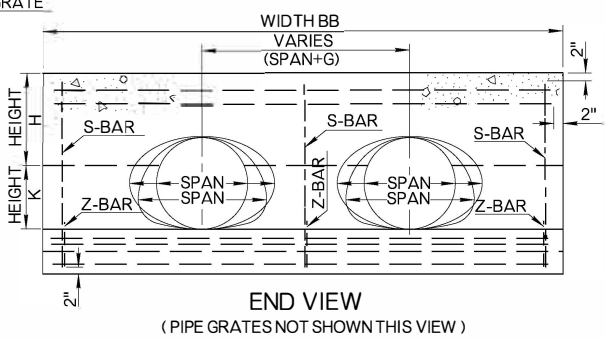

APPROVED BY ROADWAY ENGINEER: *[Signature]* DATE: 6/30/22

ROADWAY DESIGN DIVISION STANDARD  
 CULVERT END TREATMENT  
 DOUBLE PIPE INSTALLATION  
 1 TO 4 SAFETY SLOPE

