

OHD L-63
METHOD FOR USING
DYNAMIC CONE PENETROMETER (DCP) FOR UNDERCUT

1.0 **SCOPE**

- 1.1 This method covers the procedure for the determination of undercut boundaries through the strength of materials using a Dynamic Cone Penetrometer (DCP).
- 1.2 The DCP may be used for clay, silty, or sandy soils, granular soils, chemical modified soils, or as directed by the Department.
- 1.3 This OHDL may involve hazardous materials, operations, and equipment and may not address all of the safety problems associated with the use of the test method. The user of the OHDL is responsible for establishing appropriate safety and health practices and determining the applicability of regulatory limitations prior to use.

2.0 **REFERENCES**

- 2.1 ASTM Standards.

D 6951 Use of the Dynamic Cone Penetrometer in Shallow Pavement Applications

- 2.2 AASHTO Standards.

T 99 Moisture-Density Relations of Soils Using a 2.5-kg (5.5-lb) Rammer and a 305-mm (12-in.) Drop

- 3.0 **TERMINOLOGY** Definitions for terms and abbreviations shall be in accordance with the Department's Standard Specifications and the following:

- 3.1 Soil. Cohesive material with more than 35 % passing the No. 200 sieve. Clay, silty, and sandy soils are determined by the maximum dry density in accordance with AASHTO T 99 and are defined as follows:

3.1.1 Clay Soil. Soil with a maximum dry density of 114 lb/ft³ or less

3.1.2 Silty Soil. Soil with a maximum dry density greater than 114 lb/ft³ and less than or equal to 120 lb/ft³

3.1.3 Sandy Soil. Soil with a maximum dry density greater than 120 lb/ft³

3.2 Granular Soil. Soil that is non-cohesive with 35 % or less material passing the No. 200 sieve.

3.3 Chemical Modified Soil. Soil that has been modified with Portland cement, fly ash, lime, cement by-product, or a combination of these materials.

4.0 SIGNIFICANCE AND USE

4.1 This test method is for a modified use of the DCP to assess in situ strength of undisturbed soil, compacted soil, and granular material that may require undercut. The penetration rate of the DCP may be used to estimate and identify strata thickness, shear strength of strata, and other material characteristics.

5.0 APPARATUS

5.1 Dynamic Cone Penetrometer (Appendix A), with a 17.6 lbm steel drop hammer located between the handle and coupler assembly on a 0.625 in. Diameter steel rod. The steel rod is required to be a minimum of 24 in. in length and be threaded on both ends to allow the attachment of a cone on one end and an anvil on the other end. The distance from the bottom of the hammer to the coupler assembly is 22.6 in. On the bottom of the rod is a replaceable hard sharp conical tip with an included angle of 60° and a diameter at the base of 0.79 in. (Note 1). The rod shall have 0.5 in. graduations. A ruler may be used to indicate the required penetration of the DCP on the steel rod.

Note 1 – A disposable cone may be used in chemically modified or other hard soils to avoid damage to the equipment, which may be caused by driving the hammer upward to extract the cone from the soil.

6.0 PROCEDURE

6.1 Check the DCP components for deficiencies, replace any damaged part, and assemble the equipment as shown in Appendix A. All joints are required to be securely tightened.

6.2 Verify that the graduated rod (Note 2) and cone, or cone adaptor when using a disposable cone, are free of materials from the previous use.

Note 2 – The length of the graduated rod ranges from 24 in. to 40 in. The Department may select the length used based on a safe operating condition.

- 6.3 Scrape any loose material away from the site to be tested
- 6.4 Hold the DCP in a vertical or plumb position by the handle, and seat the cone such that the cone base is flush with the surface of the material to be tested. The DCP is held by the anvil. The initial reading is taken from the cone base. Do not record the number of blows required to seat the cone to the cone base.
- 6.5 Raise the hammer to the handle at the top of the upper rod without impacting the handle. Let the hammer drop freely on the anvil to drive the cone into the material (Note 3).

Note 3 – Large aggregates or rock strata may stop the penetration of the DCP. If after several blows relatively little penetration is achieved, the DCP is required to be moved 1 ft. away from the initial site and a new test conducted.

- 6.6 Count the number of blows for the required penetration of the DCP into the material. The penetration of the DCP depends on the material variability and resistance of the material. If the DCP does not penetrate the required depth of material after 25 blows, the test is discontinued and the material is considered to be in compliance with the strength requirements.
- 6.7 Remove the DCP rod from the material by forcefully raising the hammer to strike the bottom until the DCP is free from the material (Note 4).

Note 4 – Care is required to be taken to keep the DCP vertical or plumb during the extraction process to prevent bending of the rod. Do not rock the rod back and forth or in a circle to free the device from the material. The extraction of the rod in chemically modified soil is easier with a disposable cone.

Note 5 – When transporting the DCP, do not allow a horizontally-laying rod to support the weight of the hammer. The DCP should be disassembled, placed in the case, or placed horizontally with the hammer resting next to the anvil. Both the upper and lower rod will bend if they are required to support the weight of the hammer.

7.0 ACCEPTANCE CRITERIA

- 7.1 Clay Soil. For clay soil, the strength of the soil is measured after completion of the compaction of each 6 in. of the soil. The number of blows of the DCP is measured for a penetration of 6 in. into the soil.

- 7.2 Silty Soil. For silty soil, the strength of the soil is measured after completion of compaction for each 12 in. of the soil. The number of blows of the DCP is measured for a penetration of 12 in. into the soil.
 - 7.3 Sandy Soil. For sandy soil, the strength of the soil is measured after completion of compaction for each 12 in. of the soil. The number of blows of the DCP is measured for a penetration of 12 in. into the soil.
 - 7.4 Chemically Modified Soils. For chemically modified soils, the strength of the soil is measured after completion of the compaction of each type of chemical modification.
 - 7.4.1 For an 8 in. lift, the number of blows of the DCP is measured for a penetration of 8 in. into the soil.
 - 7.4.2 For a 14 in. lift, the number of blows of the DCP is measured initially for a penetration of the top 6 in. of the lift. A separate number of blows of the DCP is measured for a penetration into the bottom 8 in. of the lift.
 - 7.5 Granular Materials. For granular materials, the strength of the material is measured after completion of compaction for each 12 in. of the material. The number of blows of the DCP is measured for a penetration of 12 in. into the granular material.
 - 7.6 For acceptance of undercut boundaries, the DCP should be at maximum 1-3 inches per blow to define a suitable bottom to begin placing fill dependent upon soil type.
- 8.0 **REPORT** Report the number of blows to obtain the required penetration of the DCP.

FIG. 1 Schematic of DCP Device

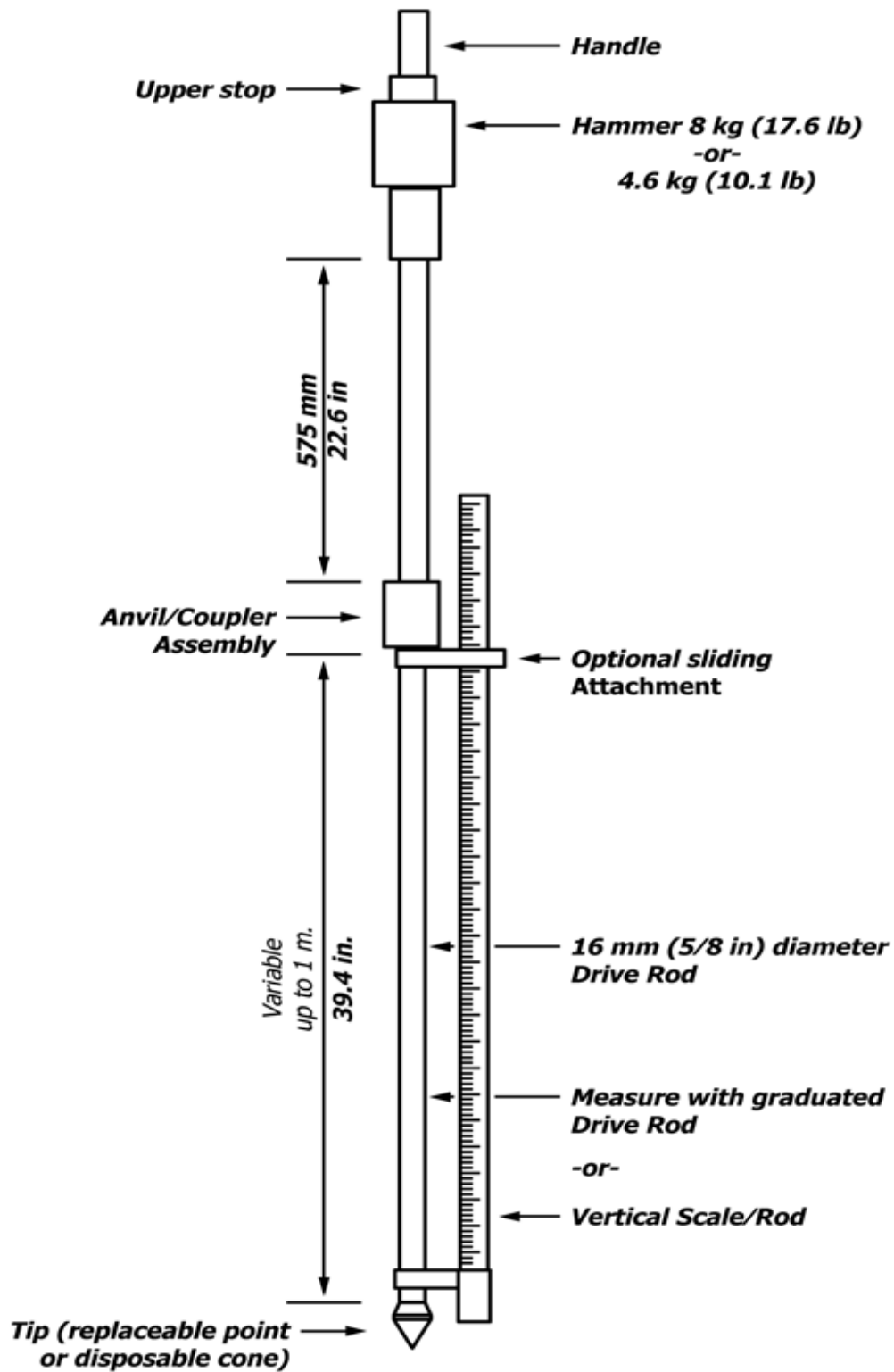

FIG. 2 Replaceable Point Tip

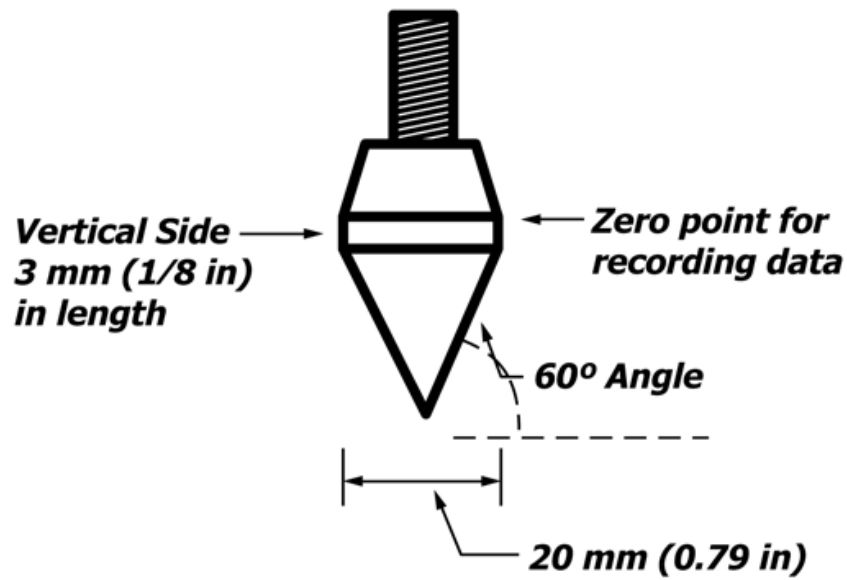

FIG. 3 Disposable Cone Tip

