



Sandra Richardson

Noble County Clerk
300 Courthouse Drive, #11
Perry, OK 73077

580-336-2141
County Clerk's Office

580-336-2596
Purchasing Office

580-336-2481
Fax

January 23, 2017

TO WHOM IT MAY CONCERN:

Bids will be received until 4:00 p.m. on February 10, 2017, at the Noble County Purchasing Office, located on the second floor of the Noble County Courthouse, located in the center of the square of Perry, Oklahoma, or may be mailed to the Noble County Purchasing Office, 300 Courthouse Drive # 11, Perry, Oklahoma 73077.

Said bids will be publicly opened and considered by the Board of Noble County Commissioners in the Commissioners' Office located in the Noble County Courthouse, Perry, Oklahoma, on February 13, 2017, with the right being reserved to reject any and all bids.

The following criteria should be met when submitting a bid:

1. The bid shall be made on the enclosed "Invitation to Bid."
2. An Affidavit of Non-Collusion must accompany all bids.
3. All prices quoted shall be F.O.B. the Noble County Requesting Agency unless otherwise state.
4. Place your bid in a sealed envelope inside the envelope to be mailed, clearly marking both envelopes:
"Sealed Bid #13-2016-2017 to be opened February 13, 2017." This will ensure that the bid will not be voided due to accidental opening.
5. Pre-Bid Meeting (Non-Mandatory) will be held on February 2, 2017 at 10:00 a.m. at the Noble County District #1 Barn.

Thank you for your cooperation and participation in this bidding procedure. If you should have any questions or concerns, please feel free to contact the Noble County Purchasing Office at 580-336-2596.

Respectfully,

A handwritten signature in blue ink that reads "Sharlott Beier".

Sharlott Beier
Deputy Noble County Clerk

NOBLE COUNTY, OKLAHOMA
COUNTY PURCHASING OFFICE
NOBLE COUNTY COURTHOUSE
PERRY, OKLAHOMA
580-336-2596

INVITATION TO BID

*Please review terms and conditions on reverse side relating to submission of this bid.
Notarized Affidavit completion and signature required on reverse side.*

Bid No.: 13-2016-2017
Date Issued: January 23, 2017
Bid Closing Date and Hour: February 10, 2017, at 4:00 p.m.
Terms: All bids shall be F.O.B. Noble County unless otherwise specified.
Required Delivery Date: As Per Attached Specifications

Unit of Item	Quantity	Issue	Description	Unit Price	Total
-----------------	----------	-------	-------------	---------------	-------

Bid #13-2016-2017
Bridge Materials & Steel Package
For Noble County District #1

Noble County will address A.D.A. needs upon proper notification.
Noble County reserves the right to award this bid in part or in whole.
Noble County reserves the right to reject any and all bids.
The Board of County Commissioners reserves the right to waive minor technicalities under these specifications.

Vendor's F.E.I. Number or Social Security Number: _____

TERMS AND CONDITIONS

1. Sealed bids will be opened in the Commissioner's Conference Room, Noble County Courthouse, Perry, OK, at the time and date shown on the invitation to bid form.
2. **Late bids will not be considered.** Bids must be received in a sealed envelope (one per envelope) with bid number and closing date written on the outside of envelope.
3. Unit prices will be guaranteed correct by the bidder
4. Firm prices will be F.O.B. destination.
5. Purchases by Noble County, Oklahoma, are not subject to state and/or federal taxes.
6. This bid is submitted as a legal offer, and any bid when accepted by the County constitutes a firm contract.
7. Oklahoma laws require each bidder submitting a bid to a county for goods or services to furnish a notarized sworn statement of non-collusion. A form is supplied below.
8. **Bids will be firm until March 13, 2017.**

AFFIDAVIT: I, the undersigned, of lawful age, being first duly sworn on oath say that he/she is the agent authorized by the bidder to submit the above bid. Affiant further states that the bidder has not been a party to any collusion among bidders in restraint of freedom of competition by agreement to bid at a fixed price or to refrain from bidding; or with any state official or employee as to quantity, quality or price in the prospective contract or any other terms of said prospective contract; or in any discussions between bidders and any state official concerning exchange of money or other thing of value for special consideration in the letting of a contract; that the bidder/contractor has not paid, given or donated or agreed to pay, give or donate to any officer or employee of the State of Oklahoma (or other entity) any money or other thing of value, either directly or indirectly in the procuring of the award of a contract pursuant to this bid.

Company Name

Toll Free Business #

Mailing/Remittance Address

City

State

Zip Code

E-mail Address(if available)

Signature

Title

Subscribed and sworn before me this _____ day of _____, 20____.

My Commission Expires:

Notary Public

NOTE: Other terms and conditions can be added at the discretion of the Noble County Officers.

NONCOLLUSION AFFIDAVIT

State of Oklahoma

County of _____

_____, of lawful age, being first duly sworn, on oath says that (s)he is the agent authorized by the bidder to submit the attached bid. Affiant further states that the bidder has not been a party to any collusion among bidders in restraint of freedom of competition by agreement to bid at a fixed price or to refrain from bidding; or with any state official or employee as to quantity, quality or price in the prospective contract, or any other terms of said prospective contract; or in any discussions between bidders and any state official concerning exchange of money or other thing of value for special consideration in the letting of a contract.

Subscribed and sworn to before me this _____ day of _____ 20____

Notary Public

My Commission Expires:

NOTE: This form to be submitted with the BID

Invitation To Bid Bridge Material & Steel Package

Noble County Commissioners are taking bids for bridge materials and steel for Bridge Replacement of One (1) Bridge on Yearling Road ¼ mile West of County Road 170, Structure #52E0350N3260007, Circle #15, in Noble County, Oklahoma.

Materials:

See Attached

CONTRACT DOCUMENTS
AND
PLANS AND SPECIFICATIONS

for

Noble County
Bridge Project

CN 15

52E0350N3260007

Prepared for

Noble County,

January 2017

TABLE OF CONTENTS

Invitation to Bid

Proposal

Non-Collusion Affidavit

Business Relationships Affidavit

Contract

Maintenance Bond

Performance Bond

Statutory Bond

Notice to Proceed

Invoice Affidavit

* Division I - General Provisions

* Technical Specifications

* See ODOT 2009 Standard Specifications for Highway Construction

Noble County, Oklahoma
 COUNTY PURCHASING OFFICE
 Noble County Courthouse
 Perry, OK 73077

INVITATION TO BID

PLEASE REVIEW TERMS AND CONDITIONS ON REVERSE SIDE RELATING TO SUBMISSION OF THIS BID.					DATE ISSUED
Notarized Affidavit completions and signature required on reverse side.					Page 1 of <u> 2 </u>
BID NUMBER			BID CLOSING DATE AND HOUR February 10 th , 2017 at 4:00 p.m.		REQUIRED DELIVERY DATE _____ Days after award of Purchase Order
TERMS: Bidding documents shall be obtained from the Noble County Courthouse. Bids will be opened during the commissioners meeting on Monday, February 13 st , 2017 at 9:00 a.m.					DATE OF DELIVERY:
Item	Quantity	Unit of Issue	Description	Unit Price	Total
			Bridge CN 15 52E0350N3260007 Pre-Bid Meeting Non-Mandatory Date: February 2nd, 2017 Time: 10:00 a.m. Location: Noble County District #1 Barn		

TERMS AND CONDITIONS

1. Sealed bids will be opened in the Commissioners Conference Room, Noble County Courthouse, 300 Courthouse Drive #1, Perry, OK 73077 at the time and date shown on the invitation to bid form.
2. Late bids will not be considered. Bids must be received in sealed envelopes (one to an envelope) with bid number and closing date written on the outside of each envelope.
3. Unit prices will be guaranteed correct by the bidder.
4. Firm prices will be F.O.B. destination.
5. Purchases by Noble County, Oklahoma are not subject to state or federal taxes.
6. This bid is submitted as a legal offer and any bid when accepted by the County constitutes a firm contract.
7. Oklahoma laws require each bidder submitting a bid to a county for goods or services to furnish a notarized sworn statement of non-collusion. A form is supplied below.
8. Bids will be firm until _____ .
(Date)

AFFIDAVIT: I, the undersigned, of lawful age, being first duly sworn on oath say that he (she) is the agent authorized by the bidder to submit the above bid. Affiant further states that the bidder has not been a party to any collusion among bidders in restraint of freedom of competition by agreement to bid at a fixed price or to refrain from bidding; or with any state official or employee as to quantity; quality or price in the prospective contract or any other terms of said prospective contract; or in any discussions between bidders and any state official concerning exchange of money or other thing of value for special consideration in the letting of a contract; that the bidder/contractor has not paid, given or donated or agreed to pay, give or donate to any officer or employee of the State of Oklahoma (or other entity) any money or other thing of value, either directly or indirectly in the procuring of the award of a contract pursuant to this bid.

Subscribed and sworn before this _____ day
of _____, 20_____.

(SEAL)

Firm: _____

My commission expires: _____

Signed by: _____ Title: _____
(Manual Signature of Undersigned)

NOTARY PUBLIC (CLERK OR JUDGE)

Address: _____ Phone: _____

City: _____ State: _____

Zip: _____

PROPOSAL

TO: Noble County Commissioners
Noble County, Oklahoma

Gentlemen:

Pursuant to the notice inviting proposals, the undersigned bidder herewith submits his proposal.

He declares he has carefully examined the Plans, Specifications and forms of Contract and bonds as set forth in the proceedings for:

**Noble County
Bridge Project
CN 15
52E0350N3260007**

and that he has reached a full understanding of everything required on said Plans and Specifications, and that he has informed himself as to the kind and quantities of various materials to be furnished and/or the nature and location of the work to be done, and all other matters affecting the work.

The undersigned bidder proposes and agrees that if his proposal is accepted, to enter into contract with the County, on forms prescribed, with approved sureties, within seven (7) days, after notice of award to execute the Contract, and to furnish to the County a satisfactory Performance and Statutory Bond in the sum of 100% of the contract price, guaranteeing the faithful performance of the work and payment of bills.

To do any extra work not covered by the following schedule of prices or stipulated lump sum price which may be ordered by the Engineer and to accept as full compensation therefor such prices as may be agreed upon in writing by the Engineer and the Contractor in accordance with Section 108.04 of the General Provisions.

It is further agreed that the Contractor shall begin the work on **July 1, 2017** as indicated in the Notice to Proceed and to prosecute said work in such a manner as to complete all work contracted for by **September 1, 2017**. The Notice to Proceed shall become effective on July 1, 2017.

The Contractor shall take out and maintain public liability insurance in accordance with Section 106.25 of the General Provisions of the Specifications. A copy of said Specifications is now on file in the Office of the County Clerk.

Upon completion of the Contract, the Contractor shall furnish to the County a satisfactory Maintenance Bond in the amount of 100% of the final contract price, guaranteeing the maintenance of the work for a period of **ONE** (1) year after acceptance by the County.

Accompanying this proposal is a proposal guaranty for 5% of the total bid, payable to Noble County, which is to be forfeited, as liquidated damages, if, in the event that this proposal is accepted, the undersigned shall fail to execute the contract and furnish satisfactory contract bond under the conditions and within the time specified in this proposal. Otherwise said proposal guaranty is to be returned to the undersigned.

PROPOSAL
Noble County
Bridge Project
CN 15
52E0350N3260007

CONSTRUCTION PAY QUANTITIES						
Item	Description	Units	Quantity	Unit Price	Total Price	Bid Price for Material over Planned Quantity
1	Bridge Construction Labor	L. Sum	1.00			N/A
2	Class AA Concrete & Finishing	C.Y.	50.00			

TOTAL CONSTRUCTION BID _____

MATERIAL PAY QUANTITIES						
Item	Description	Units	Quantity	Unit Price	Total Price	Bid Price for Material over Planned Quantity
1	HP 10" X 42# (12-40' PCS), Piles	L.F.	480.00			
2	HP 12" X 53# (12-40' PCS), Piles	L.F.	480.00			
3	HP 12" X 53# (2-32' PCS), Caps	L.F.	64.00			
4	5 1/2" X 1/2" FLAT, Bent Cap Stiffener	L.F.	40.00			
5	8" X 3/8" FLAT, Deck Sides	L.F.	120.00			
6	C8" X 11.5# CHANNEL, Backwall Bracing	L.F.	500.00			
7	C10" X 15 1/3# CHANNEL, Deck Ends	L.F.	60.00			
8	C12" X 25# CHANNEL, Wing Cap	L.F.	75.00			
9	3" X 3" X 1/4" ANGLE	L.F.	800.00			
10	5" X 3" X 1/4" ANGLE	L.F.	140.00			
11	REBAR, #4	L.F.	2020.00			
12	REBAR, #5	L.F.	9140.00			
13	SLAB BOLSTERS, 1"	E.A.	96.00			

14	STEEL REBAR CHAIRS, 4"	E.A.	144			
15	REBAR TIES, 6"	ROLL	1.00			
16	WELD STUDS, 3/4" X 4"	E.A.	288.00			
17	WELD STUDS, 5/8" X 6"	E.A.	180.00			
18	TUBULAR RAIL	L.F.	120.00			
19	W-BEAM END SECTION (FLARED)	E.A.	4.00			
20	BACKWALL SHEETING, INTERLOCKING GALV. 10 GA.	S.F.	3189.00			
21	GALV. DECK FORM	S.F.	1800.00			
22	GUARDRAIL POST, W 6" X 20#,	L.F.	160.00			

TOTAL MATERIAL BID _____

PROPOSAL

A Bidder's Bond, Certified or Cashier's Check is enclosed in the amount of \$ _____, as required.

STATE OF _____)
) SS:
COUNTY OF _____)

_____ of lawful age, being first duly sworn, upon his oath, deposes and says, that he executed the accompanying bid on behalf of the bidder named therein for the construction of the above improvement in NOBLE COUNTY, OKLAHOMA, that he had lawful authority so to do and that the bidder has not been a party to any collusion among bidders in restraint of freedom of competition by agreement to bid at a fixed price or to refrain from bidding; or with any State or County official or employee as to quantity, quality, or price in the prospective contract, or any other terms of said prospective contract; or in any discussions between bidders and any State or County officials concerning exchange of money or other thing of value for special consideration in the letting of a contract; said bidder has neither directly nor indirectly entered into any agreement, express or implied, with any bidder or bidders, having for its object the controlling of the price or amount of such bid or bids, the limiting of the bids or bidders, the parceling or farming out to any bidder or bidders, or other persons of any part of the contract or any part of the profits thereof and that he has not and will not divulge the sealed bid on such public improvement to any person whatsoever, except those having a partnership or other financial interest with him in said bid or bids, until after the sealed bid or bids are opened.

If partnership, give name and address of each partner

By: _____

Address: _____

Incorporated under the laws of the State of: _____

Subscribed and sworn to before me this _____ day of _____, 20_____.

Notary Public

(SEAL)

My Commission Expires: _____

NON-COLLUSION AFFIDAVIT

To Accompany Contractor's Bid

STATE OF _____)
) ss:
COUNTY OF _____)

_____ (Contractor's Authorized Agent), of lawful age, being first duly sworn upon his/her oath, states:

1. I am the duly authorized agent of _____ (Bidder's Company Name), the bidder submitting the attached competitive bid (the "bid"), for the purpose of certifying the facts pertaining to the existence or nonexistence of collusion among bidders or between bidders and municipal officials or employees, as well as facts pertaining to the giving or offering of things of value to government personnel in return for special consideration in the award of any contract associated with the bid attached to this document;
2. I am fully aware of the facts and circumstances surrounding the making of the bid and have been personally and directly involved in the proceedings leading to the submission of such bid;
3. Neither the bidder nor anyone subject to the bidder's direction or control has been a party to: Any collusion among bidders to restrain the freedom of competition by agreement to bid at a fixed price or to refrain from bidding; Any collusion with any county official or employee as to quantity, quality, or price in the bid or contemplated contract, or as to any other terms of such bid or contemplated contract; nor any discussions between bidders and any county official or employee concerning the exchange of money or other thing of value for special consideration in the award of the contemplated contract.

Further, Affiant saith not.

Signature of Authorized Agent

Title (printed)

Subscribed and sworn to before me this _____ day of _____, 20____.

(SEAL)

My commission expires:

Notary Public

BUSINESS RELATIONSHIP AFFIDAVIT

To Accompany Contractor's Bid

STATE OF _____)

) ss:

COUNTY OF _____)

_____ (Contractor's Authorized Agent), of lawful age, being first duly sworn upon his/her oath, states:

1. I am the duly authorized agent of _____ (Bidder's Company Name), the bidder submitting the attached competitive bid (the "bid").

2. My position in the above named company is _____.

3. Affiant further states the nature of any partnership, joint venture, or other business relationship presently in effect, or which existed within one (1) year prior to the date of this Affidavit, with the architect, engineer, or other party to the project is as follows:

(if none, so state)

4. Affiant further states that any such business relationship presently in effect or which existed within one (1) year prior to the date of this Affidavit between any official or director of the architectural or engineering firm or any other party to the project is as follows:

(if none, so state)

5. Affiant further states that the names of all persons who have any such business relationship and the positions they hold with their respective companies or firms are as follows:

(if none, so state)

Further, Affiant saith not.

Signature of Authorized Agent

Title (printed)

Subscribed and sworn to before me this _____ day of _____, 20____.

(SEAL)
My commission expires:

Notary Public

CONSTRUCTION CONTRACT

This Contract is made and entered into this _____ day of _____, 20____, by and between Noble County, Oklahoma hereinafter called "County and _____, a(n) _____, hereinafter called "Contractor."

WITNESSETH

WHEREAS, in accordance with the state law and the Public Competitive Bidding act of 1974, 61 Okla. Stat. §§ 101 et seq. (hereinafter collectively referred to as "state law"), the County has caused to be prepared certain plans, specifications, and other bidding documents (the "Bidding Documents") for the work hereinafter described; and,

WHEREAS, in accordance with state law, the County has approved and adopted all of said Bidding Documents and has caused an Invitation to Bid to be given and advertised and has received sealed bids for the furnishing of all labor and materials for:

**Noble County
Bridge Project
CN 15
52E0350N3260007**

as outlined and set out in the Bidding Documents and in accordance with the terms and provisions of this Contract; and,

WHEREAS, Contractor, in response to said Invitation to Bid, has submitted to the County, in the manner and at the time specified, a sealed bid in accordance with the terms of the Bidding Documents; and,

WHEREAS, the County, in the manner provided by state law, has publicly opened, examined and canvassed the bids submitted and has determined and declared the above-named Contractor to be the lowest responsible bidder on the above described project; and,

WHEREAS, the County has duly awarded this Contract to said Contractor, for the sum named in the bid, to-wit:

Dollars and Cents spelled out here (\$.).

NOW THEREFORE, in consideration of the mutual promises, covenants, and conditions herein stated and in consideration of the mutual benefits, which will accrue to the parties, the sufficiency of which is acknowledged by the parties, the parties agree as follows:

- 1. Incorporation of Bidding Documents. This Contract hereby incorporates, as if fully set out herein, the Plans, Specifications, General Provisions, Special Provisions, Contractor's Proposal and any and all Addendums issued. All of these documents have been provided to and/or by the Contractor and are on file in the Office of the County Clerk. Hereinafter, these documents shall be collectively referred to as "Bidding Documents."

2. Engagement of Contractor. The County hereby engages Contractor to perform certain construction services for the benefit of the County. Contractor accepts such engagement pursuant to the terms and conditions set forth herein.

3. Scope of Engagement. Contractor shall, in a good and first-class, workmanlike manner, at its own cost and expense, furnish all labor, materials, tools and equipment required to perform and complete said work in strict accordance with the Bidding Documents, with the following additions and/or exceptions: (if none, so state.)

(NONE)

4. Payments to Contractor. The County shall make payments to the Contractor in the following manner:

a. On or about the first (1st) day of each month, the Engineer, or other appropriate person, will make accurate estimates of the value, based on contract prices, of the work done and materials incorporated in the work and of materials suitably stored at the site thereof during the preceding calendar month. The Contractor shall furnish to the Engineer such detailed information as he may request to aid him as a guide in the preparation of the monthly estimates. Ninety-five percent (95%) of such estimated sum shall be paid to the Contractor within five (5) days after the first regularly scheduled meeting of the County of the following month.

b. On completion of the work, but prior to the acceptance thereof by the County, it shall be the duty of the Engineer for the County, or other appropriate person, to determine that said work has been completely and fully performed in accordance with this Contract and all incorporated documents; and upon making such determination, said official shall make his final certification to the County.

c. The Contractor shall furnish proof that all claims and obligations incurred by him in connection with the performance of said work have been fully paid and settled; said information shall be in the form of an affidavit, which shall bear the approval of the surety on the contract bonds, for payment of the final estimate to the Contractor; thereupon, the final estimate (including retainage, but less any liquidated damages), will be approved and paid, within five (5) days after the first regularly scheduled meeting of the County of the following month.

5. Bargaining. The County and the Contractor have had the opportunity to seek independent legal counsel before entering into this Contract. The language of this Contract shall be construed simply, according to its fair meaning, and not strictly for or against either party.

6. Third Party Beneficiaries. Nothing in this Contract, expressed or implied, is intended to confer upon any person other than the parties hereto and their respective assigns, any rights or remedies under or by reason of this Contract, except as provided expressly herein.

7. Notices. Whenever a notice is required to be given in writing and under the terms of this Contract, or any extension hereunder, such notice shall either be hand-delivered or mailed by certified mail, return receipt requested, and directed to the respective parties at the following addresses:

If to the County:

If to Contractor:

Noble County Commissioners
Noble County Courthouse, 300 Courthouse Drive #1,

Perry, OK 73077

or at such other address as a party shall specify by like notice to the other party hereto. Notices shall be effective on the date of delivery.

- 8. Counterparts. This Contract may be executed in any number of counterparts, and when each party has signed and delivered to the other at least one (1) such counterpart, each counterpart shall be deemed an original, and when taken together with other signed counterparts, shall constitute one (1) agreement; provided, however, this Contract shall not be binding upon the parties hereto until signed by all of the parties.
- 9. Integration and Amendments. This Contract constitutes the entire agreement between the parties and may not be amended, altered, modified or changed in any way except in writing signed by all parties to this Contract and which specifically references this Contract. There are no other agreements, representations or warranties, whether oral or written, regarding the subject matter of this Contract. No course of dealings involving the parties hereto and no usage of trade shall be relevant or admissible to interpret, supplement, explain or in any way vary any of the terms expressly set forth in this Contract. Any amendment to this Contract shall be attached to this Contract and all of the terms in this Contract not addressed in the amendment shall remain in full force and effect.
- 10. Binding Effect. This Contract binds the parties and any successors and assigns of the parties.
- 11. Severability. If any one or more of the sections, sentences, clauses, or parts be held invalid for any reason, the invalidity of such section, sentence, clause, or part shall not affect nor prejudice the applicability and validity of any other provision of this Contract.

IN WITNESS WHEREOF, the parties hereto have caused this Contract to be executed on the day and year last written below.

Date: _____

Noble County Commissioners,

Chairman

(SEAL)

ATTEST:

County Clerk

Approved as to form:

District Attorney

Date: _____

_____,
a(n) _____

Signature

Printed Name

Title

ATTEST:

Secretary and/or Witness

State of Oklahoma)
) ss.
County of _____)

_____, of lawful age, being first duly sworn, on oath, says that (s)he is the agent authorized by the Contractor to submit the above Contract to Noble County. Affiant further states that Contractor has not paid, given or donated, or agreed to pay give or donate to any officer or employee of Noble County, any money or other valuable thing, either directly or indirectly, in the procuring of this Contract.

Signature

Printed Name/Title

Subscribed and sworn to before me this _____ day of _____, _____.

(SEAL)

Notary Public

My Commission Expires: _____

My Commission Number: _____

MAINTENANCE BOND

KNOW ALL MEN BY THESE PRESENT, that _____, Principal, and _____, a corporation organized under the laws of the State of _____, and authorized to transact business in the State of Oklahoma, as Surety, are held firmly bound unto Noble County, in the penal sum of _____ Dollars (\$_____) in lawful money of the United States of America, said sum being the contract price, for the payment of which, well and truly to be made, we bind ourselves and each of us, our heirs, executors, administrators, trustees, successors, and assigns, jointly and severally, firmly by these presents.

Dated this _____ day of _____, 20_____.

The condition of this obligation is such that:

WHEREAS, said Principal entered into a written contract with Noble County, dated _____, 20_____, for:

**Noble County
Bridge Project
CN 15
52E0350N3260007**

all in compliance with the plans and specifications therefor, made a part of said contract and on file in the Office of the County Clerk, located in the County Courthouse Building in Perry, Oklahoma.

NOW, THEREFORE, if said Principal shall pay or cause to be paid to Noble County, Oklahoma, all damage, loss, and expense which may result by reason of defective materials and/or workmanship in connection with said work, occurring within a period of **one (1) year** from and after acceptance of said project by Noble County, Oklahoma; then this obligation shall be null and void, otherwise to be and remain in full force and effect.

It is further expressly agreed and understood by the parties hereto that no changes or alterations in said contract and no deviations from the plan or mode of procedure herein fixed shall have the effect of releasing the sureties, or any of them, from the obligations of this bond.

IN WITNESS WHEREOF, the said Principal has caused these presents to be executed in its name and its corporate seal to be hereunto affixed by its duly authorized officers, and the same Surety has caused these presents to be executed in its name and its corporate seal to be hereunto affixed by its attorney-in- fact, duly authorized so to do, the day and year first above written.

Principal:

By: _____
Title

(SEAL)
ATTEST:

Secretary

Surety:

By: _____
Attorney-in-Fact

PERFORMANCE BOND

KNOW ALL MEN BY THESE PRESENT, that _____, Principal, and _____, a corporation organized under the laws of the State of _____, and authorized to transact business in the State of Oklahoma, as Surety, are held firmly bound Noble County, Oklahoma, in the penal sum of _____ Dollars (\$_____) in lawful money of the United States of America, for the payment of which, well and truly to be made, we bind ourselves and each of us, our heirs, executors, administrators, trustees, successors, and assigns, jointly and severally, firmly by these presents.

Dated this _____ day of _____, 20_____.

The condition of this obligation is such that:

WHEREAS, said Principal entered into a written contract with Noble County Oklahoma, dated _____, 20_____, for:

**Noble County
Bridge Project
CN 15
52E0350N3260007**

all in compliance with the plans and specifications therefor, made a part of said contract and on file in the Office of the County Clerk, located in the County Courthouse Building in Perry, Oklahoma.

NOW, THEREFORE, if said Principal shall in all particulars, well, truly, and faithfully perform and abide by said contract and each and every covenant, condition, and part thereof and shall fulfill all obligations resting upon said principal by the terms of said contract and specifications and if said principal shall protect and save harmless Noble County, Oklahoma from any pecuniary loss resulting from the breach of any of the items, covenants and conditions of said contract resting upon said principal, then this obligation shall be null and void, otherwise to be and remain in full force and effect.

It is further expressly agreed and understood by the parties hereto that no changes or alterations in said contract and no deviations from the plan or mode of procedure herein fixed shall have the effect of releasing the sureties, or any of them, from the obligations of this bond.

IN WITNESS WHEREOF, the said Principal has caused these presents to be executed in its name and its corporate seal to be hereunto affixed by its duly authorized officers, and the same Surety has caused these presents to be executed in its name and its corporate seal to be hereunto affixed by its attorney-in-fact, duly authorized so to do, the day and year first above written.

Principal:

By:

Title

(SEAL)
ATTEST:

Secretary

Surety:

By:

Attorney-in-Fact

STATUTORY BOND

KNOW ALL MEN BY THESE PRESENT, that _____,
Principal, and _____, a corporation organized under the laws of the State of
_____, and authorized to transact business in the State of Oklahoma, as Surety, are held firmly bound unto
Noble County, Oklahoma, in the penal sum of _____ Dollars (\$
_____) in lawful money of the United States of America, for the payment of which, well and truly to be made,
we bind ourselves and each of us, our heirs, executors, administrators, trustees, successors, and assigns,
jointly and severally, firmly by these presents.

Dated this _____ day of _____, 20_____.

The condition of this obligation is such that:

WHEREAS, said Principal entered into a written Contract with Noble County Oklahoma,
dated _____, 20_____, for:

**Noble County
Bridge Project
CN 15
52E0350N3260007**

all in compliance with the plans and specifications therefor, made a part of said contract and on file in the
Office of the County Clerk, located in the County Courthouse Building in Perry, Oklahoma.

NOW, THEREFORE, if said Principal shall fail or neglect to pay all indebtedness incurred by said
Principal or subcontractors of said Principal who performs work in the performance of such contract, for labor
and materials and repairs to and parts of equipment used and consumed in the performance of said contract
within thirty (30) days after the same becomes due and payable, the person, firm, or corporation entitled
thereto may sue and recover on this bond, the amount so due and unpaid.

It is further expressly agreed and understood by the parties hereto that no changes or alterations in said
contract and no deviations from the plan or mode of procedure herein fixed shall have the effect of releasing
the sureties, or any of them, from the obligations of this bond.

IN WITNESS WHEREOF, the said Principal has caused these presents to be executed in its name and
its corporate seal to be hereunto affixed by its duly authorized officers, and the same Surety has caused these
presents to be executed in its name and its corporate seal to be hereunto affixed by its attorney-in-fact, duly
authorized so to do, the day and year first above written.

Principal:

By:

Title

(SEAL)
ATTEST:

Secretary

Surety:

By:

Attorney-in-Fact

NOTICE TO PROCEED

TO:

FROM: Noble County Commissioners, Noble County, Oklahoma

YOU ARE HEREBY NOTIFIED that all contract documents have been executed and accepted in relation to the contract on

**Noble County
Bridge Project
CN 15
52E0350N3260007**

entered into on the ___ day of _____, 20 ____, by and between the County and _____ and that work may now be commenced in accordance with said Contract. With a contract time of 120 calendar days, the completion date is the ___ day of _____, 20____.

DATED at Noble County, Oklahoma this ___ day of _____, 20____.

Noble County Commissioners, Noble County, Oklahoma

By: _____
Chairman

cc: County Clerk

INVOICE AFFIDAVIT

STATE OF _____)
) SS.
COUNTY OF _____)

The undersigned (architect, contractor, supplier, engineer, or supervisory official) of lawful age, being first duly sworn, on oath says that this invoice, claim or contract is true and correct. Affiant further states that the work, services, or materials as shown by this invoice or claim have been completed or supplied in accordance with the plans, specifications, orders or requests furnished to the affiant. Affiant further states that (s) he has made no payment, given or donated or agreed to pay, give or donate either directly or indirectly to any elected official, officer or employee of the State of Oklahoma, of money or any other thing of value to obtain payment or the award of this contract.

Noble County Bridge Project CN 15

Project Name

Project No.

Signature - Contractor or Supplier

Company Name (Print or Type)

Address

City, State, Zip

Subscribed and sworn to before me this _____ day of _____, 20_____.

_____, Notary Public

My Commission Expires: _____

48 HOURS BEFORE YOU DIG...
CALL OKIE
1-800-522-6543



OKLAHOMA ONE-CALL SYSTEM

Buried utilities are not necessarily shown. It is the contractor's responsibility to locate and preserve all utility services.

Contractor is responsible for contacting all utility companies prior to construction.

PLAN OF PROPOSED COUNTY BRIDGE FOR NOBLE COUNTY

BRIDGE PLANS
BRIDGE STRUCTURE NO. 52E0350N3260007
LOCAL NO. 15 OLD NBI NO. 02801

SHEET NO.	DESCRIPTION
1	TITLE
2	SUMMARY OF PAY QUANTITIES & GENERAL NOTES
3	ABUTMENT
4	I-BEAM SUPERSTRUCTURE TR2-2-00E

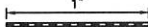
SCALES 
PLAN 1"=50'
PROFILE HOR. 1"=50'
VER. 1"=5'
LAYOUT MAP 1"= 2 MILES



BRIDGE LENGTH= 60 FT

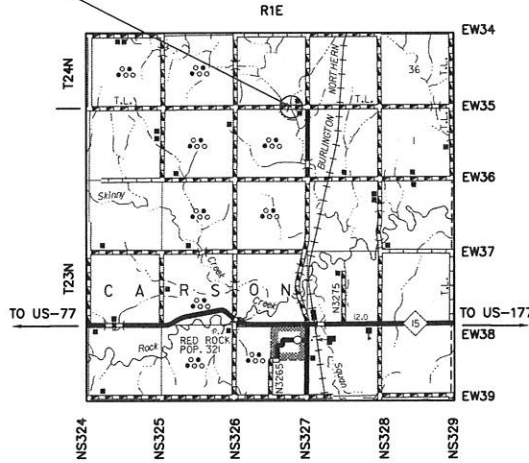

NOBLE COUNTY COMMISSIONERS

DATE _____

DIST. 1 _____

DIST. 2 _____

DIST. 3 _____

COUNTY CLERK _____

CONVENTIONAL SIGNS

- PROPOSED ROAD
- RAILROADS
- RANGE & TOWNSHIP
- SECTION LINES
- QUARTER SECTION LINES
- FENCES
- GROUND LINE
- EXISTING ROADS
- BASE LINE
- GRADE LINES
- TELEPHONE & TELEGRAPH
- POWER LINES
- OIL WELLS
- BUILDINGS
- DRAINAGE STRUCTURES—IN PLACE
- DRAINAGE STRUCTURES—NEW
- RIGHT-OF-WAY LINES—EXISTING
- RIGHT-OF-WAY LINES—NEW
- RIGHT-OF-WAY MARKERS—IN PLACE
- RIGHT-OF-WAY MARKERS—REMOVE & RESET
- RIGHT-OF-WAY MARKERS—NEW
- CONTROLLED ACCESS
- RIGHT-OF-WAY FENCE

PROJECT LENGTHS BASED ON CRL

BRIDGE LENGTH _ _ _ _ _ 60.00 FT.
PROJECT LENGTH _ _ _ _ _ 60.00 FT.
EXCEPTIONS _ _ _ _ _ NONE
EQUATIONS _ _ _ _ _ NONE

TYLER D. SCHRODER
REGISTERED PROFESSIONAL ENGINEER NO. 25837

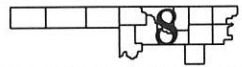

CIRCUIT ENGINEERING DIST. 8
2901 N. VAN BUREN
ENID, OK 73703
(580) 237-4810

*2009 OKLAHOMA STANDARD SPECIFICATIONS FOR HIGHWAY CONSTRUCTION—ENGLISH GOVERN.,
APPROVED BY THE U.S. DEPARTMENT OF TRANSPORTATION, FEDERAL HIGHWAY ADMINISTRATION, JANUARY 4, 2010.*

GENERAL NOTES

The road will be closed to traffic during construction of the bridge. Type III barricade and advance warning signs will be required at each end of the bridge construction zone and at road intersections each side of Bridge site. The county shall be responsible for placement and maintenance of all construction signs, barricade, lights, etc. according to the standards set forth in the Manual on Uniform Traffic Control Devices, 2009 Edition. All cost of necessary items for construction signing will be included in other items of work.

All construction and materials shall be in accordance with the 2009 Oklahoma Standards Specifications for Highway Construction.

Equipment for driving piles shall meet the requirements of Section 514.03 of the Standard Specifications. Length of piling shown is estimated. Piling under bridge seat shall have a capacity of 30 tons. Piling buildups, if required, will be paid for at the unit price bid for steel piling.

Bidders shall be responsible for the construction of the bridge using materials provided by the county.

Bidders may bid on the 60' steel beam type bridge shown on the plans or may bid other alternate types of bridge structures provided they meet the approval of the Engineer and the County Commission and provide equivalent clear roadway, waterway opening, and safety features as shown on the plans. If a bridge design different from those shown in the plans is low bid the contractor shall submit complete plans and specifications prepared by a registered engineer for review and approval by the County Commission prior to the award of contract. The County Commission reserves the right to reject any alternate type bridge or alternate design features which in their judgement would not provide a structure at this location which is equivalent to that shown on the plans.

The bid is good until the completion of the project.

The Top of Deck elevation should be approximately 18 feet above the Flowline elevation of the creek.

All material shall be new and delivered to the project site.

The new bridge alignment is to be approved by the County Commissioner or the Engineer.

The Contractor shall cut the beams to the required length and attach an estimated 288 Weld Studs to the top of the beams, price bid to be included in other items of work.

The Contractor shall remove the existing bridge and stack the beams on the Right of Way to become property of the county. The cost of removing the bridge shall be included in other items of work.

The bridge shall be constructed between July 1, 2017 and September 1, 2017.

CONSTRUCTION NOTES

- (1) QUANTITY CALCULATED AT 40' ASSUMING 20' PIECES, INCLUDES 16' FOR WASTE.
- (2) QUANTITY CALCULATED AT 120' ASSUMING 20' PIECES, INCLUDES 0' FOR WASTE.
- (3) QUANTITY CALCULATED AT 500' ASSUMING 20' PIECES, INCLUDES 48' FOR WASTE.
- (4) QUANTITY CALCULATED AT 60' ASSUMING 20' PIECES, INCLUDES 0' FOR WASTE.
- (5) QUANTITY CALCULATED AT 75' ASSUMING 25' PIECES, INCLUDES 11' FOR WASTE.
- (6) QUANTITY CALCULATED AT 800' ASSUMING 20' PIECES, INCLUDES 13' FOR WASTE.
- (7) QUANTITY CALCULATED AT 140' ASSUMING 20' PIECES, INCLUDES 16' FOR WASTE.
- (8) QUANTITY CALCULATED AT 2020' ASSUMING 20' PIECES, INCLUDES 5' FOR WASTE.
- (9) QUANTITY CALCULATED AT 9140' ASSUMING 20' PIECES, INCLUDES 7' FOR WASTE.
- (10) 96 - 2" CONTINUOUS SLAB BOLSTERS MAY BE SUBSTITUTED FOR 4" REBAR CHAIRS. BOLSTERS ASSUMED TO BE 5' LONG.
- (11) THE PAY ITEM "TUBULAR RAIL" IS TO INCLUDE ALL HARDWARE REQUIRED TO ATTACH THE TWO 12 GA. W BEAM MEMBERS WELDED AS SHOWN IN STANDARD TR2-2.
- (12) QUANTITY IS ESTIMATED AS 78 SHEETS OF 1'-7 5/8" WIDE X 25' LONG.
- (13) THE PAY ITEM "DECK FORM" IS TO BE PRIME MATERIAL MEETING PLAN SPECIFICATIONS. QUANTITY IS ESTIMATED AS 25 SHEETS OF 24' LONG X 3' WIDE.
- (14) QUANTITY CALCULATED AT 160' ASSUMING 20' PIECES, INCLUDES 26' FOR WASTE.
- (15) QUANTITY CALCULATED AT 55 C.Y., INCLUDES 5 C.Y. FOR WASTE. CLASS AA CONCRETE SHALL INCLUDE THE COST OF BOTH PURCHASING AND PLACING THE CONCRETE.

RESPONSIBILITIES OF COUNTY FORCES

- Moving and replacing fence if required.
- Providing for relocation of utilities, if necessary.
- Obtaining right-of-way if required.
- Placing guardrail beyond bridge ends.
- Placing approach embankments and surface.
- Providing 6-36"x135# x67' long Beams to the project site.

Contractor to call Okie 1-800-522-6543 for utility location before construction begins.

DESIGN DATA

CONCRETE: CLASS 'AA' f'c=4,000 psi
 REINFORCING STEEL: (GR. 60) fy=60,000 psi
 STRUCTURAL STEEL: (A 36) fy=36,000 psi
 STRUCTURAL STEEL: (BEAMS) fy=36,000 psi
 DESIGN-AASHTO Standard Specifications for Highway Bridges 1999
 and American Welding Society Specifications

PAY QUANTITIES

BRIDGE (A): 60' LONG X 30' OUT TO OUT SKEW 90°		
ITEM	UNIT	QUANTITY
HP 10" X 42# (12-40' PCS), Piles	L.F.	480.00
HP 12" X 53# (12-40' PCS), Piles	L.F.	480.00
HP 12" X 53# (2-32' PCS), Bent Caps	L.F.	64.00
5 1/2" X 1/2" FLAT, Bent Cap Stiffener	(1) L.F.	40.00
8" X 3/8" FLAT, Deck Sides	(2) L.F.	120.00
C8" X 11.5# CHANNEL, Backwall Bracing	(3) L.F.	500.00
C10" X 15 1/3# CHANNEL, Deck Ends	(4) L.F.	60.00
C12" X 25# CHANNEL, Wing Cap	(5) L.F.	75.00
3" X 3" X 1/4" ANGLE	(6) L.F.	800.00
5" X 3" X 1/4" ANGLE	(7) L.F.	140.00
REBAR, #4	(8) L.F.	2,020.00
REBAR, #5	(9) L.F.	9,140.00
SLAB BOLSTERS, 1"	EA.	96.00
STEEL REBAR CHAIRS, 4"	(10) EA.	144.00
REBAR TIES, 6"	ROLL	1.00
WELD STUDS, 3/4" X 4"	EA.	288.00
WELD STUDS, 5/8" X 6"	EA.	180.00
TUBULAR RAIL	(11) L.F.	120.00
W-BEAM END SECTION (FLARED)	E.A.	4.00
BACKWALL SHEETING, INTERLOCKING GALV. 10 GA.	(12) S.F.	3,189.00
GALV. DECK FORM	(13) S.F.	1,800.00
GUARDRAIL POST, W 6" X 20#	(14) L.F.	160.00
CLASS AA CONCRETE	(15) C.Y.	55.00

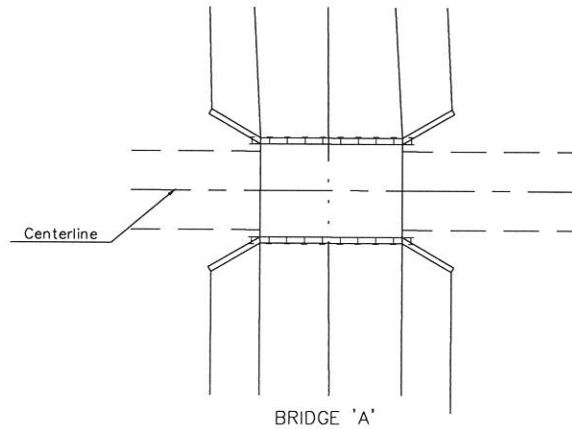

GENERAL NOTES

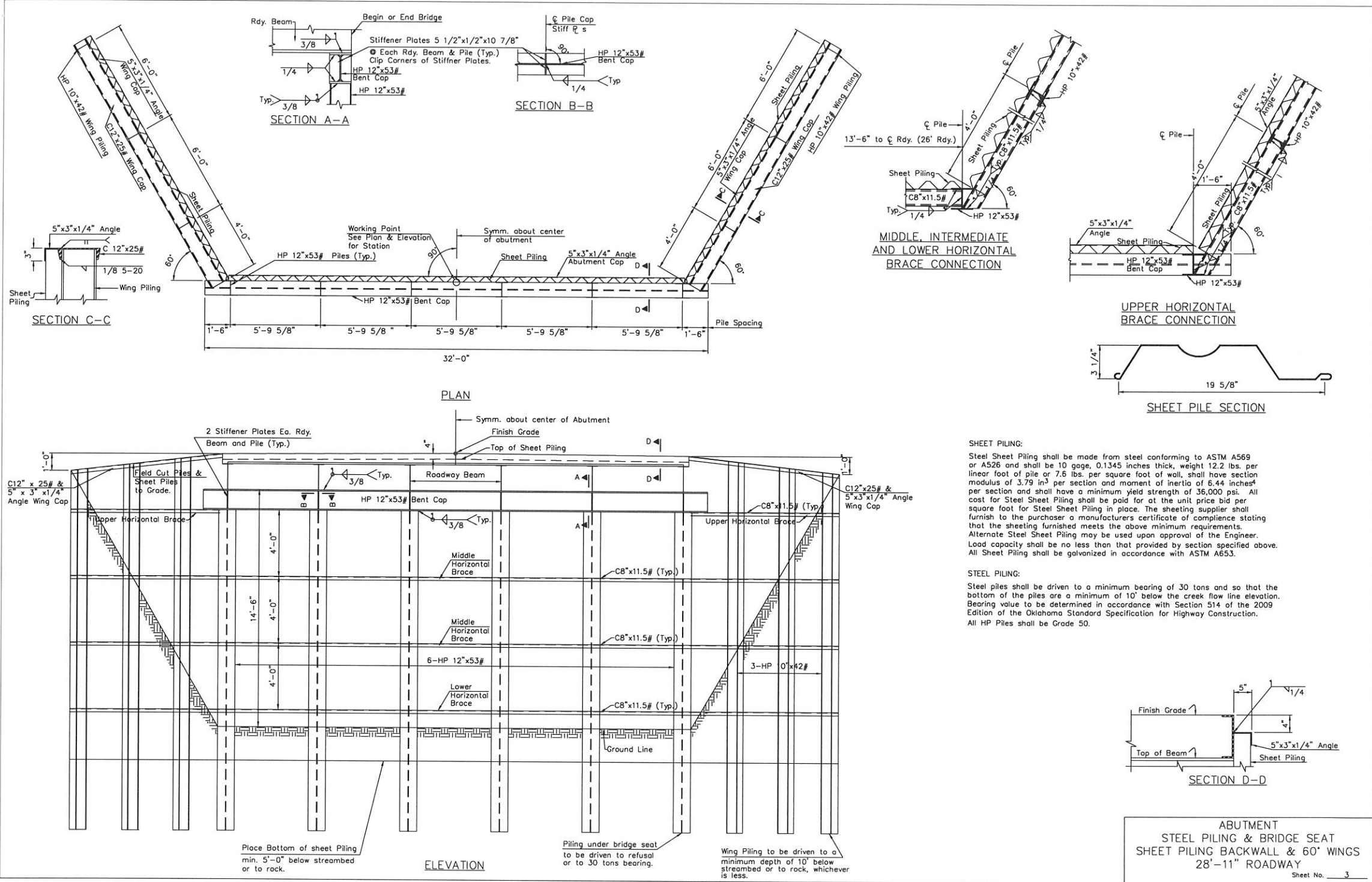

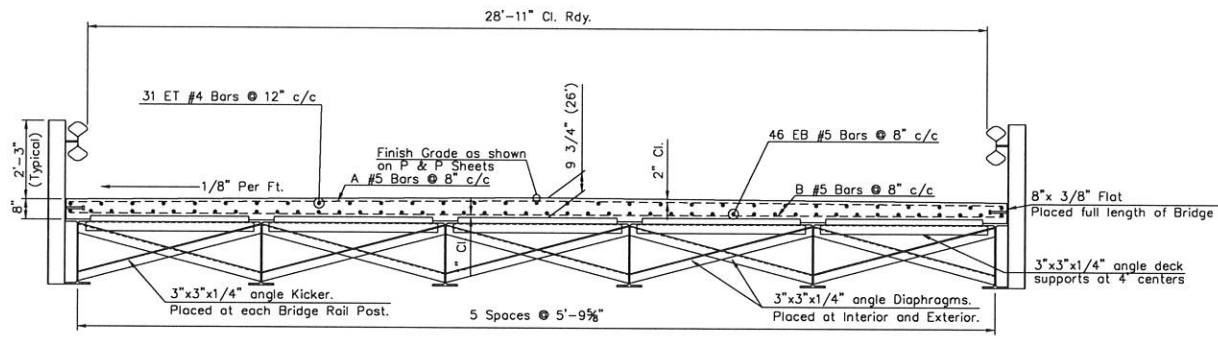

BRIDGE SECTION
Diaphragms at ends and 1/3 points of 60' span.

The minimum lap splice length for #5 reinforcing steel bars shall be 2'-6", and the minimum lap splice length for #4 reinforcing steel bars shall be 1'-8". The lap splices shall be staggered.

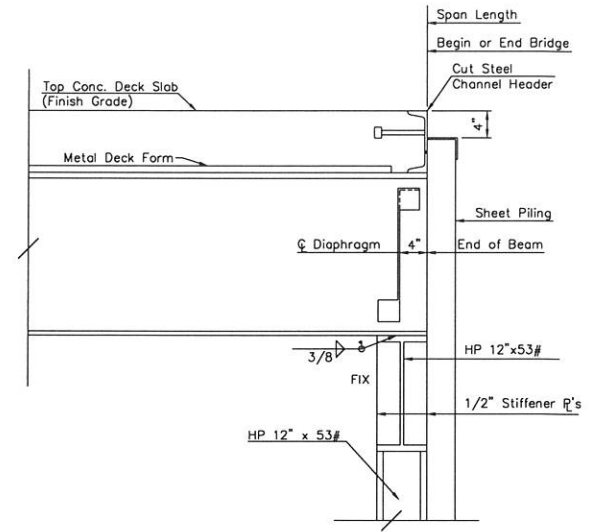

SHEET PILING ABUTMENTS

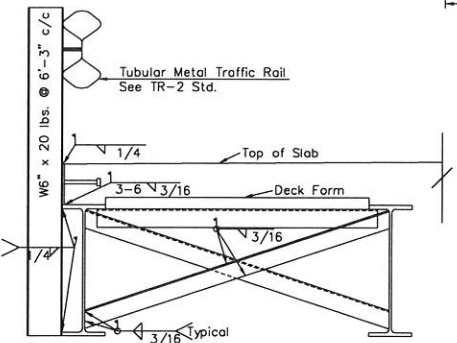

TR-2 TRAFFIC RAIL & DIAPHRAM DETAIL

(Rail, Posts & all fastener hardware to be included in price bid for Handrail)

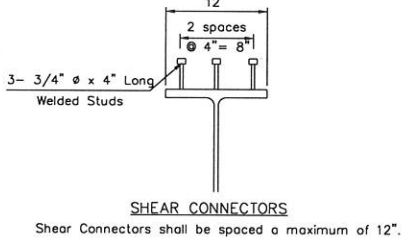

SHEAR CONNECTORS

Shear Connectors shall be spaced a maximum of 12".

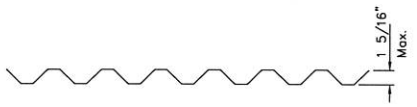

METAL DECK FORM DETAIL

Deck Form shall be tough tempered cold rolled steel, sheet formed to a corrugated rib pattern with a maximum depth of 1 5/16". The steel shall have an average minimum yield strength of not less than 80,000 psi. Steel shall conform to A653, Grade E with Zinc coating conforming to ASTM A525 G90. Deck Form shall have a minimum Moment of Inertia = 0.204 in⁴/ft and a minimum Section Modulus = 0.119 in³/ft. Deck Form sections shall be placed with ribs perpendicular to beams and with side laps up. Allow 3" for end laps and center all end laps over beams. Do not allow bottom sheets to extend beyond edge of support flange. Install adjacent rows end to end, side lapping one corrugation rib with previously placed section.

Deck Form material shall be electric arc welded to the supporting steel beams and adjoining deck sheets in accordance with manufacturer's specifications. Weld shall not exceed 12" on center at end lap joints and 18" on center on beams. All skew cutting shall be done in the field.

Deck Forms shall have holes field cut to allow shear connectors to protrude through the forms. Do not flame cut. Alternate stay-in-place forms may be used provided they are prepared by a registered engineer and approved by the County Commission. All costs associated with the use of an alternate design shall be at the contractors expense.



NOTE: Interior Diaphragms to be located at mid span for 20', 25', 30', 35', and 40' spans and at 1/3 span points for 45', 50', 55', and 60' spans and at 1/4 span points for 65', 70', 75', and 80' spans.

DIAPHRAM LOCATIONS-SKEWED BRIDGE

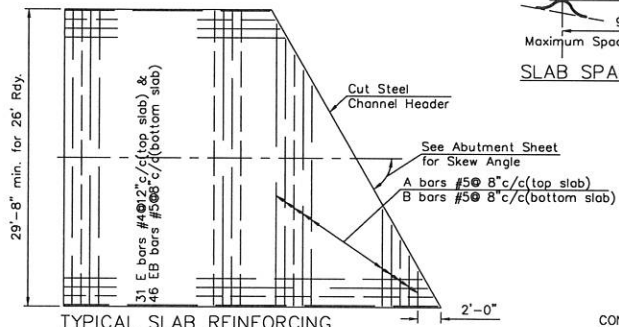

TYPICAL SLAB REINFORCING FOR SKEWED BRIDGE

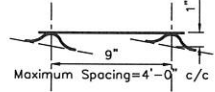

SLAB SPACER DETAIL

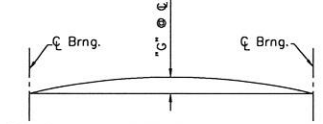

DEAD LOAD DEFLECTION DIAGRAM

NOTE: The Contractor shall adjust the Finish Grade Line to provide for the Dead Load Deflection as shown above.

LENGTH OF A & B BARS	
SPAN	26' CL. RDY.
20' to 30'	29'-8"
35' to 50'	29'-8"
55' to 70'	29'-8"
75' to 80'	29'-8"

CONCRETE DECK SLAB:
Class "AA" Concrete and Maximum Aggregate 1" ϕ . All construction shall conform to the 2009 Oklahoma Standard Specifications. Surface of roadway shall slope 1/8" per foot each way from centerline of bridge. Transverse reinforcing steel in the floor shall begin and end a maximum of 2" from end of concrete panels. All reinforcing steel bars in top of slab shall be supported on approved metal high chairs. The spacing of the high chairs shall be a maximum of 4'-0" on center. Bottom layers of reinforcing steel shall be supported on continuous steel slab spacers as shown. Longitudinal bars shall begin and end 1" from end of slab.

DESIGN DATA

CONCRETE: CLASS "AA" $f'_c=4,000$ psi
 REINFORCING STEEL: (Gr. 60) $f_y=60,000$ psi
 STRUCTURAL STEEL: (A 36) $f_y=36,000$ psi
 STRUCTURAL STEEL: (BEAMS) $f_y=36,000$ psi
 NOTE: MINIMUM COMPRESSIVE STRENGTH FOR CLASS AA CONCRETE SHALL BE 4,000 psi AT 28 DAYS.

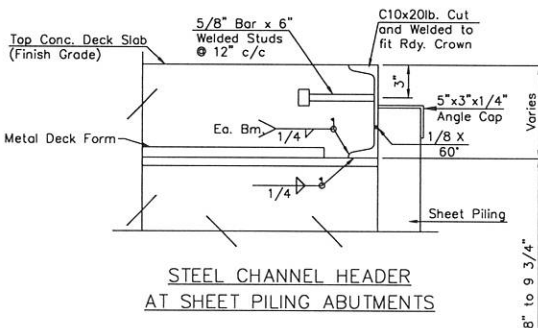

STEEL CHANNEL HEADER AT SHEET PILING ABUTMENTS

I-BEAM SUPERSTRUCTURE COMPOSITE CONCRETE DECK 28'-11" CL. RDY.

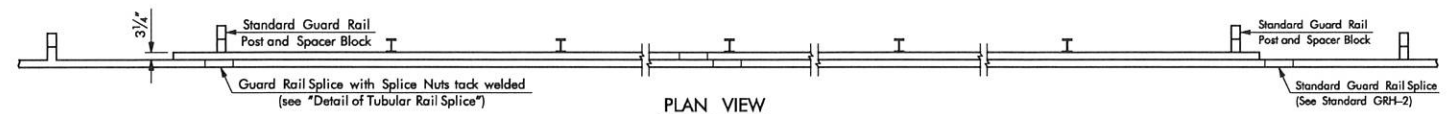

PLAN VIEW

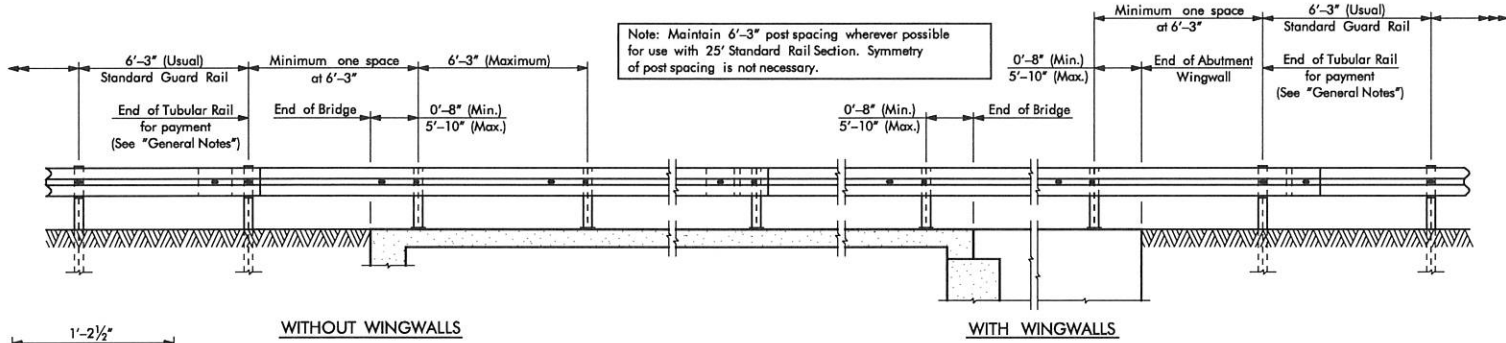

Note: Maintain 6'-3" post spacing wherever possible for use with 25' Standard Rail Section. Symmetry of post spacing is not necessary.

WITHOUT WINGWALLS

WITH WINGWALLS

GENERAL NOTES:
 THIS RAIL HAS BEEN SUCCESSFULLY EVALUATED BY FULL SCALE IMPACT TESTS CONDUCTED IN ACCORDANCE WITH NCHRP REPORT 153. TEST DOCUMENTATION MAY BE FOUND IN RESEARCH REPORT 230-1, 'TUBULAR W-BEAM BRIDGE RAIL', OF RESEARCH STUDY 2-5-78-230 'BRIDGE RAIL TO CONTAIN HEAVY TRUCKS AND BUSES', TEXAS TRANSPORTATION INSTITUTE, OCTOBER 1978.
 TUBULAR METAL TRAFFIC RAIL SHALL EXTEND ACROSS THE BRIDGE AND CONNECT TO AT LEAST THE FIRST SOIL EMBEDDED POST AT EACH END OF THE STRUCTURE. APPROACH GUARD RAIL POSTS SHALL BE SPACED AT 6'-3" CENTERS ADJACENT TO THE TUBULAR RAIL SINCE THE FLEXIBILITY OF SINGLE FACE GUARD RAIL AND TUBULAR RAIL IS SIMILAR. (DO NOT INSTALL ADDITIONAL POSTS AT 3'-1 1/2" CENTERS).
 RAIL POSTS ON THE BRIDGE SHALL BE SPACED AT 6'-3" CENTERS WHEREVER POSSIBLE AND SET PERPENDICULAR TO THE ROADWAY PROFILE GRADE AND CROSS SLOPE. AT THE CONTRACTOR'S OPTION, THE POST MAY BE PLACED AT EITHER OF THE POST MOUNTING SLOTS SHOWN. GROUT OR SHIM PLATES MAY BE USED UNDER THE BASE PLATE IF NECESSARY TO SECURE PROPER ALIGNMENT OF THE RAIL.

RAIL POSTS ON THE BRIDGE SHALL BE SPACED AT 6'-3" CENTERS WHEREVER POSSIBLE AND SET PERPENDICULAR TO THE ROADWAY PROFILE GRADE AND CROSS SLOPE. AT THE CONTRACTOR'S OPTION, THE POST MAY BE PLACED AT EITHER OF THE POST MOUNTING SLOTS SHOWN. GROUT OR SHIM PLATES MAY BE USED UNDER THE BASE PLATE IF NECESSARY TO SECURE PROPER ALIGNMENT OF THE RAIL.

TUBULAR W-BEAM RAIL MEMBER IS TO BE FABRICATED FROM STANDARD 25' GUARD RAIL ELEMENTS. W-BEAM MEMBER SHALL BE 12 GAGE STEEL WITH NOMINAL THICKNESS OF 0.1046" EXCLUSIVE OF PROTECTIVE COATING. ADDITIONAL POST MOUNTING SLOTS ARE TO BE MADE IN EACH MEMBER 15" FROM THE STANDARD SLOTS AT 6'-3" CENTERS. TOP AND BOTTOM SEAMS SHALL BE BUTT WELDED 6" AT 12" SPACING. CONTINUOUS SEAM WELDING IS ALSO ACCEPTABLE. WELDS SHALL BE CHIPPED, CLEANED, AND PAINTED IN ACCORDANCE WITH SECTION 732.01(B) OF THE STANDARD SPECIFICATIONS. ALL BRIDGE RAILING HARDWARE SHALL CONFORM TO SECTIONS 732.01 AND 732.03 OF THE STANDARD SPECIFICATIONS.

THE TUBULAR RAIL SHALL EXTEND ACROSS ALL JOINTS (FIXED AND EXPANSION) WITH NO CHANGE IN POST SPACING OR CONTINUITY. AT EXPANSION JOINTS OF 1 1/4" OR LESS, THE SPICE BOLTS ON THE SPICE NEAREST THE JOINT AND ALL POST MOUNTING BOLTS BETWEEN THE EXPANSION JOINT AND THIS SPICE SHALL BE SNUGLY TIGHTENED TO ALLOW FOR RAIL EXPANSION. AT EXPANSION JOINTS OVER 1 1/4", THE BOLT TREATMENT WILL BE THE SAME AS FOR JOINTS 1 1/4" OR LESS WITH SUITABLY LONGER SPICE HOLES PROVIDED.

3/8" SPICE NUTS SHALL BE TACK WELDED ON THE INSIDE OF THE TUBULAR RAIL SECTION AT ALL RAIL SPLICES. THE NUTS MUST BE TACKED APPROX 3/32" OFF THE CENTER OF THE BOLT SLOT TOWARD THE OUTSIDE OF THE TUBULAR RAIL. AT THE CONTRACTOR'S OPTION, THE NUTS MAY BE TACK WELDED TO A BENT SHEET METAL POSITIONER AS SHOWN IN THE DETAILS. OTHER SUITABLE POSITIONING METHODS OR DEVICES MAY BE SUBSTITUTED FOR THE METHODS NOTED. THE COMPLETE SPICE SHALL HAVE 16-5/8" SPICE BOLTS. FOR DETAIL OF SPICE BOLT SEE ROADWAY STD. GRH-2.

ANCHOR BOLTS SHALL BE 3/8" DIA. A-307 (OR A-36) THREADED RODS WITH TACK WELDED NUTS WITH HEX NUTS AND WASHERS AS SHOWN. THREADED RODS MAY BE 0.781" MIN. DIA. WITH ROLLED THREADS. NUTS SHALL CONFORM TO A-307 REQUIREMENTS AND MAY BE TAPPED OR CHASED AFTER GALVANIZING. BOLTS AND NUTS SHALL HAVE CLASS 2A AND 2B FIT TOLERANCES.

SHOP DRAWINGS SHOWING DIMENSIONS AND DETAILS OF THE COMPLETE TUBULAR METAL TRAFFIC RAIL SHALL BE SUBMITTED TO THE BRIDGE ENGINEER FOR APPROVAL. BASIS OF PAYMENT: THE TUBULAR METAL TRAFFIC RAIL WILL BE MEASURED FOR PAYMENT BY THE LINEAR FOOT COMPLETE IN PLACE FROM END TO END OF TUBULAR RAILING SECTION ON EACH SIDE OF BRIDGE. PAYMENT WILL BE MADE AT THE CONTRACT UNIT PRICE FOR:

TUBULAR METAL TRAFFIC RAIL L.F. WHICH PRICE SHALL INCLUDE ALL COST OF TUBULAR W-BEAM RAIL, POSTS, ANCHOR BOLTS, WELDING, NUTS, BOLTS, WASHERS, CONNECTING PLATES, MISCELLANEOUS HARDWARE, LABOR, AND INCIDENTALS NECESSARY TO INSTALL THE TRAFFIC RAIL AS NOTED AND SPECIFIED.

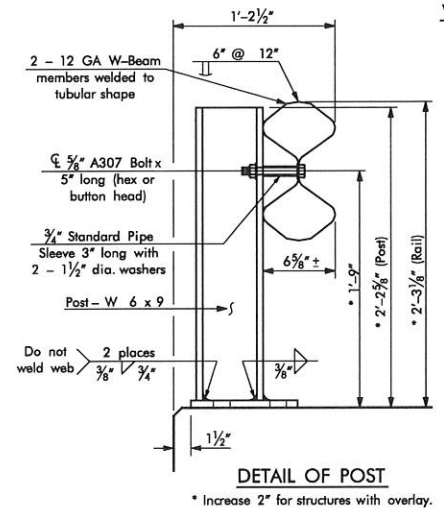

DETAIL OF POST

* Increase 2" for structures with overlay.

Note: Posts shall be welded only at locations shown. NO ADDITIONAL WELDING WILL BE PERMITTED.

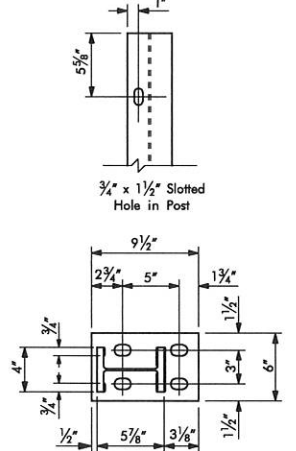

DETAIL OF BASE PLATE

Plate 9 1/2" x 5/8" x 0'-6" with 1" x 1 1/2" Slotted Holes

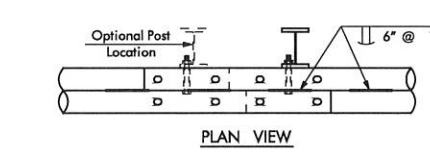

PLAN VIEW

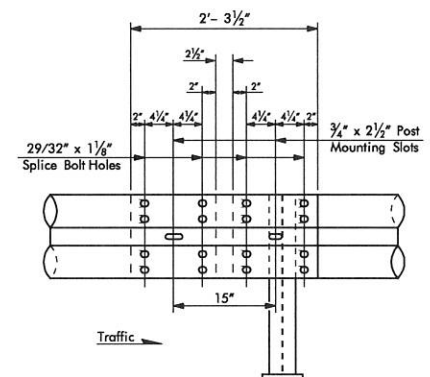

ELEVATION VIEW

DETAIL OF TUBULAR RAIL SPICE

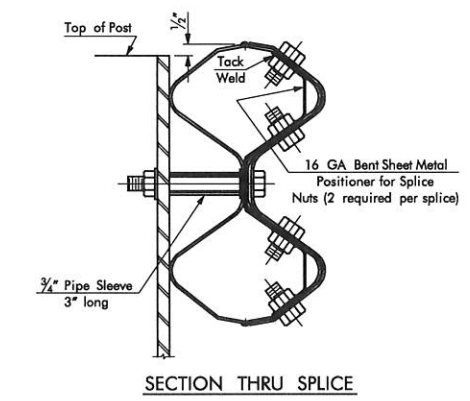

SECTION THRU SPICE

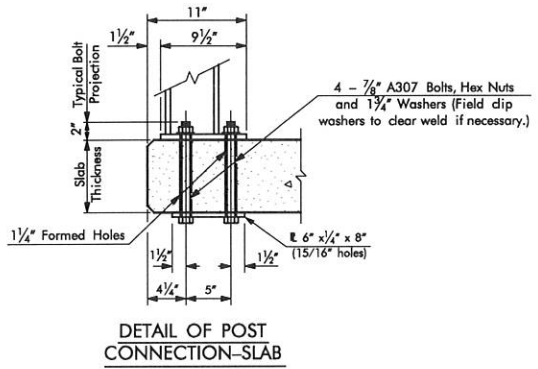

DETAIL OF POST CONNECTION-SLAB

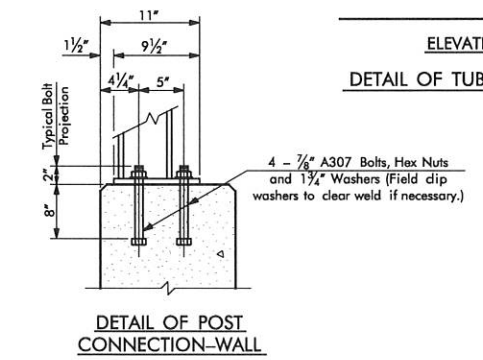

DETAIL OF POST CONNECTION-WALL

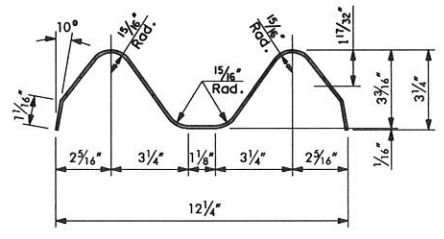

W-BEAM DETAIL

APPROVED BY BRIDGE ENGINEER: _____ DATE: _____

OKLAHOMA DEPT. OF TRANSPORTATION
 COUNTY BRIDGE STANDARD (ENGLISH)
 TUBULAR METAL TRAFFIC RAIL