

APRON BAR LIST

ONE APRON SHOWN

MARK	SIZE	FORM	10' SPAN			12' SPAN			14' SPAN			16' SPAN			18' SPAN		
			QTY.	LENGTH	REMARKS	QTY.	LENGTH	REMARKS	QTY.	LENGTH	REMARKS	QTY.	LENGTH	REMARKS	QTY.	LENGTH	REMARKS
AC1	#4	BNT	2	3'-8"		2	3'-8"		2	3'-8"		2	3'-8"		2	3'-8"	
AC2	#4	BNT	2	3'-8"		2	3'-8"		2	3'-8"		2	3'-8"		2	3'-8"	
AD1	#4	STR	2	66'-0"		2	66'-0"		2	66'-0"		2	66'-0"		2	66'-0"	
AL1	#4	STR	76	34'-9"		90	34'-9"		104	34'-9"		118	34'-9"		132	34'-9"	
AL2	#4	STR	104	17'-2 1/2" AVG.	2'-6" TO 31'-11"	104	17'-2 1/2" AVG.	2'-6" TO 31'-11"	104	17'-2 1/2" AVG.	2'-6" TO 31'-11"	104	17'-2 1/2" AVG.	2'-6" TO 31'-11"	104	17'-2 1/2" AVG.	2'-6" TO 31'-11"
AL3	#4	STR	4	32'-9"		4	32'-9"		4	32'-9"		4	32'-9"		4	32'-9"	
AT1	#4	STR	4	95'-8"	①	4	102'-7"	①	4	109'-6"	①	4	116'-5"	①	4	125'-10"	②
AT2	#4	STR	19	79'-4" AVG.	① 63'-9" TO 94'-11"	23	82'-9 1/2" AVG.	① 63'-9" TO 101'-10"	27	86'-3" AVG.	① 63'-9" TO 108'-9"	31	89'-8 1/2" AVG.	① 63'-9" TO 115'-8"	2	124'-2 1/2" AVG.	② 123'-4" TO 125'-1"
AT3	#5	STR	19	79'-4" AVG.	① 63'-9" TO 94'-11"	23	82'-9 1/2" AVG.	① 63'-9" TO 101'-10"	27	86'-3" AVG.	① 63'-9" TO 108'-9"	31	89'-8 1/2" AVG.	① 63'-9" TO 115'-8"	2	124'-2 1/2" AVG.	② 123'-4" TO 125'-1"
AT4	#4	STR	13	49'-1" AVG.	38'-8" TO 59'-6"	9	52'-7" AVG.	45'-8" TO 59'-6"	5	56'-0 1/2" AVG.	52'-7" TO 59'-6"	1	59'-6"		30	94'-0 1/2" AVG.	① 68'-11" TO 119'-2"
AT5	#5	STR	13	49'-1" AVG.	38'-8" TO 59'-6"	9	52'-7" AVG.	45'-8" TO 59'-6"	5	56'-0 1/2" AVG.	52'-7" TO 59'-6"	1	59'-6"		30	94'-0 1/2" AVG.	① 68'-11" TO 119'-2"

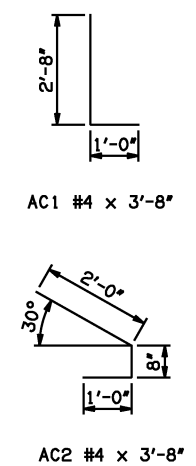

① INCLUDES 2'-6" LAP
 ② INCLUDES TWO 2'-6" LAPS
 ③ QUANTITY SHOWN REPRESENTS TWO SETS.

NOTE: SEE END SECTION DETAILS SHEET NO. 2 OF 3 FOR VARIABLE REINFORCING QUANTITIES.

END SECTION VARIABLE DIMENSIONS

SPAN	W	A	B	C	CW	D	E	F	G	H	LW	R	SW
10'	12"	12'-0"	2'-2 1/4"	3'-0"	93'-6"	3'-3 1/4"	21'-9 3/4"	22'-5 3/4"	22'-8 3/4"	39'-10"	62'-8 3/4"	34'-0"	32'-2 3/4"
12'	12"	14'-0"	2'-5 1/2"	3'-3 1/4"	100'-5 1/4"	3'-6 1/4"	25'-6 1/2"	26'-2 1/2"	26'-5 3/4"	46'-9 1/4"	62'-8 3/4"	40'-0"	32'-2 3/4"
14'	12"	16'-0"	2'-8 3/4"	3'-6 1/4"	107'-4 1/2"	3'-9 1/2"	29'-3 1/4"	29'-11 1/4"	30'-2 1/2"	53'-8 1/4"	62'-8 3/4"	46'-0"	32'-2 3/4"
16'	13"	18'-0"	2'-11 1/4"	3'-11 1/4"	114'-3 1/2"	4'-0 3/4"	33'-0 3/4"	33'-9 3/4"	33'-11 1/4"	60'-9 3/4"	62'-6 3/4"	52'-2"	32'-0 3/4"
18'	14"	19'-0"	2'-2"	3'-4 1/4"	121'-2 3/4"	3'-4"	35'-10"	36'-8 1/4"	36'-8"	67'-11 1/4"	62'-4 3/4"	58'-4"	31'-10 3/4"

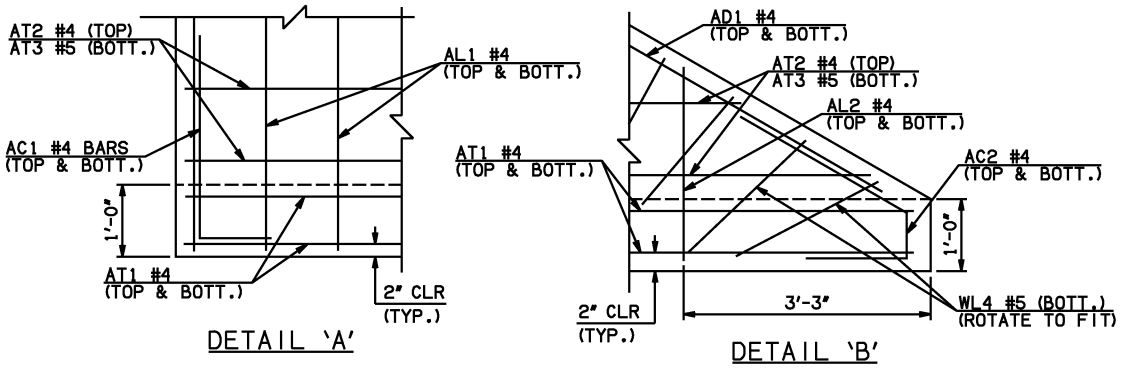

APPROVED BY BRIDGE ENGINEER *Scott Luch* DATE 4/2/10

OKLAHOMA DEPT. OF TRANSPORTATION
BRIDGE STANDARD (ENGLISH)

RCB CULVERTS - END SECTION DETAILS
 TRIPLE CELL - 9'-0" HEIGHT - 30°

SHEET NO. 1 OF 3

2009 SPECIFICATIONS	RCB-E3-H9-30-1	01E
		B-765E