

| DESCRIPTION | REVISIONS | DATE |
|-------------|-----------|------|
| | | |

| WINGWALL DIMENSIONS | | | |
|---------------------|-----|--------|--------|
| SPAN | W | D | F |
| 8' | 12" | 7 1/4" | 3 1/2" |
| 10' | 12" | 7 1/4" | 3 1/2" |
| 12' | 12" | 7 1/4" | 3 1/2" |
| 14' | 12" | 7 1/4" | 3 1/2" |
| 16' | 13" | 5 1/4" | 5 1/4" |

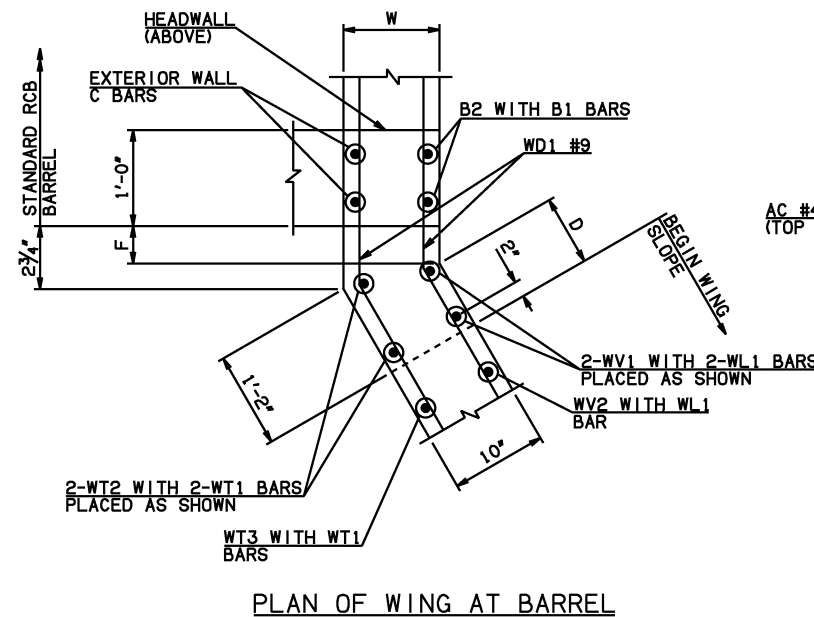

| APRON VARIABLES | | | | | | |
|-----------------|--------|--------|--------|--------|--------|--|
| SPAN | DIM. R | DIM. Q | QTY. J | QTY. K | QTY. N | |
| 8' | 19'-0" | 26'-7" | 30 | 0 | 22 | |
| 10' | 23'-0" | 28'-7" | 30 | 0 | 26 | |
| 12' | 27'-0" | 30'-7" | 1 | 29 | 30 | |
| 14' | 31'-0" | 32'-7" | 4 | 26 | 34 | |
| 16' | 35'-2" | 34'-7" | 8 | 22 | 38 | |

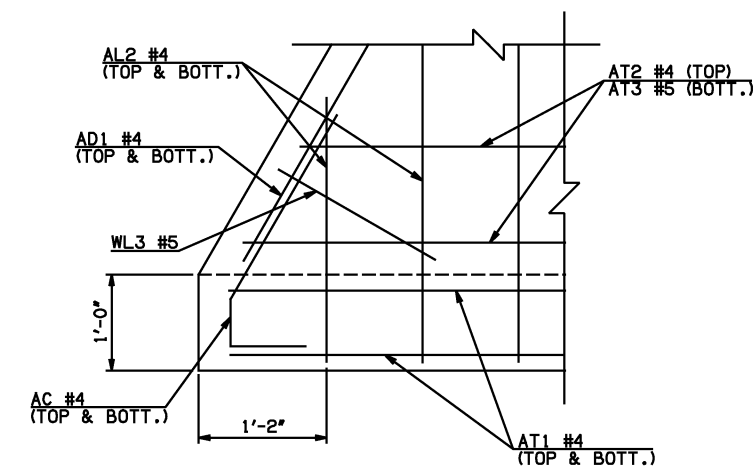
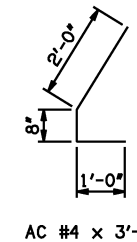

| WINGWALL BAR LIST | | | | | |
|----------------------------------|------|------|------|------------------|-----------------|
| ONE WINGWALL SHOWN; TWO REQUIRED | | | | | |
| MARK | SIZE | QTY. | FORM | LENGTH | REMARKS |
| WD1 | #9 | 18 | BNT | 8'-4" | |
| WH1 | #4 | 2 | STR | 34'-6" | |
| WH2 | #4 | 18 | STR | 17'-10 1/2" AVG. | 4'-0" TO 31'-9" |
| WH3 | #5 | 2 | STR | 34'-8" | |
| WL1 | #6 | 10 | BNT | 12'-9" | |
| WL2 | #5 | 29 | BNT | 10'-0" | |
| WL3 | #5 | 10 | BNT | 4'-8" AVG. | 3'-4" TO 6'-0" |
| WT1 | #4 | 25 | STR | 2'-10" | |
| WT2 | #4 | 2 | STR | 10'-0" | |
| WT3 | #4 | 23 | STR | 6'-8" AVG. | 3'-6" TO 9'-10" |
| WT4 | #4 | 10 | STR | 2'-8" AVG. | 1'-4" TO 4'-0" |
| WV1 | #5 | 2 | STR | 10'-0" | |
| WV2 | #5 | 23 | STR | 6'-8" AVG. | 3'-6" TO 9'-10" |
| U1 | #4 | 1 | BNT | 2'-8" | |

- ① 4-SETS OF 16-AL2 BARS REQUIRED
- ② 2-SETS OF 9-WH2 BARS REQUIRED
- ③ INCLUDES 2'-6" LAP

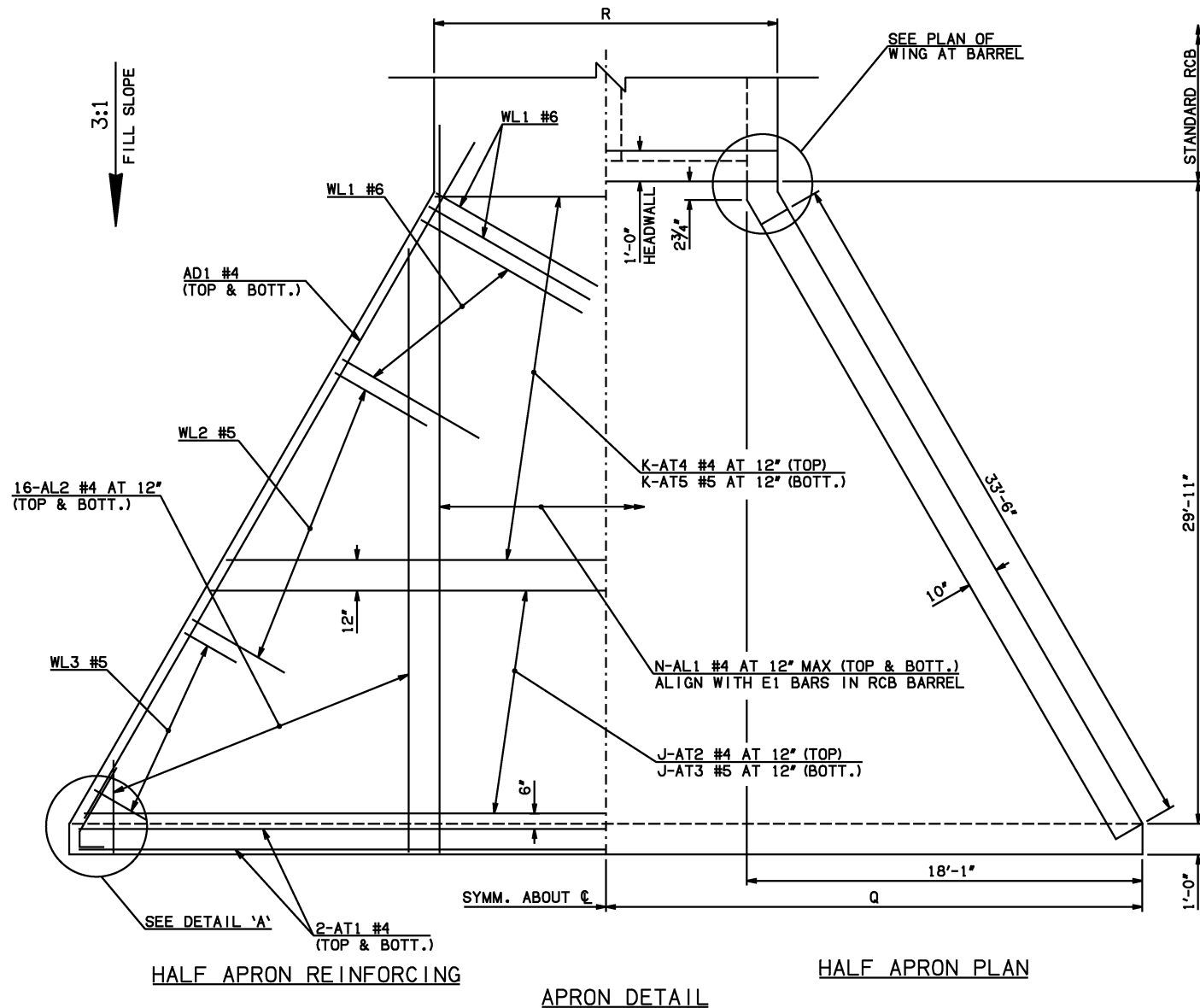

APRON AND HEADWALL BAR LIST

| APRON AND HEADWALL BAR LIST | | | | | | | | | | | | | | | | | |
|----------------------------------|------|------|---------|-----------------|-------------------|----------|-----------------|-------------------|----------|-----------------|-------------------|----------|-----------------|---------------------|----------|------------------|---------------------|
| ONE APRON AND ONE HEADWALL SHOWN | | | | | | | | | | | | | | | | | |
| MARK | SIZE | FORM | 8' SPAN | | | 10' SPAN | | | 12' SPAN | | | 14' SPAN | | | 16' SPAN | | |
| | | | QTY. | LENGTH | REMARKS | QTY. | LENGTH | REMARKS | QTY. | LENGTH | REMARKS | QTY. | LENGTH | REMARKS | QTY. | LENGTH | REMARKS |
| AC | #4 | BNT | 4 | 3'-8" | | 4 | 3'-8" | | 4 | 3'-8" | | 4 | 3'-8" | | 4 | 3'-8" | |
| AD1 | #4 | STR | 4 | 36'-6" | | 4 | 36'-6" | | 4 | 36'-6" | | 4 | 36'-6" | | 4 | 36'-6" | |
| AL1 | #4 | STR | 44 | 32'-8" | | 52 | 32'-8" | | 60 | 32'-8" | | 68 | 32'-8" | | 76 | 32'-8" | |
| AL2 | #4 | STR | 64 | 15'-5 1/2" AVG. | 2'-6" TO 28'-5" | 64 | 15'-5 1/2" AVG. | 2'-6" TO 28'-5" | 64 | 15'-5 1/2" AVG. | 2'-6" TO 28'-5" | 64 | 15'-5 1/2" AVG. | 2'-6" TO 28'-5" | 64 | 15'-5 1/2" AVG. | 2'-6" TO 28'-5" |
| AT1 | #4 | STR | 4 | 52'-10" | | 4 | 56'-10" | | 4 | 63'-4" | ③ | 4 | 67'-4" | ③ | 4 | 71'-4" | ③ |
| AT2 | #4 | STR | 30 | 35'-7" AVG. | 18'-10" TO 52'-4" | 30 | 39'-7" AVG. | 22'-10" TO 56'-4" | 1 | 62'-10" | ③ | 4 | 65'-1" AVG. | 63'-4" TO 66'-10" ③ | 8 | 66'-9 1/2" AVG. | 62'-9" TO 70'-10" ③ |
| AT3 | #5 | STR | 30 | 35'-7" AVG. | 18'-10" TO 52'-4" | 30 | 39'-7" AVG. | 22'-10" TO 56'-4" | 1 | 62'-10" | ③ | 4 | 65'-1" AVG. | 63'-4" TO 66'-10" ③ | 8 | 66'-9 1/2" AVG. | 62'-9" TO 70'-10" ③ |
| AT4 | #4 | STR | 0 | | | 0 | | | 29 | 43'-0" AVG. | 26'-10" TO 59'-2" | 26 | 45'-3" AVG. | 30'-10" TO 59'-8" | 22 | 46'-11 1/2" AVG. | 34'-10" TO 59'-1" |
| AT5 | #5 | STR | 0 | | | 0 | | | 29 | 43'-0" AVG. | 26'-10" TO 59'-2" | 26 | 45'-3" AVG. | 30'-10" TO 59'-8" | 22 | 46'-11 1/2" AVG. | 34'-10" TO 59'-1" |
| CH | #4 | STR | 4 | 18'-8" | | 4 | 22'-8" | | 4 | 26'-8" | | 4 | 30'-8" | | 4 | 34'-10" | |
| CL1 | #4 | BNT | 22 | 4'-4" | | 26 | 4'-4" | | 30 | 4'-4" | | 34 | 4'-4" | | 38 | 4'-4" | |
| CL2 | #4 | BNT | 22 | 4'-3" | | 26 | 4'-3" | | 30 | 4'-3" | | 34 | 4'-3" | | 38 | 4'-3" | |

| QUANTITIES | | | | | | |
|-------------------|------|---------|----------|----------|----------|----------|
| ITEM | UNIT | 8' SPAN | 10' SPAN | 12' SPAN | 14' SPAN | 16' SPAN |
| CLASS AA CONCRETE | CY | 54.20 | 58.90 | 63.60 | 68.30 | 72.90 |
| REINFORCING STEEL | LB | 7400.00 | 7820.00 | 8260.00 | 8690.00 | 9140.00 |

NOTE: QUANTITIES ABOVE ARE FOR ONE END SECTION, WHICH IS COMPRISED OF ONE HEADWALL, ONE APRON, AND TWO WINGWALLS. INCLUDED IN REINFORCING STEEL PAY ITEM QUANTITY IS THE WEIGHT OF ADDITIONAL RCB BARREL REINFORCING STEEL REQUIRED AS SHOWN.

APPROVED BY BRIDGE ENGINEER *Scott J. Smith* DATE 4/2/10

OKLAHOMA DEPT. OF TRANSPORTATION
BRIDGE STANDARD (ENGLISH)
 RCB CULVERTS - END SECTION DETAILS
 DOUBLE CELL - 8'-0" HEIGHT - 0°
 SHEET NO. 1 OF 2

2009 SPECIFICATIONS | RCB-E2-H8-0-1 | 01E | B-610E