

DESCRIPTION	REVISIONS	DATE

SECTION DIMENSIONS					REINFORCING STEEL																						SECTION DIMENSIONS		QUANTITIES													
					A1-BARS				A2-BARS				B1-BARS				B2-BARS				C1-BARS				C2-BARS						E1-BARS AT 12" MAX.		E2-BARS AT 12" MAX.									
S	H	T	U	W	SIZE	SPA	LENGTH	WEIGHT PER FT.	SIZE	SPA	LENGTH	WEIGHT PER FT.	SIZE	SPA	*X*	*Y*	LENGTH	WEIGHT PER FT.	SIZE	SPA	*X*	*Y*	LENGTH	WEIGHT PER FT.	SIZE	SPA	LENGTH	WEIGHT PER FT.	NO.	SIZE	WEIGHT PER FT.	NO.	SIZE	WEIGHT PER FT.	S	H	CONC. (C.Y.)	REINF. (LB.)				
20'	8'	18"	19"	15"	#9	6"	22'-2"	301.5	#4	6"	22'-2"	59.2	#7	6"	3'-4"	4'-2"	7'-6"	61.3	#7	6"	3'-4"	9'-4"	12'-8"	103.6	#4	12"	2'-8"	3.6	#4	12"	9'-4"	12.5	96	#4	64.1	32	#4	21.4	20'	8'	3.31	627.2
20'	9'	18"	19"	15"	#9	6"	22'-2"	301.5	#4	6"	22'-2"	59.2	#7	6"	3'-4"	4'-2"	7'-6"	61.3	#7	6"	3'-4"	10'-4"	13'-8"	111.7	#4	12"	2'-8"	3.6	#4	12"	10'-4"	13.8	96	#4	64.1	36	#4	24.0	20'	9'	3.40	639.2
20'	10'	18"	19"	15"	#9	6"	22'-2"	301.5	#4	6"	22'-2"	59.2	#7	6"	3'-4"	4'-2"	7'-6"	61.3	#7	6"	3'-4"	11'-4"	14'-8"	119.9	#4	12"	2'-8"	3.6	#4	12"	11'-4"	15.1	96	#4	64.1	40	#4	26.7	20'	10'	3.50	651.4
20'	11'	18"	19"	15"	#9	6"	22'-2"	301.5	#4	6"	22'-2"	59.2	#8	6"	3'-4"	4'-7"	7'-11"	84.6	#8	6"	3'-4"	12'-4"	15'-8"	167.3	#4	12"	2'-8"	3.6	#4	12"	12'-4"	16.5	96	#4	64.1	44	#4	29.4	20'	11'	3.59	726.2
20'	12'	18"	19"	15"	#9	6"	22'-2"	301.5	#4	6"	22'-2"	59.2	#8	6"	3'-4"	4'-7"	7'-11"	84.6	#8	6"	3'-4"	13'-4"	16'-8"	178.0	#4	12"	2'-8"	3.6	#4	12"	13'-4"	17.8	96	#4	64.1	48	#4	32.1	20'	12'	3.68	740.9
20'	15'	18"	19"	15"	#9	6"	22'-2"	301.5	#4	6"	22'-2"	59.2	#8	6"	3'-7"	5'-1"	8'-8"	92.6	#8	6"	3'-7"	16'-4"	19'-11"	212.7	#6	12"	3'-5"	10.3	#6	12"	16'-4"	49.1	96	#4	64.1	60	#4	40.1	20'	15'	3.96	829.6
20'	17'	18"	19"	17"	#9	6"	22'-6"	306.0	#4	6"	22'-6"	60.1	#8	6"	4'-0"	5'-1"	9'-1"	97.0	#8	6"	4'-0"	18'-4"	22'-4"	238.5	#7	12"	3'-10"	15.7	#7	12"	18'-4"	74.9	96	#4	64.1	68	#4	45.4	20'	17'	4.39	901.7

DESIGN DATA:

- DESIGNED IN ACCORDANCE WITH 2007 AASHTO LRFD BRIDGE DESIGN SPECIFICATIONS AND INTERIM SPECIFICATIONS FROM 2008.
- DESIGNED FOR HL-93 LOADING AND ODOT OVERLOAD TRUCK.
- MATERIALS:
 CONCRETE (CLASS AA) $f'_c = 4$ KSI
 REINFORCING STEEL $f_y = 60$ KSI

GENERAL NOTES:

- ALL CONSTRUCTION AND MATERIAL REQUIREMENTS SHALL BE IN ACCORDANCE WITH THE 2009 OKLAHOMA STANDARD SPECIFICATIONS FOR HIGHWAY CONSTRUCTION.
- ALL CONCRETE EDGES SHALL HAVE A $1\frac{1}{2}$ " CHAMFER UNLESS OTHERWISE SHOWN OR NOTED. ALL CHAMFER STRIPS SHALL BE SIZED LUMBER.
- ALL REINFORCING STEEL SHALL HAVE A 2" MINIMUM CLEAR COVER UNLESS OTHERWISE SHOWN.
- THE QUANTITY FOR REINFORCING STEEL DOES NOT INCLUDE LAP SPLICES OF E1-BARS OR E2-BARS IN THE LENGTH OF THE BARREL OR AT TRANSVERSE CONSTRUCTION JOINTS. THE SPLICE LENGTH FOR E-BARS SHALL BE 24" MINIMUM. THE NUMBER OF SPLICES USED IS TO BE APPROVED BY THE ENGINEER. REINFORCING STEEL FOR SPLICES SHALL NOT BE MEASURED FOR PAYMENT, AND ALL COSTS WILL BE INCLUDED IN THE UNIT BID PRICE FOR REINFORCING STEEL.
- TRANSVERSE CONSTRUCTION JOINTS SHALL BE PLACED IN ALL CULVERTS 100 FT. OR MORE IN LENGTH. JOINTS SHALL BE SPACED AT 60 FT. MAX.
- REINFORCING STEEL SHALL BE CONTINUOUS THROUGH THE TRANSVERSE CONSTRUCTION JOINT AND EXTEND A MIN. OF 24" INTO ADJACENT SECTION.

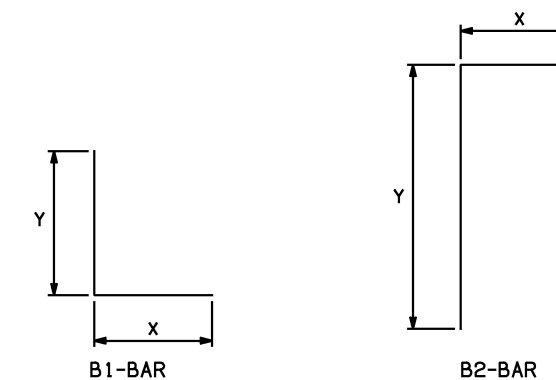

BAR BEND DIAGRAMS

NOTE: ALL *X* DIMENSIONS ARE HORIZONTAL IN BARREL SECTION.
 ALL *Y* DIMENSIONS ARE VERTICAL IN BARREL SECTION.

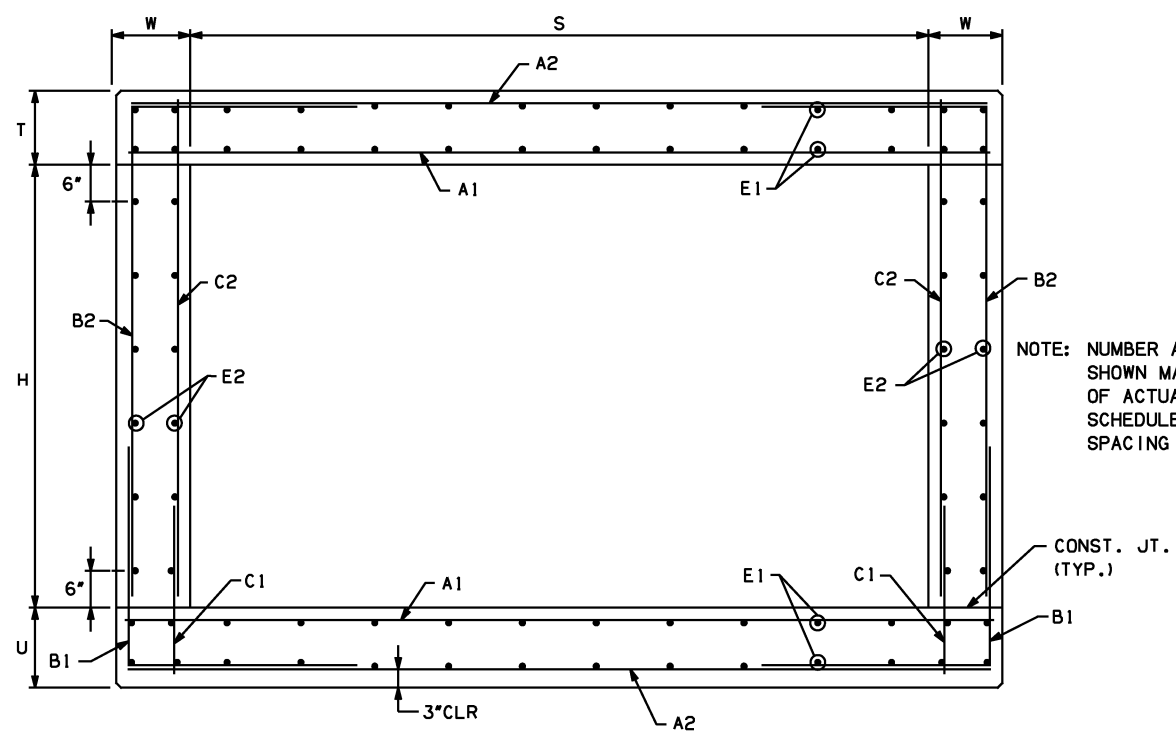

BARREL SECTION

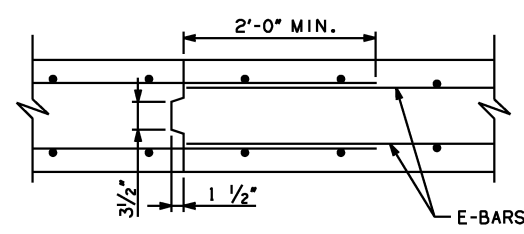

TRANSV. CONSTR. JOINT

BASIS OF PAYMENT		
ITEM NO.	ITEM	UNIT
509.06 (A)	CLASS AA CONCRETE	C.Y.
511.06 (A)	REINFORCING STEEL	LB.

APPROVED BY BRIDGE ENGINEER *Scott A. Smith* DATE 4/2/10

OKLAHOMA DEPT. OF TRANSPORTATION
BRIDGE STANDARD (ENGLISH)
 RCB CULVERTS - BARREL DETAILS
 20'-0" SPAN - SINGLE CELL
 2 FT. TO 10 FT. FILL

2009 SPECIFICATIONS	RCB-C1-20(2-10)	01E
---------------------	-----------------	-----

B-522E