

SECTION C1 AND C2

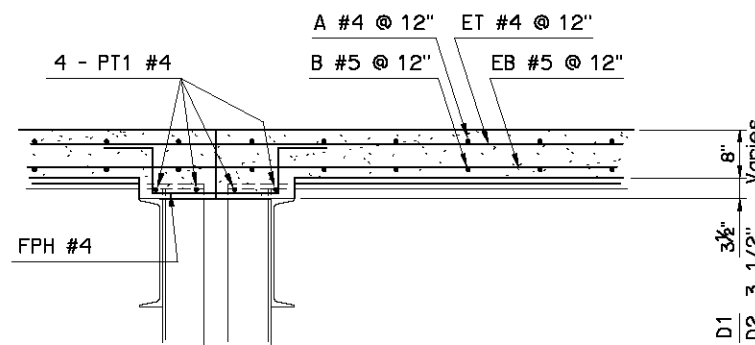

SECTION D1 AND D2

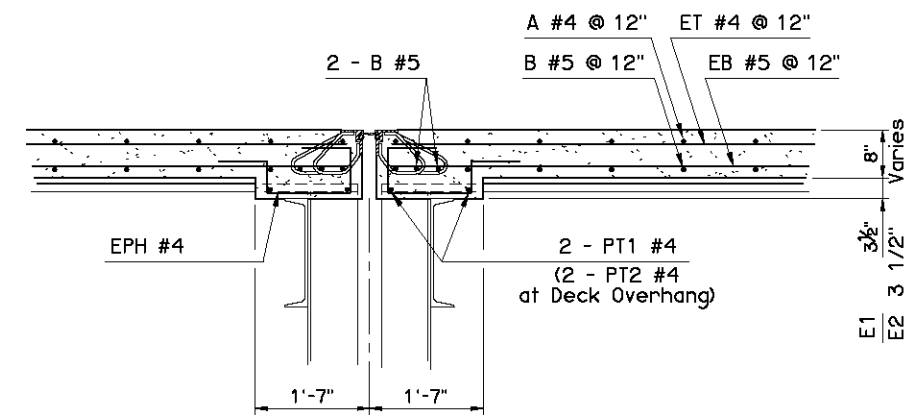

SECTION E1 AND E2

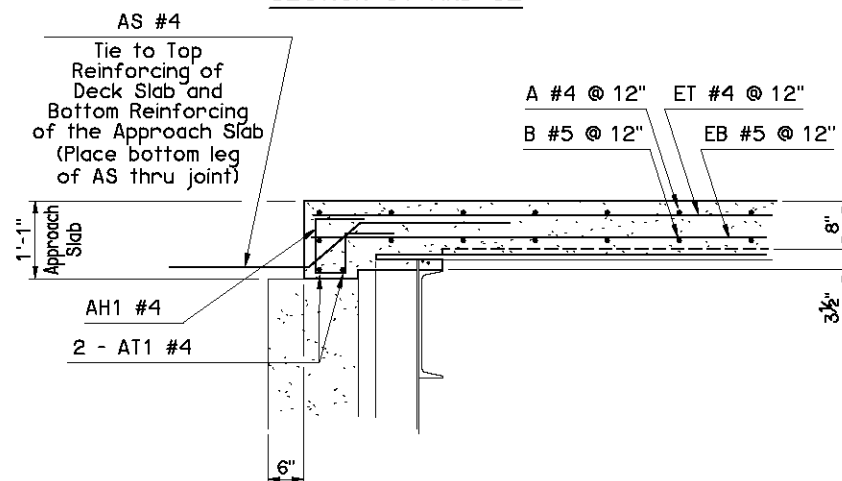

SECTION B

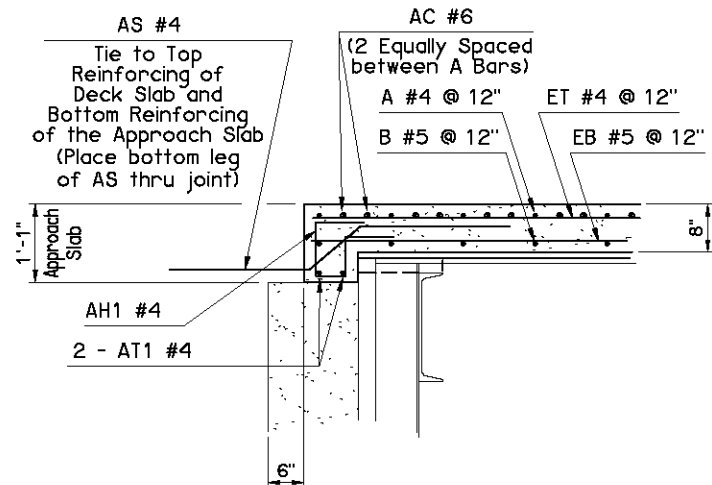

SECTION A

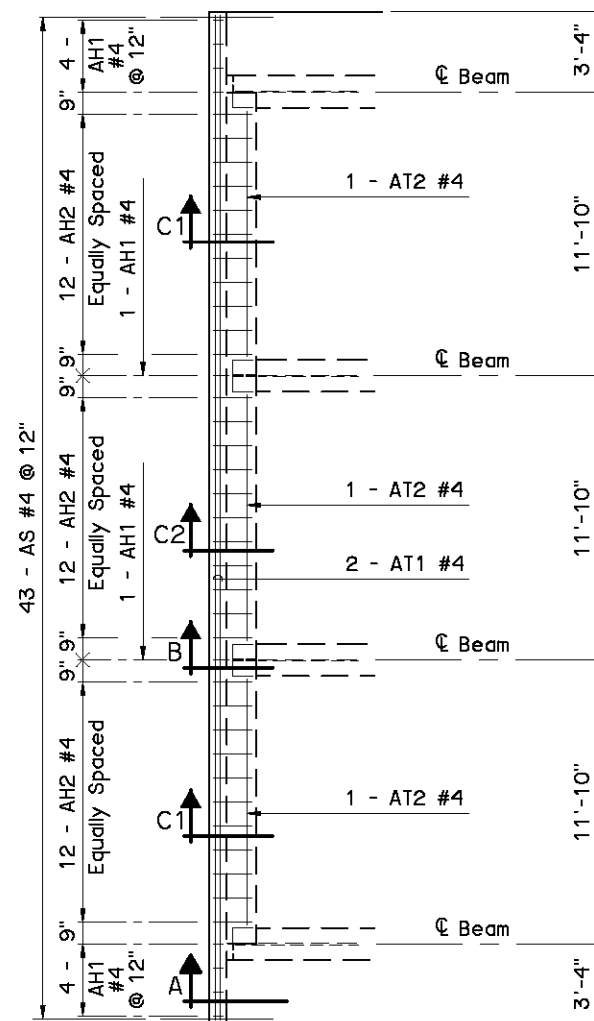

ABUTMENT

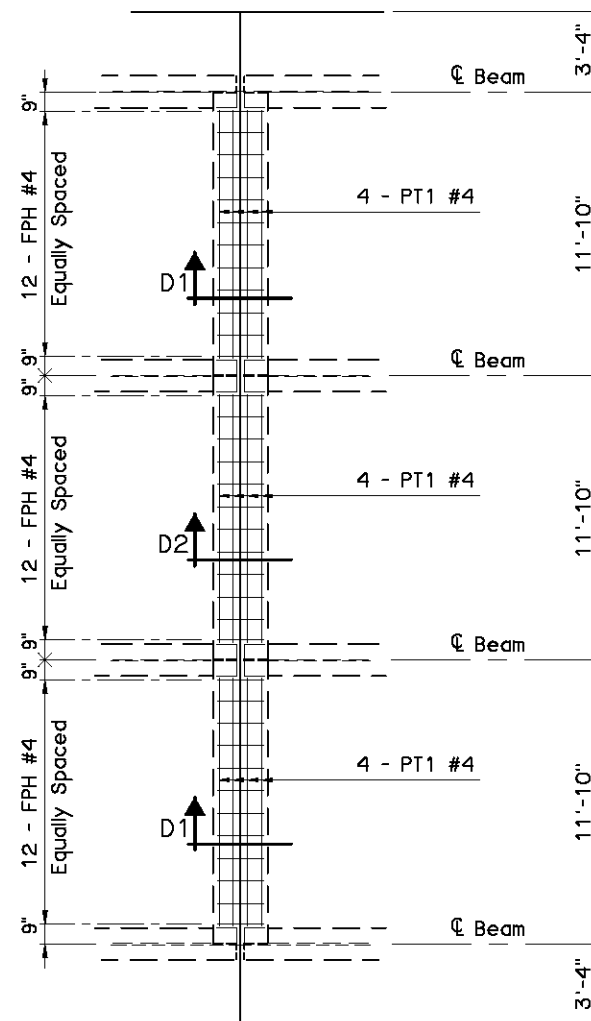

FIXED PIER

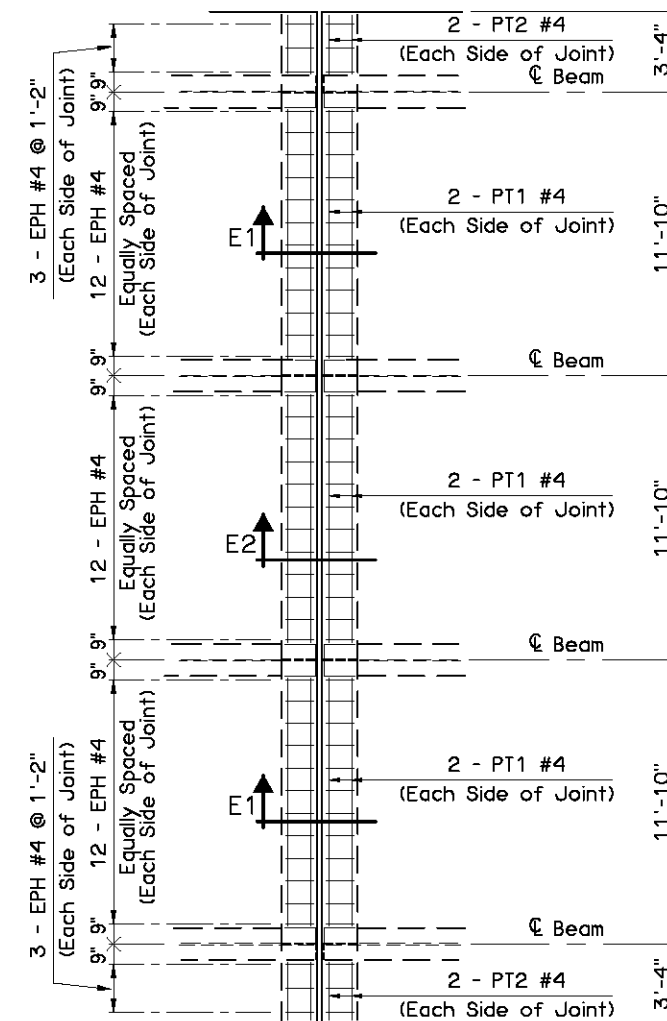

EXPANSION PIER

NOTE:
Deck Slab reinforcing
not shown for clarity.

DIAPHRAGM REINFORCING PLANS

APPROVED BY BRIDGE ENGINEER *Scott J. Smith* DATE *4/2/10*

OKLAHOMA DEPT. OF TRANSPORTATION
BRIDGE STANDARD (ENGLISH)
DIAPHRAGM DETAILS
ROLLED BEAMS
CONVENTIONAL (SHEET 2 OF 2)

2009 SPECIFICATIONS | B40-C-DIA-RB-2 | 02E | B-377E