

**EMBEDDED BEAM PLATE DETAILS**

NOTE:  
Provide an Embedded Beam Plate at expansion ends only.

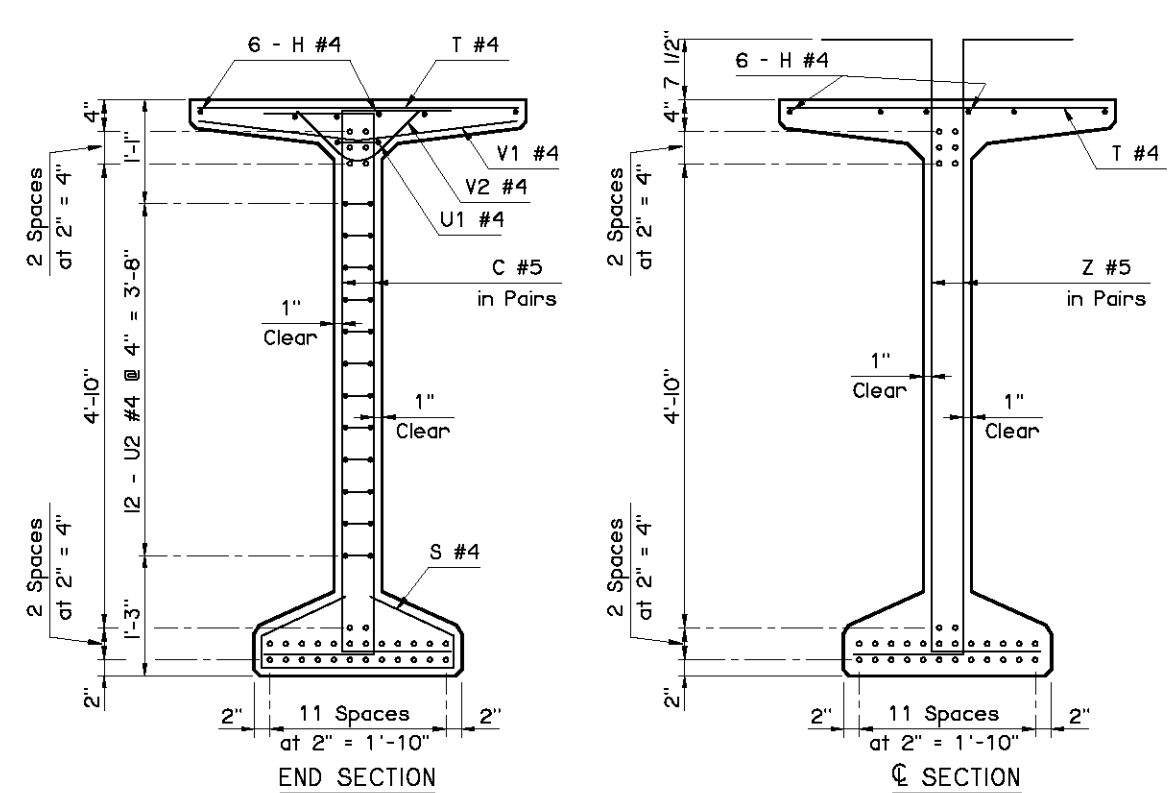

**BEAM SECTIONS**  
(32 - 0.6" STRANDS)

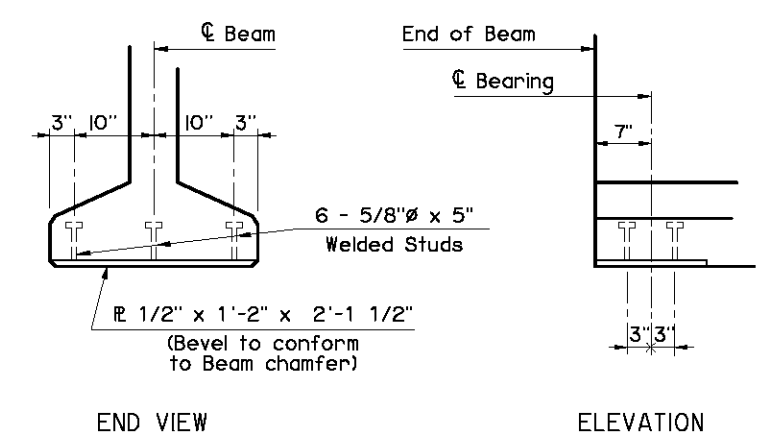

**EMBEDDED SOLE PLATE DETAILS**

NOTE:  
Provide an Embedded Sole Plate at each end of the Beam.

APPROVED BY BRIDGE ENGINEER *Scott J. Smith* DATE 4/2/10

OKLAHOMA DEPT. OF TRANSPORTATION  
BRIDGE STANDARD (ENGLISH)  
**TYPE BT-72 P.C. BEAM DETAILS**  
100' SPAN  
**CONVENTIONAL (SHEET 2 OF 2)**

2009 SPECIFICATIONS B40-C-PCB-BT-100-2 01E  
B-319E