

ABUTMENT FIXED BEARING DETAILS

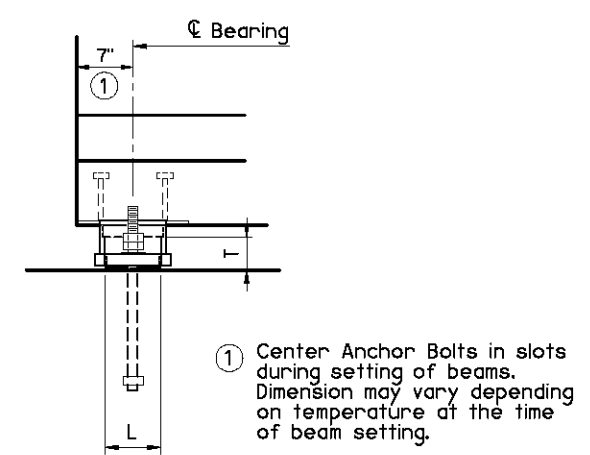
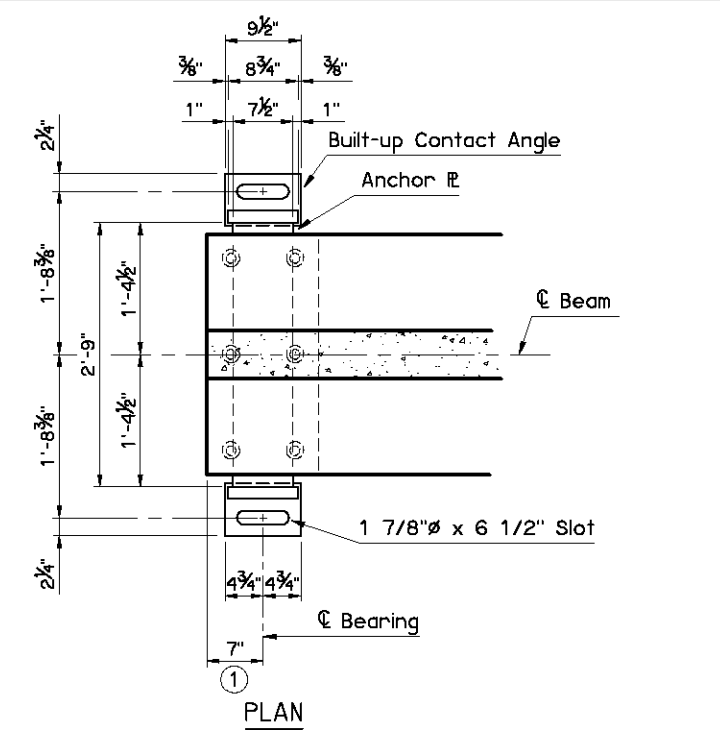
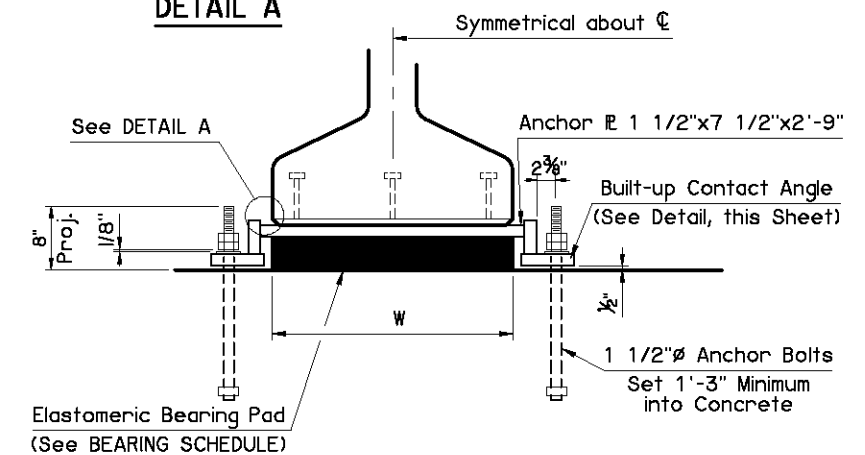
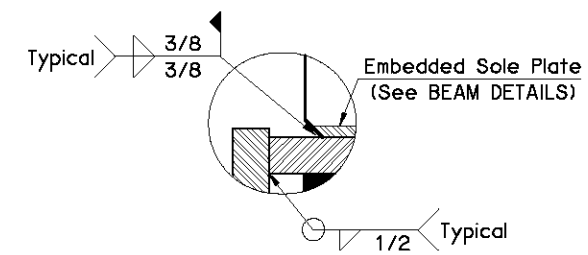
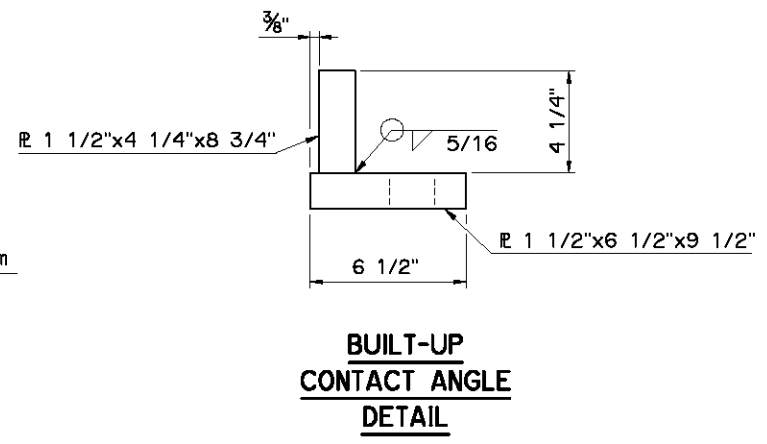

PIER EXPANSION BEARING DETAILS

EXPANSION BEARING ASSEMBLY NOTES:
 Provide structural steel for Anchor Plates and Built-up Contact Angles in accordance with ASTM A240 (Austenitic Stainless Steel, Type 316, Charpy V-Notch testing not required). For Anchor Bolts, provide continuously threaded bars in accordance with ASTM A320, Class 2, Grade B8M (Austenitic Stainless Steel, Type 316, Charpy V-Notch testing not required). Use austenitic stainless steel nuts and washers conforming to ASTM A194, Grade 8M and ASTM A320, respectively. Perform all welding consistent with procedures for stainless steel.

FIXED BEARING ASSEMBLY NOTES:
 Provide structural steel for Anchor Plates in accordance with AASHTO M270 (ASTM A709), Grade 50W (Weathering Steel, Charpy V-Notch testing not required). For Anchor Bars, provide a reinforcing bar in accordance with AASHTO M31, Grade 60.

SPAN	60 DUROMETER ELASTOMERIC BEARING PAD				MAXIMUM EXPANSION LENGTH ②
	SIZE (T x L x W)	COVER LAYER	INNER LAYER	LAMINATE PLATE	
95'	4 1/8"x6"x2'-6"	2 - 1/4"	7 - 3/8"	8 - 1/8"	255'
100'	4 1/8"x6"x2'-6"	2 - 1/4"	7 - 3/8"	8 - 1/8"	255'
105'	4 1/8"x6 1/2"x2'-6"	2 - 1/4"	7 - 3/8"	8 - 1/8"	255'
110'	4 1/8"x6 1/2"x2'-6"	2 - 1/4"	7 - 3/8"	8 - 1/8"	260'
115'	4 1/8"x6 1/2"x2'-6"	2 - 1/4"	7 - 3/8"	8 - 1/8"	260'
120'	4 1/8"x6 1/2"x2'-6"	2 - 1/4"	7 - 3/8"	8 - 1/8"	260'
125'	4 1/8"x6 1/2"x2'-6"	2 - 1/4"	7 - 3/8"	8 - 1/8"	265'
130'	4 1/8"x7"x2'-6"	2 - 1/4"	7 - 3/8"	8 - 1/8"	265'

② Bonding to Anchor Plate not required.

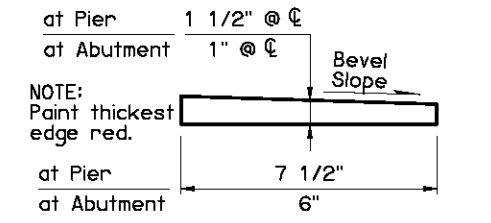

NOTE:
 Beveled Anchor Plate is required when angle between beam supports due to roadway grade exceeds 1%. Bevel Slope to match angle between beam supports and horizontal.

APPROVED BY BRIDGE ENGINEER *Scott J. Smith* DATE *4/2/10*

OKLAHOMA DEPT. OF TRANSPORTATION
 BRIDGE STANDARD (ENGLISH)
BEARING DETAILS
 TYPE J.P.C. BEAMS
 INTEGRAL

2009 SPECIFICATIONS | B40-I-BRG-PCJ | 02E | B-198E