

Deck Slab shown for informational purposes only.
Do not place Deck Slab Concrete until the
Abutment Diaphragm Concrete has attained
a compressive strength of 3000 p.s.i.

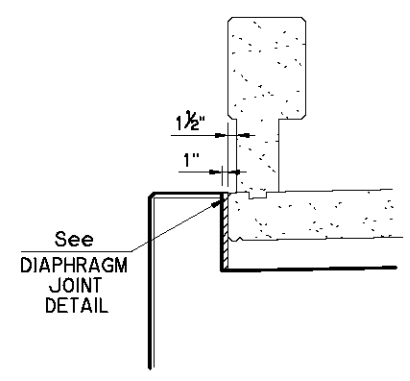

SECTION D

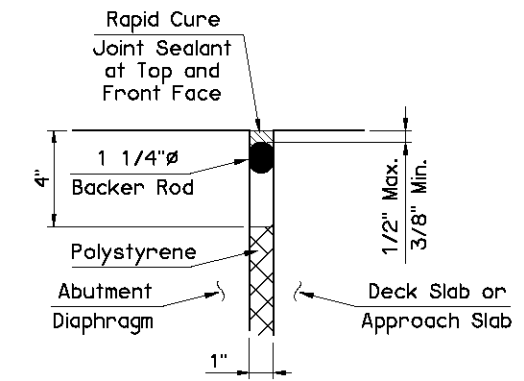

DIAPHRAGM JOINT DETAIL

NOTE:
Include all costs to install the
Diaphragm Joint in other items
of work.

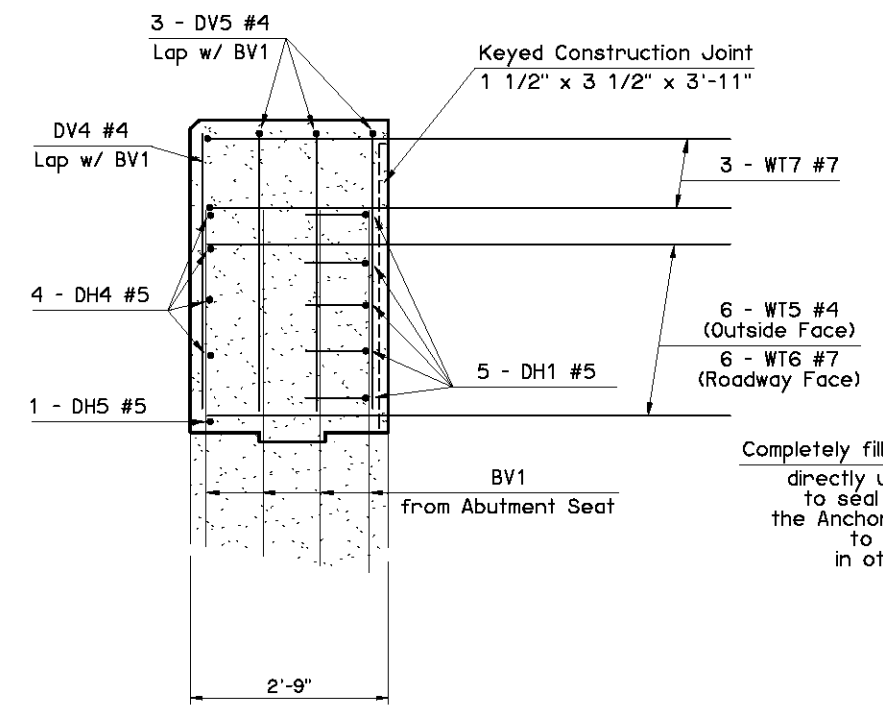

SECTION C-C

Completely fill void in Abutment Diaphragm
directly under beam with silicone
to seal the exposed edge of
the Anchor Plate. Include all costs
to install the silicone
in other items of work.

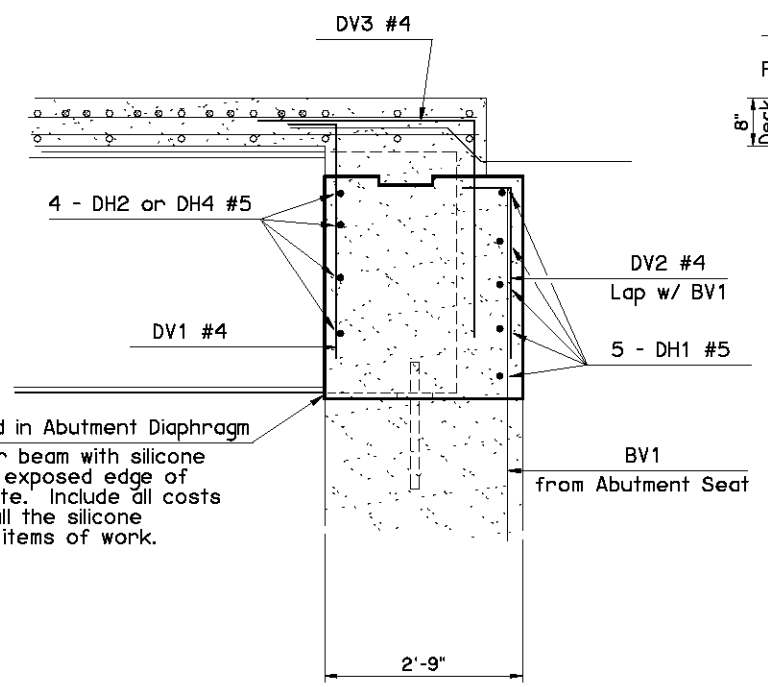

SECTION B-B

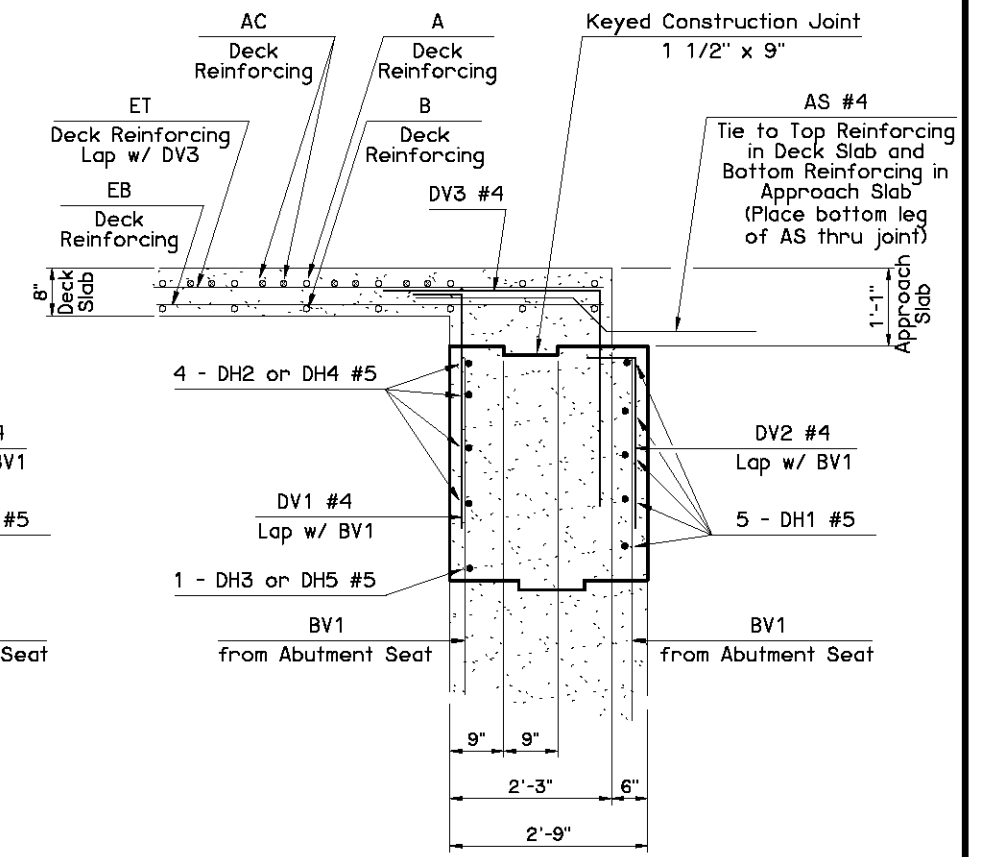

SECTION A-A

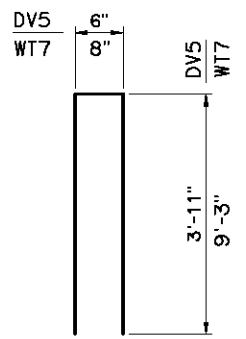

DV5 #4 x 8'-4"
WT7 #7 x 19'-2"

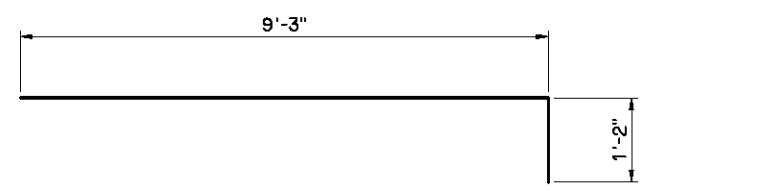

WT6 #7 x 10'-5"

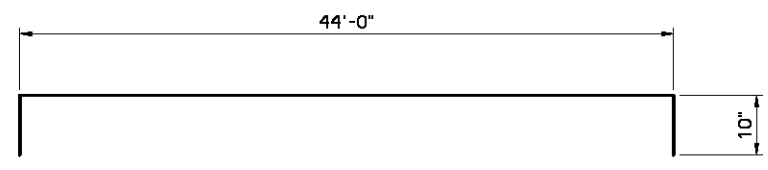

DH1 #5 x 45'-8"

ABUTMENT DIAPHRAGM BAR LIST ONE SHOWN				
EPOXY COATED REINFORCING				
MARK	SIZE	NO.	FORM	LENGTH
DV1	#4	47	BNT.	4'-0"
DV2	#4	42	BNT.	3'-0"
DV3	#4	43	BNT.	6'-0"
DV4	#4	4	STR.	3'-11"
DV5	#4	6	BNT.	8'-4"
DH1	#5	5	BNT.	45'-8"
DH2	#5	12	STR.	11'-6"
DH3	#5	3	STR.	7'-6"
DH4	#5	8	STR.	4'-1"
DH5	#5	2	STR.	2'-1"
WT5	#4	12	STR.	5'-9"
WT6	#7	12	BNT.	10'-5"
WT7	#7	6	BNT.	19'-2"

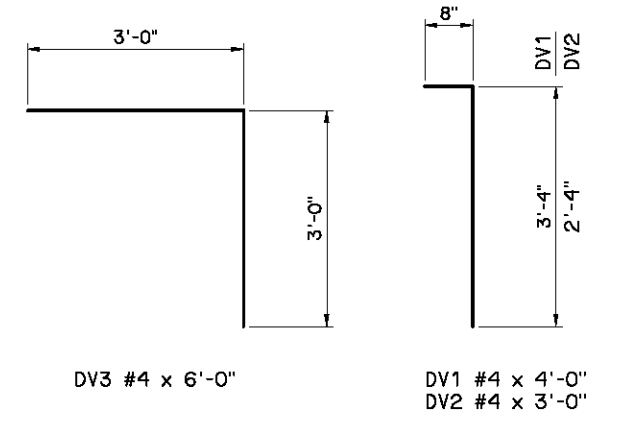

DV3 #4 x 6'-0"

DV1 #4 x 4'-0"
DV2 #4 x 3'-0"

APPROVED BY BRIDGE ENGINEER *Scott J. Smith* DATE *4/2/10*

OKLAHOMA DEPT. OF TRANSPORTATION
BRIDGE STANDARD (ENGLISH)
ABUTMENT DIAPHRAGM DETAILS
55' THRU 100' ROLLED BEAM SPANS
INTEGRAL (SHEET 2 OF 2)

2009 SPECIFICATIONS B40-I-ADIA-RB-55100-2 02E B-182E