

Deck Slab shown for informational purposes only.  
Do not place Deck Slab Concrete until the  
Abutment Diaphragm Concrete has attained  
a compressive strength of 3000 p.s.i.

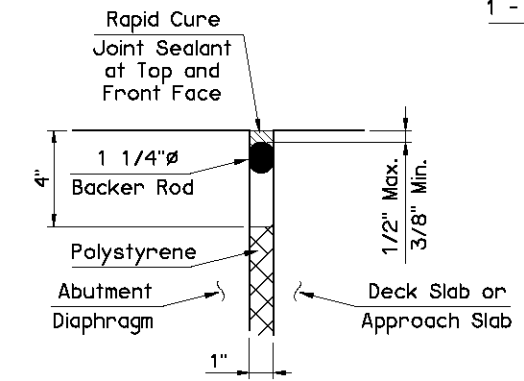

NOTE:  
Include all costs to install the  
Diaphragm Joint in other items  
of work.

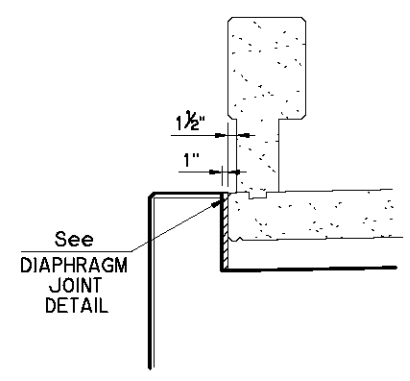
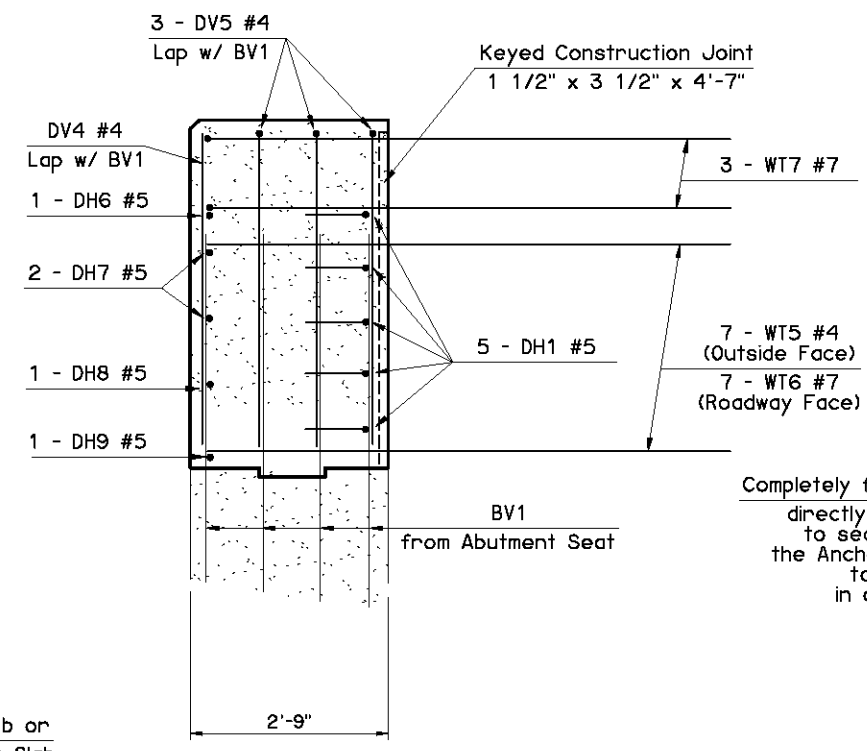

SECTION C-C

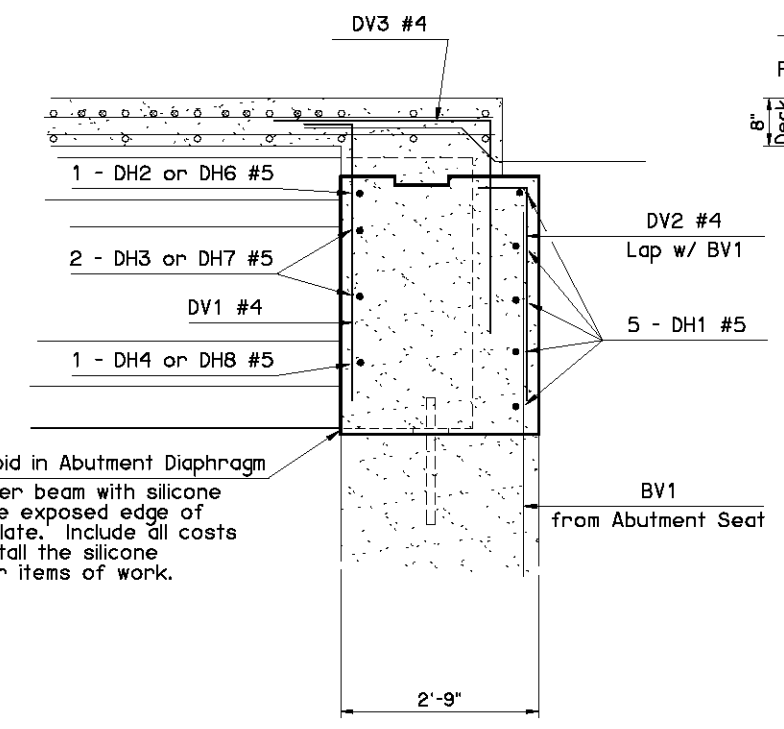

SECTION B-B

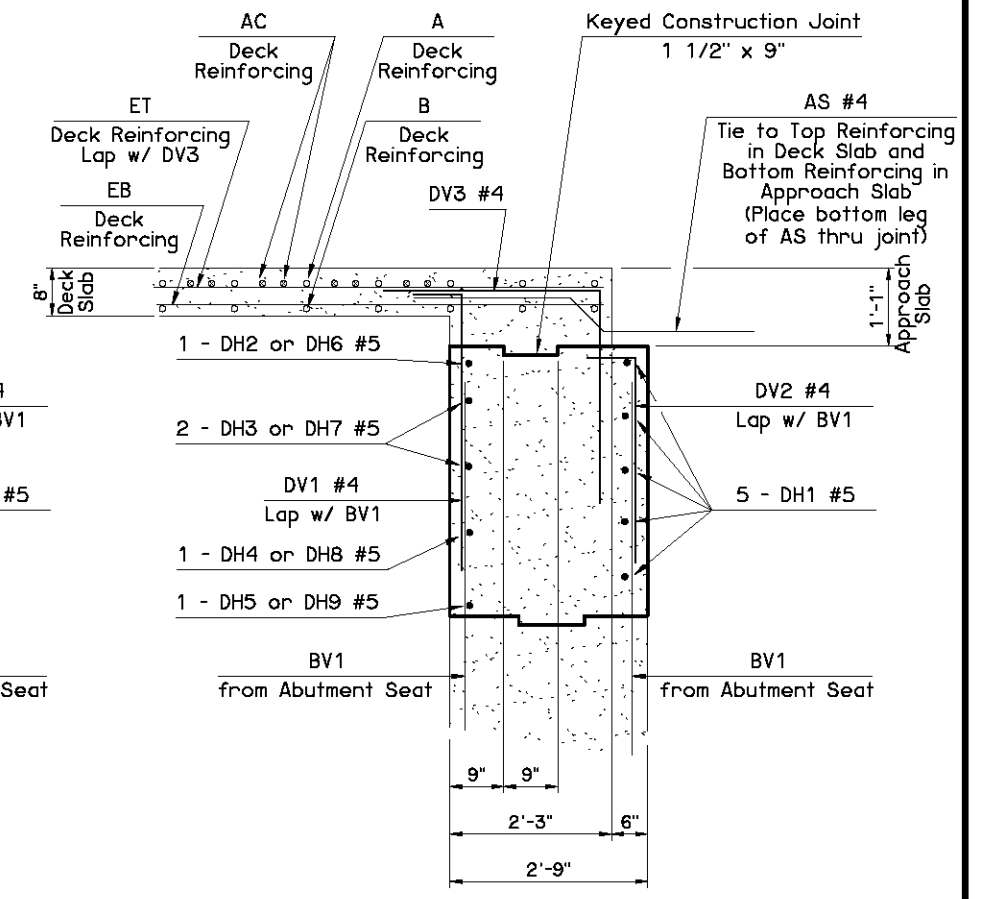

SECTION A-A

Completely fill void in Abutment Diaphragm  
directly under beam with silicone  
to seal the exposed edge of  
the Anchor Plate. Include all costs  
to install the silicone  
in other items of work.

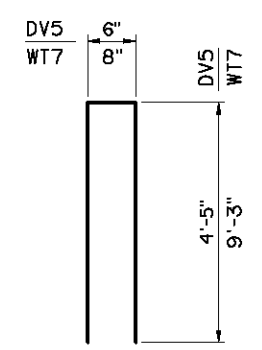

DV5 #4 x 9'-4"  
WT7 #7 x 19'-2"

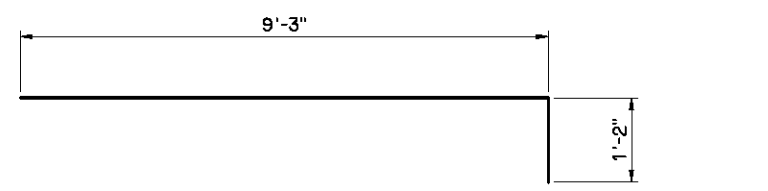

WT6 #7 x 10'-5"

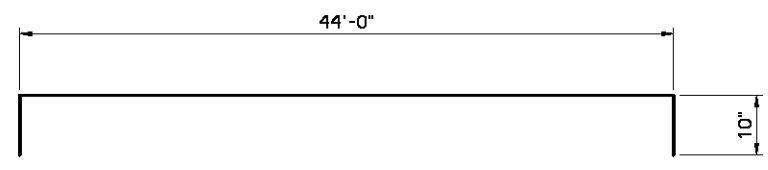

DH1 #5 x 45'-8"

ABUTMENT DIAPHRAGM BAR LIST ONE SHOWN				
EPOXY COATED REINFORCING				
MARK	SIZE	NO.	FORM	LENGTH
DV1	#4	44	BNT.	4'-6"
DV2	#4	42	BNT.	3'-6"
DV3	#4	43	BNT.	6'-0"
DV4	#4	4	STR.	4'-5"
DV5	#4	6	BNT.	9'-4"
DH1	#5	5	BNT.	45'-8"
DH2	#5	3	STR.	9'-8"
DH3	#5	6	STR.	10'-5"
DH4	#5	3	STR.	9'-2"
DH5	#5	3	STR.	7'-0"
DH6	#5	2	STR.	4'-2"
DH7	#5	4	STR.	4'-6"
DH8	#5	2	STR.	3'-11"
DH9	#5	2	STR.	2'-10"
WT5	#4	14	STR.	5'-9"
WT6	#7	14	BNT.	10'-5"
WT7	#7	6	BNT.	19'-2"

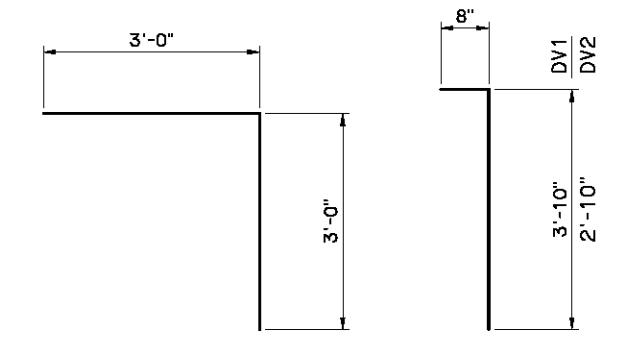

DV3 #4 x 6'-0"

DV1 #4 x 4'-6"  
DV2 #4 x 3'-6"

APPROVED BY BRIDGE ENGINEER *Scott J. Smith* DATE *4/2/10*

OKLAHOMA DEPT. OF TRANSPORTATION  
BRIDGE STANDARD (ENGLISH)  
**ABUTMENT DIAPHRAGM DETAILS**  
TYPE III AND TYPE C P.C. BEAMS  
INTEGRAL (SHEET 2 OF 2)

2009 SPECIFICATIONS | B40-I-ADIA-PC3-2 | 02E | B-174E