

INTENTIONALLY ROUGHENED SURFACE DETAILS

Intentionally roughen the entire top surface of P.C. Beam to a minimum height of 1/4" over a maximum pitch of 2" measured longitudinally along the length of the beam. Provide a crest and trough associated with the height of not less than 1/2". Produce the roughened surface by using a special trowel to form one of the surfaces shown in the details, by cleaning the concrete surface with a stiff wire brush (or blasting) to expose the aggregate to a height of 1/4", or by using another approved method. Submit the method to be used for approval by the Engineer. Repair any damage to reinforcement's epoxy coating before placement of deck concrete.

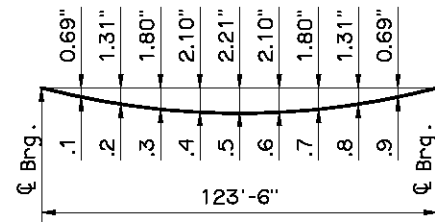

DEAD LOAD DEFLECTION DIAGRAM

NOTE:
The Dead Load Deflection shown above at the tenth points are the initial deflections due to Deck Slab + Diaphragms + Haunch + S.I.P. Steel Deck Form Allowance + Concrete Traffic Rail. It does not include the Beam weight or Future Wearing Surface.

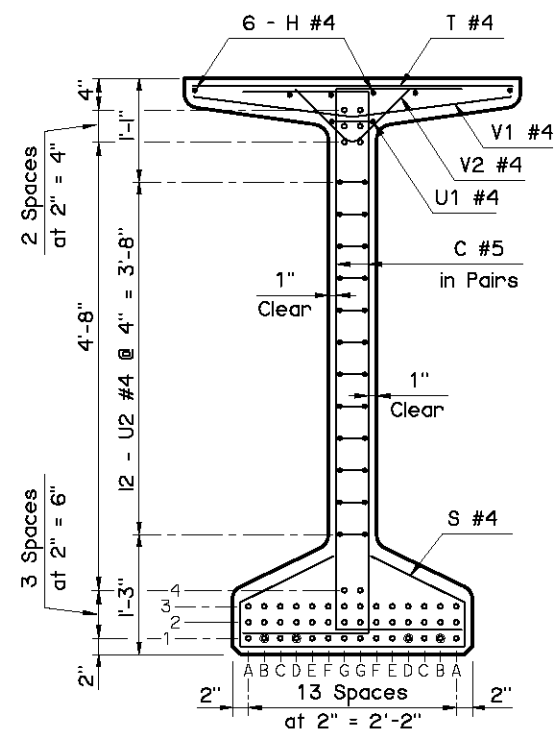
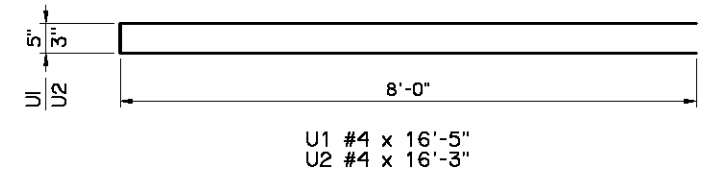
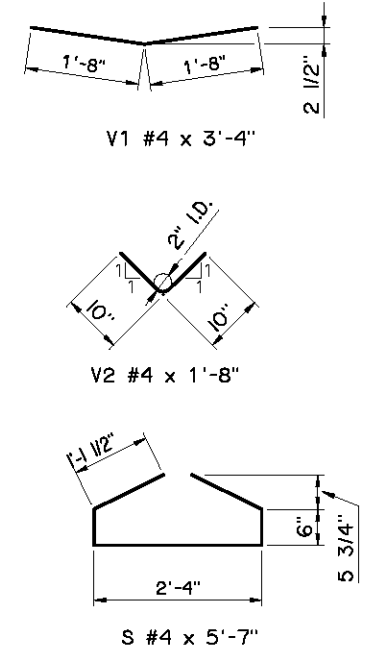
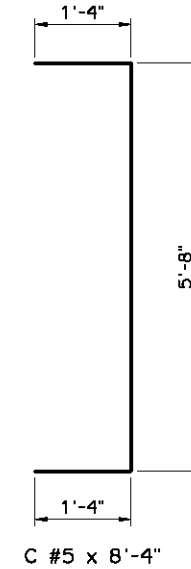
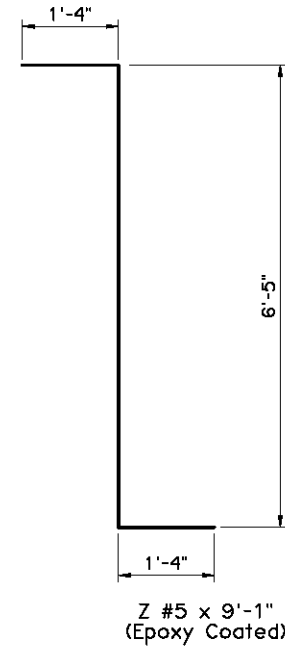

END SECTION

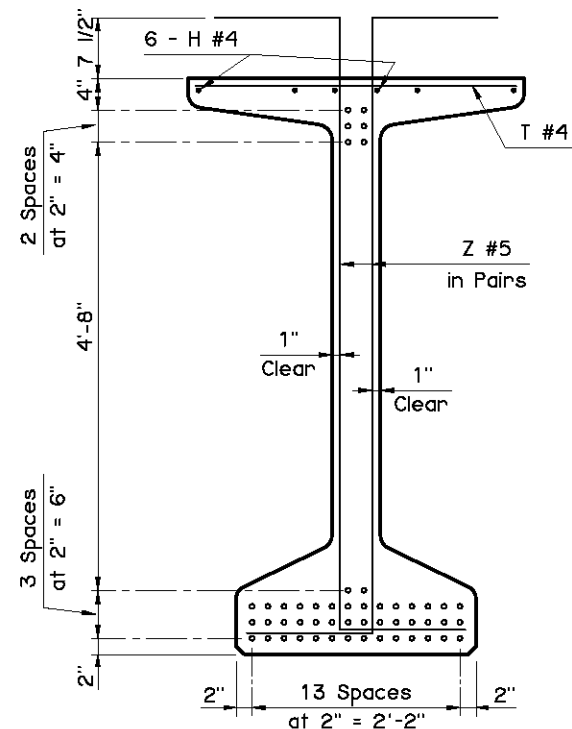

BEAM SECTIONS
(50 - 0.6" STRANDS)

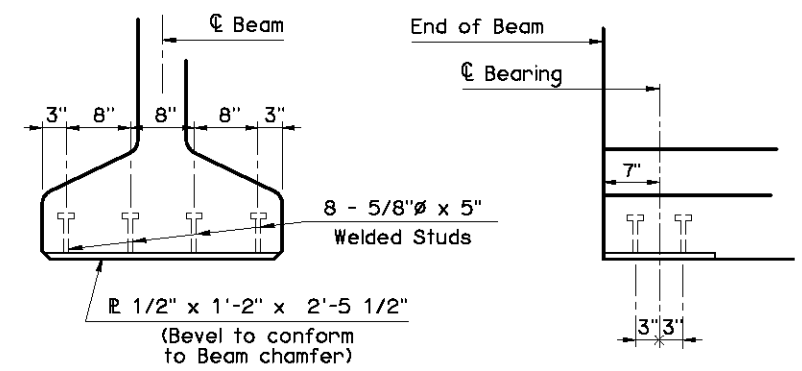

EMBEDDED SOLE PLATE DETAILS

NOTE:
Provide an Embedded Sole Plate at each end of the Beam.

DEBOND SCHEDULE	
DEBOND PAIR	DEBOND LENGTH FROM END OF BEAM
B1	12'-0"
D1	6'-0"

APPROVED BY BRIDGE ENGINEER *Scott J. Smith* DATE *4/2/10*

OKLAHOMA DEPT. OF TRANSPORTATION
BRIDGE STANDARD (ENGLISH)
TYPE J P.C. BEAM DETAILS
125' SPAN
INTEGRAL (SHEET 2 OF 2)

2009 SPECIFICATIONS | B40-I-PCB-J-125-2 | 01E | B-141E