

**INTENTIONALLY ROUGHENED SURFACE DETAILS**

Intentionally roughen the entire top surface of P.C. Beam to a minimum height of 1/4" over a maximum pitch of 2" measured longitudinally along the length of the beam. Provide a crest and trough associated with the height of not less than 1/2". Produce the roughened surface by using a special trowel to form one of the surfaces shown in the details, by cleaning the concrete surface with a stiff wire brush (or blasting) to expose the aggregate to a height of 1/4", or by using another approved method. Submit the method to be used for approval by the Engineer. Repair any damage to reinforcement's epoxy coating before placement of deck concrete.

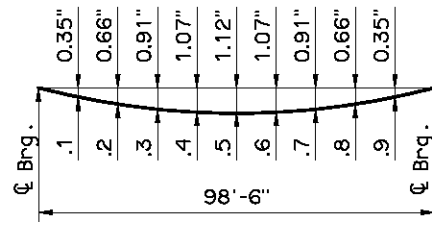

**DEAD LOAD DEFLECTION DIAGRAM**

**NOTE:**  
The Dead Load Deflection shown above at the tenth points are the initial deflections due to Deck Slab + Diaphragms + Haunch + S.I.P. Steel Deck Form Allowance + Concrete Traffic Rail. It does not include the Beam weight or Future Wearing Surface.

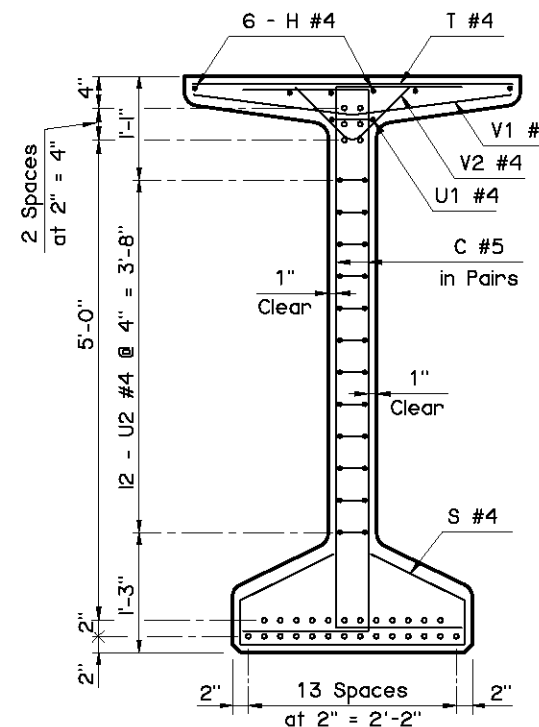
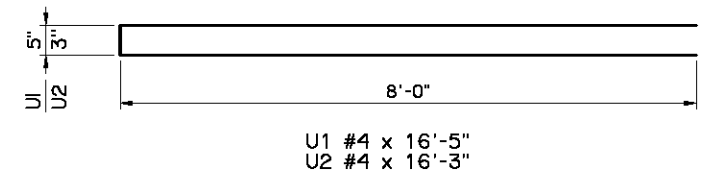
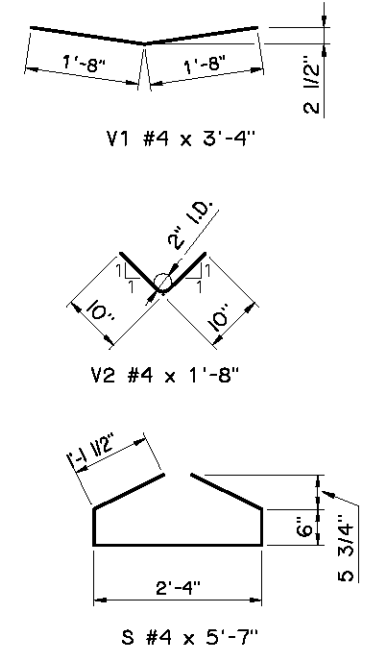
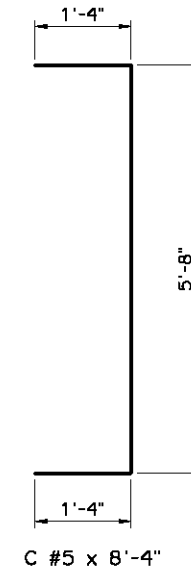
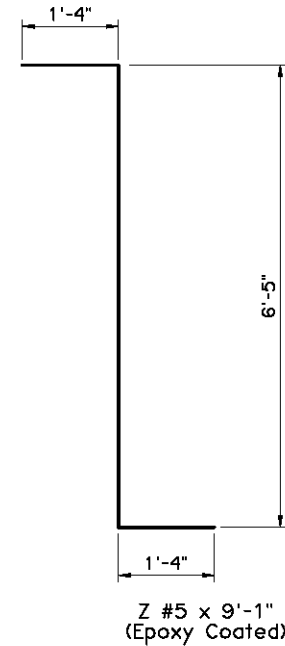

**END SECTION**

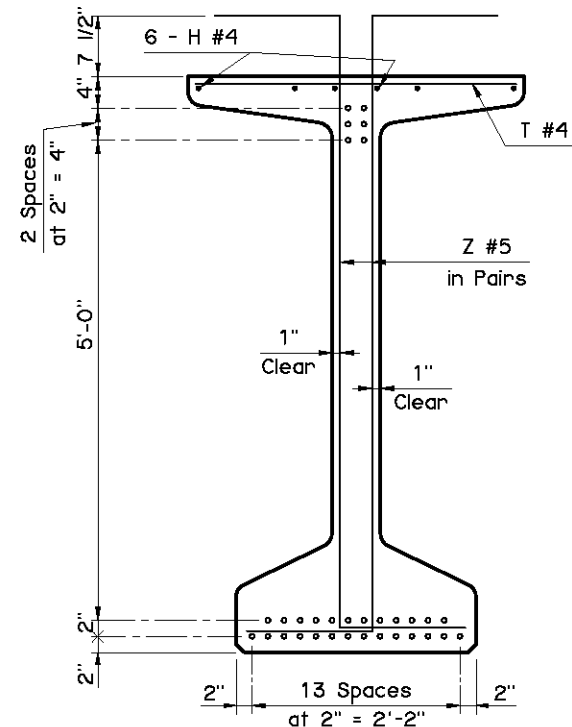

**BEAM SECTIONS**  
(32 - 0.6" STRANDS)

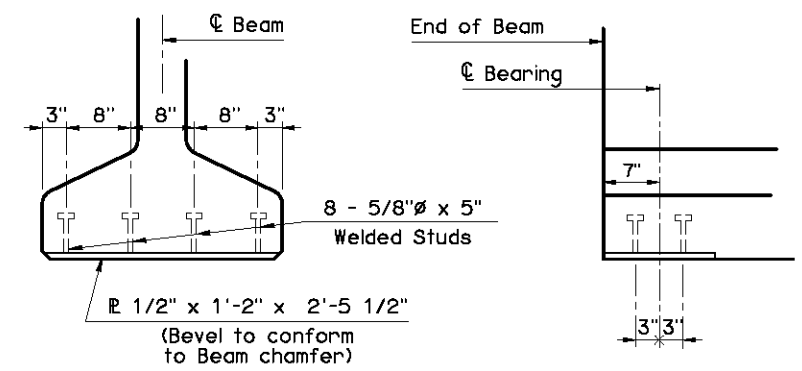

**EMBEDDED SOLE PLATE DETAILS**

**NOTE:**  
Provide an Embedded Sole Plate at each end of the Beam.

APPROVED BY BRIDGE ENGINEER *David J. Smith* DATE *4/2/10*

OKLAHOMA DEPT. OF TRANSPORTATION  
BRIDGE STANDARD (ENGLISH)  
**TYPE J P.C. BEAM DETAILS**  
100' SPAN  
**INTEGRAL (SHEET 2 OF 2)**

2009 SPECIFICATIONS | B40-I-PCB-J-100-2 | 01E | B-131E