

END VIEW
(Type III P.C.B.)

① Provide Elastomeric Pad with a 50 durometer hardness and consisting of a single layer 5/8" thick x 1'-4" wide x 3'-10 1/2" long. Extend pad 1/2" beyond the end of the beam as shown.

PRESTRESSED CONCRETE BEAM NOTES

COMPRESSIVE STRENGTH
Provide concrete with a compressive strength of 4,500 p.s.i. at transfer of prestress and 6,000 p.s.i. at 28 days.

STRAND TYPE
Provide low-relaxation strands having a nominal diameter of 0.6" with ultimate tensile strength of 270 k.s.i.

LFD OPERATING RATING - HS 38.6
The Operating Rating shown is based on a nominal strength using only strands that are bonded for the full length of the beam. All partially bonded strands are neglected in strength computations.

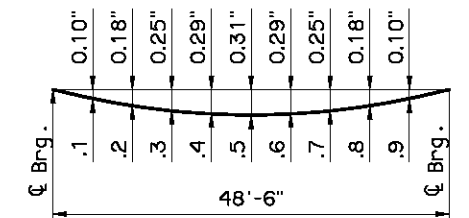

DEAD LOAD DEFLECTION DIAGRAM

NOTE:
The Dead Load Deflection shown above at the tenth points are the initial deflections due to Deck Slab + Diaphragms + Haunch + S.I.P. Steel Deck Form Allowance + Concrete Traffic Rail. It does not include the Beam weight or Future Wearing Surface.

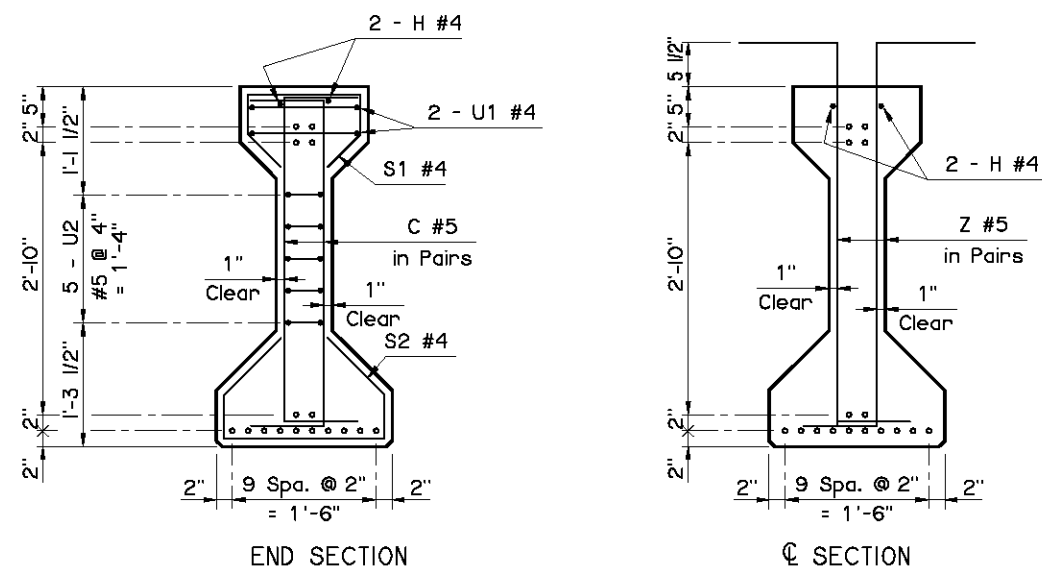

BEAM SECTIONS
(16 - 0.6" STRANDS)

Information shown on this sheet is applicable only to the standard bridge cross-section with 40' Clear Roadway, 8" Deck Slab and 4 Beams at 11'-4" spacing. Any deviation requires custom design and details with an appropriate Dead Load Deflection Diagram.

APPROVED BY BRIDGE ENGINEER *Scott J. Smith* DATE *4/2/10*

OKLAHOMA DEPT. OF TRANSPORTATION
BRIDGE STANDARD (ENGLISH)
TYPE III P.C. BEAM DETAILS
50' SPAN
INTEGRAL

2009 SPECIFICATIONS | B40-I-PCB-III-50 | 02E
B-90E