

EXISTING SHEAR CONNECTORS, IF PRESENT, WILL REMAIN

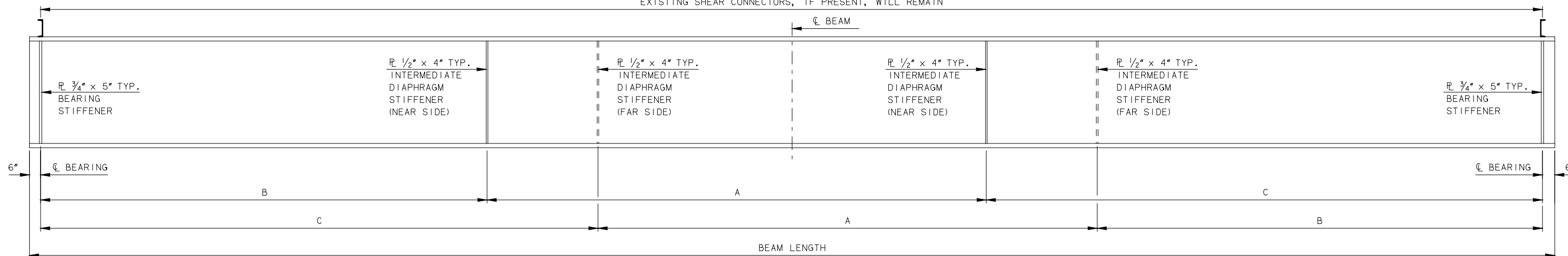

W33x130, W33x141, W36x135, or W36x150

BRIDGE SKEW 30° LEFT FORWARD IS SHOWN IN DRAWING

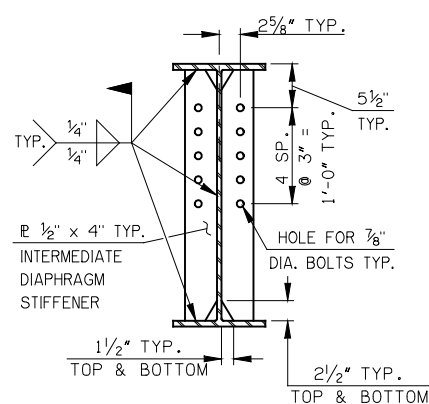

INTERMEDIATE DIAPHRAGM STIFFENER DETAILS

DETAIL SHOWN AT INTERIOR BEAM. OMIT INTERMEDIATE DIAPHRAGM STIFFENERS AT OUTSIDE FACE OF EXTERIOR BEAM.

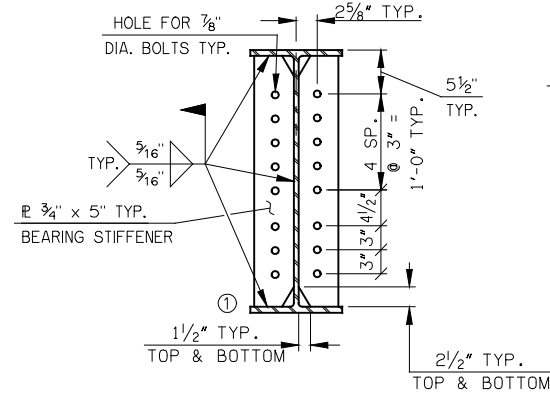

BEARING STIFFENER DETAILS

DETAIL SHOWN AT INTERIOR BEAM. OMIT BOLT HOLES IN BEARING STIFFENERS AT OUTSIDE FACE OF EXTERIOR BEAM. ① MILL TO BEAR AT BOTTOM FLANGE

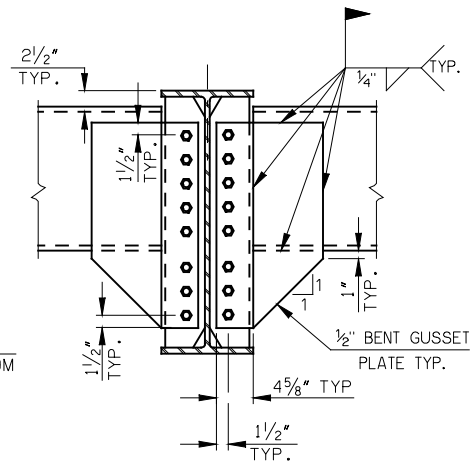

GUSSET DETAILS

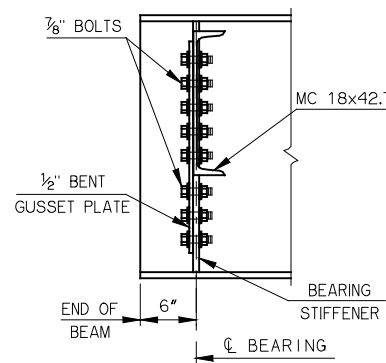

END DIAPHRAGM SECTION

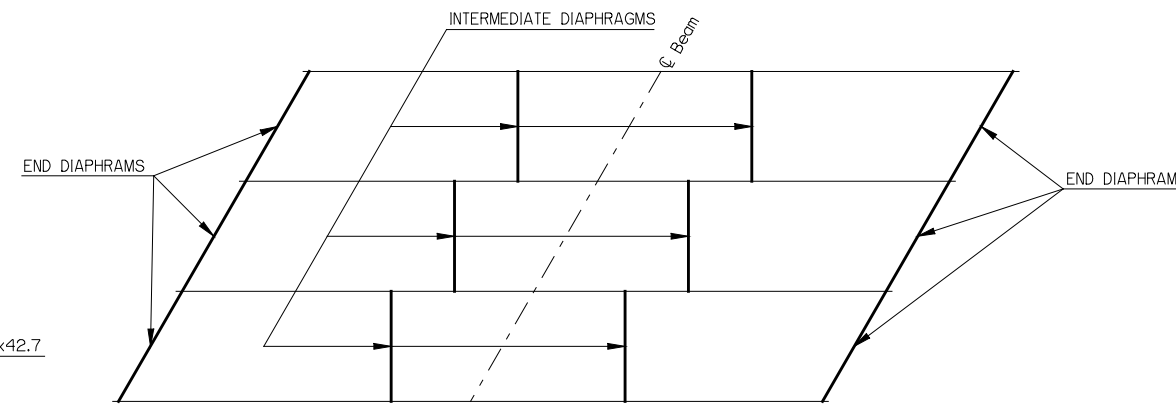

DIAPHRAGM LAYOUT

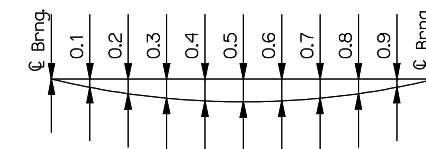

DEAD LOAD DEFLECTION DIAGRAM

NOTES:

- TERMINATE FILLET WELDS 3/8" FROM THE EDGES OF CLIPPED CORNERS AND NON-CLIPPED CORNERS OF STIFFENER PLATES.
- THE LFD OPERATING RATING SHOWN IN THE TABLE APPLIES ONLY TO THE ROLLED BEAMS OF A BRIDGE CONSTRUCTED IN STRICT CONFORMANCE TO ALL RELEVANT DETAILS CONTAINED IN THESE COUNTY BRIDGE STANDARDS AND TO THE ODOT STANDARD SPECIFICATIONS.
- DEAD LOAD DEFLECTIONS SHOWN AT TENTH POINTS ARE THE THEORETICAL BEAM DEFLECTIONS DUE TO A 5 PSF SIP FORMS ALLOWANCE, DECK SLAB, HAUNCH AND CONCRETE TRAFFIC RAIL (TR-3). THE DEAD LOAD DEFLECTIONS SHALL BE ACCOUNTED FOR IN THE HAUNCH DEPTH CALCULATIONS. DEAD LOAD DEFLECTIONS ABOVE ARE BASED UPON THE MAXIMUM SPAN AS SHOWN IN THE TABLES. SHOULD THE BEAMS BE USED FOR SPANS SHORTER THAN THE MAXIMUM SHOWN, DEAD LOAD DEFLECTIONS SHALL BE RECALCULATED AND APPROVED BY THE ENGINEER PRIOR TO SETTING THE HAUNCH DEPTH.
- COMPOSITE SECTION VALUES SHOULD BE USED WHEN SHEAR CONNECTORS ARE PRESENT AT 12" MAXIMUM SPACING. USE NON-COMPOSITE TABLES WHEN BEAMS DO NOT HAVE SHEAR CONNECTORS, OR WHEN THEIR SPACING EXCEEDS 12".
- BOLTS SHALL CONFORM TO AASHTO M 164 (ASTM A 325), TYPE 3. HEX NUTS SHALL CONFORM TO AASHTO M 291 (ASTM A 563), PROPERTY CLASS 8S3 OR 10S3. WASHERS SHALL CONFORM TO AASHTO M 293 (ASTM F 436), TYPE 3.

COMPOSITE SECTION BEAM SCHEDULE - 30° BRIDGE SKEW								
BEAM	MAX. SPAN	BEAM LENGTH	A	30° LEFT FORWARD		30° RIGHT FORWARD		LFD OPERATING RATING
				B	C	B	C	
W33x130	50'-0"	49'-10"	16'-4"	13'-7 1/4"	18'-10 3/4"	18'-10 3/4"	13'-7 1/4"	HS 24.6
W33x141	55'-0"	54'-10"	18'-0"	15'-3 1/4"	20'-6 3/4"	20'-6 3/4"	15'-3 1/4"	HS 22.4
W36x135	55'-0"	54'-10"	18'-0"	15'-3 1/4"	20'-6 3/4"	20'-6 3/4"	15'-3 1/4"	HS 22.2
W36x150	60'-0"	59'-10"	19'-8"	16'-11 1/4"	22'-2 3/4"	22'-2 3/4"	16'-11 1/4"	HS 21.6

NON-COMPOSITE SECTION BEAM SCHEDULE - 30° BRIDGE SKEW								
BEAM	MAX. SPAN	BEAM LENGTH	A	30° LEFT FORWARD		30° RIGHT FORWARD		LFD OPERATING RATING
				B	C	B	C	
W33x130	35'-0"	34'-10"	11'-4 5/8"	8'-6 7/8"	13'-10 3/8"	13'-10 3/8"	8'-6 7/8"	HS 24.4
W33x141	35'-0"	34'-10"	11'-4 5/8"	8'-6 7/8"	13'-10 3/8"	13'-10 3/8"	8'-6 7/8"	HS 27.4
W36x135	35'-0"	34'-10"	11'-4 5/8"	8'-6 7/8"	13'-10 3/8"	13'-10 3/8"	8'-6 7/8"	HS 26.6
W36x150	40'-0"	39'-10"	13'-5/8"	10'-2 7/8"	15'-6 3/8"	15'-6 3/8"	10'-2 7/8"	HS 23.8

COMPOSITE DEFLECTION SCHEDULE							
DUE TO SIP FORMS, DECK SLAB, HAUNCH, AND TR3 RAIL DEFLECTION							
BEAM	MAX. SPAN	CL BRG.	0.1 & 0.9	0.2 & 0.8	0.3 & 0.7	0.4 & 0.6	0.5
W33x130	50'-0"	0.00"	0.21"	0.39"	0.54"	0.63"	.66"
W33x141	55'-0"	0.00"	0.28"	0.52"	0.71"	0.84"	0.88"
W36x135	55'-0"	0.00"	0.26"	0.50"	0.68"	0.80"	0.84"
W36x150	60'-0"	0.00"	0.33"	0.62"	0.84"	0.99"	1.04"

NON-COMPOSITE DEFLECTION SCHEDULE							
DUE TO SIP FORMS, DECK SLAB, HAUNCH, AND TR3 RAIL DEFLECTION							
BEAM	MAX. SPAN	CL BRG.	0.1 & 0.9	0.2 & 0.8	0.3 & 0.7	0.4 & 0.6	0.5
W33x130	35'-0"	0.00"	0.05"	0.10"	0.13"	0.15"	0.16"
W33x141	35'-0"	0.00"	0.05"	0.09"	0.12"	0.14"	0.15"
W36x135	35'-0"	0.00"	0.04"	0.08"	0.11"	0.13"	0.14"
W36x150	40'-0"	0.00"	0.07"	0.12"	0.17"	0.20"	0.21"

APPROVED BY BRIDGE ENGINEER *Robert M. Smith* DATE 4-27-2012

OKLAHOMA DEPARTMENT OF TRANSPORTATION
COUNTY BRIDGE STANDARDS (ENGLISH)

ROLLED BEAM DETAILS
32' CLEAR ROADWAY
30° SKEW