

**EXCAVATION PLAN**  
LEFT FORWARD SKEW SHOWN, RIGHT FORWARD SKEW OPPOSITE HAND

**PIPE UNDERDRAIN PLAN**  
LEFT FORWARD SKEW SHOWN, RIGHT FORWARD SKEW OPPOSITE HAND

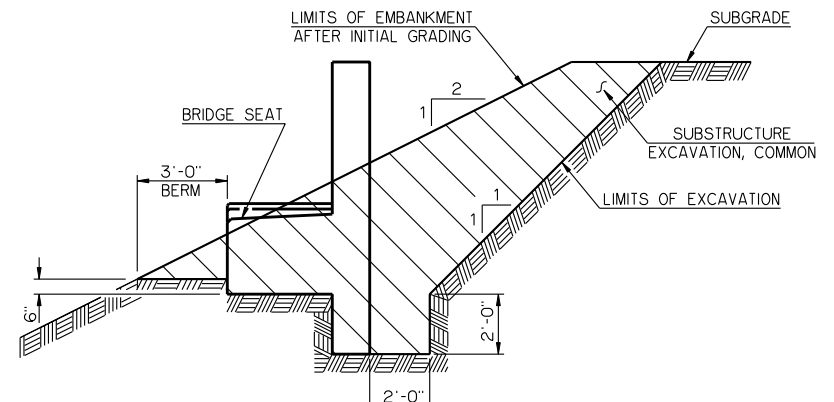

**SECTION A-A**

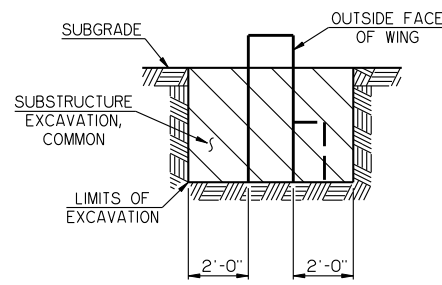

**SECTION C-C**

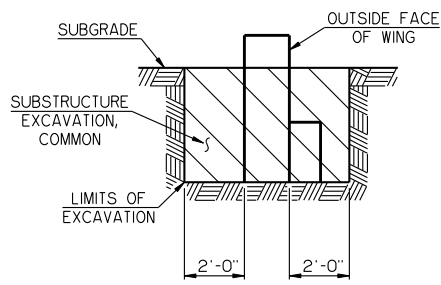

**SECTION D-D**

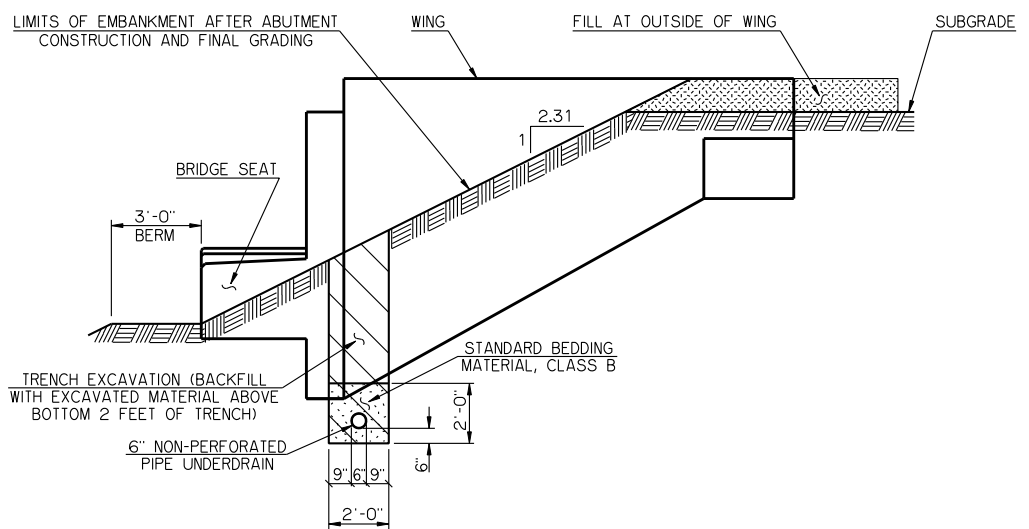

**SECTION F-F**

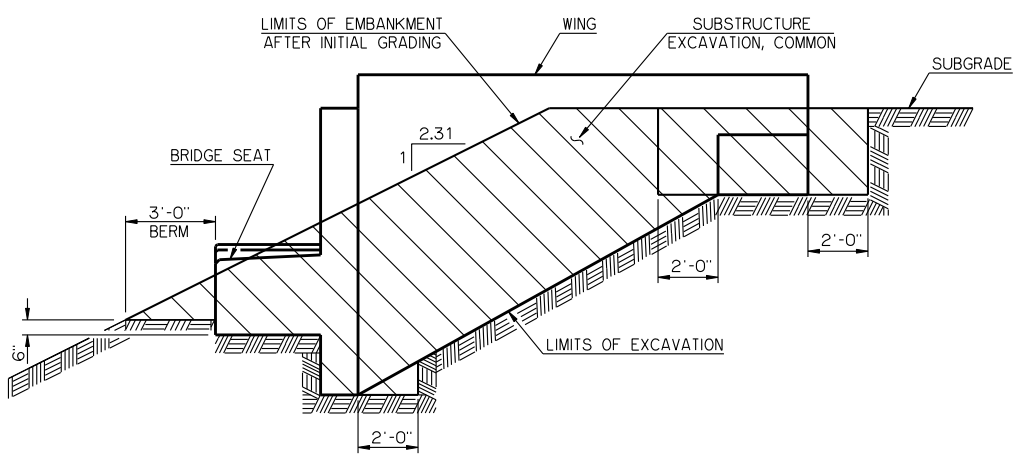

**SECTION B-B**

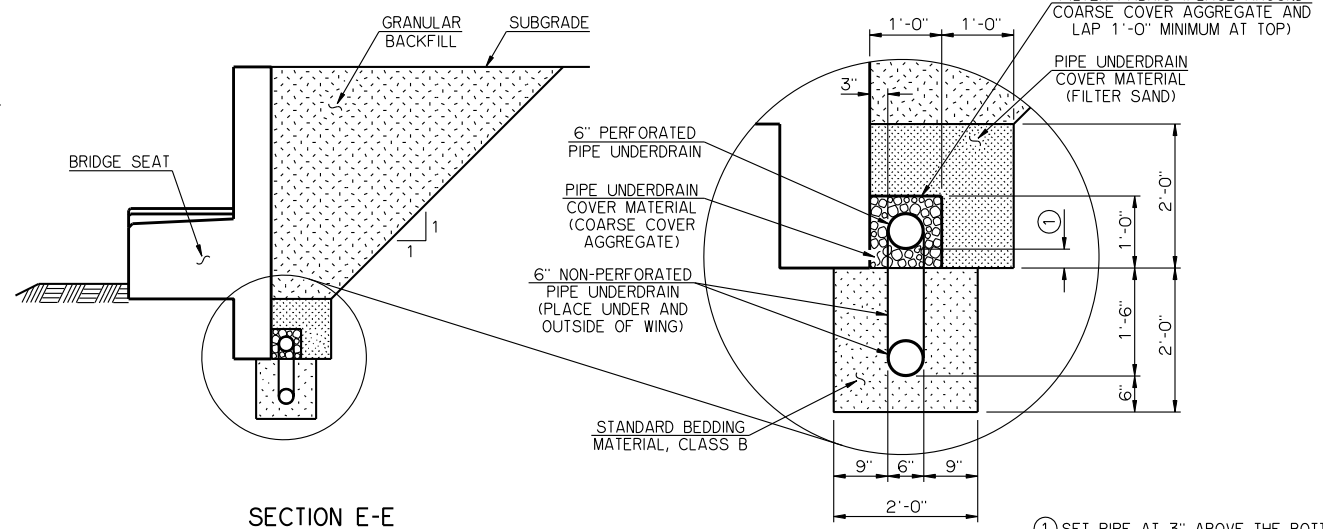

**SECTION E-E**

**NOTES**

CONCRETE MAY BE PLACED AGAINST THE LIMITS OF EXCAVATION IF THE MATERIAL IS EXCAVATED TO THE NEAT LINES OF THE ABUTMENT AND APPROVED BY THE ENGINEER. IF NECESSARY, FORMS SHALL BE USED ON THE BACK VERTICAL FACE OF THE ABUTMENT AND REMOVED AFTER THE CONCRETE HAS SET. THE MEASUREMENT AND PAYMENT FOR "SUBSTRUCTURE EXCAVATION COMMON" AT THE ABUTMENTS SHALL BE IN ACCORDANCE WITH THE DETAILS SHOWN IN THE PLANS.

GRANULAR BACKFILL SHALL NOT BE PLACED UNTIL THE CONCRETE IN THE ABUTMENT WINGS HAS ATTAINED A STRENGTH OF 3,000 PSI.

INSTALLATION OF THE PIPE UNDERDRAIN SHALL BE AS SHOWN IN THE PLANS AND ON ROADWAY STANDARD DRAWING PUD-3. THE EXTENT, LOCATION AND DEPTH OF THE 6" NON-PERFORATED PIPE UNDERDRAIN MAY BE ADJUSTED BY THE ENGINEER DURING CONSTRUCTION. ALL COST OF THE PERFORATED AND NON-PERFORATED PIPE, PIPE UNDERDRAIN COVER MATERIAL, FILTER FABRIC, TRENCH EXCAVATION, STANDARD BEDDING MATERIAL, PIPE CAPS, RODENT SCREENS, BACKFILLING OF TRENCH EXCAVATION, MATERIAL, LABOR, EQUIPMENT AND INCIDENTALS SHALL BE INCLUDED IN THE UNIT PRICE BID PER LINEAR FOOT OF "6" PERFORATED PIPE UNDERDRAIN" AND "6" NON-PERFORATED PIPE UNDERDRAIN."

APPROVED BY BRIDGE ENGINEER *Robert J. Duch* DATE 9-9-2011  
 OKLAHOMA DEPARTMENT OF TRANSPORTATION  
 COUNTY BRIDGE STANDARD (ENGLISH)  
**SUBSTRUCTURE EXCAVATION AND PIPE UNDERDRAIN ASSEMBLY DETAILS**  
 26' AND 32' CLEAR ROADWAY - CONVENTIONAL - SKEWED 30°  
 2009 SPECIFICATIONS CB26.32-C-SK30-ABUT-MISC 01E  
 CB-938E

① SET PIPE AT 3" ABOVE THE BOTTOM OF THE ABUTMENT AT THE LOW END.