

HALF ELEVATION AT ABUTMENT

HALF ELEVATION AT PIER

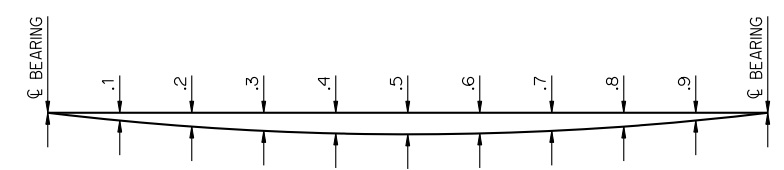

DEAD LOAD DEFLECTION DIAGRAM

BEAM SCHEDULE																				
SPAN	BEAM	BEAM LENGTH	A	B	N1	S1	L1	S2	N3	S3	L3	S4	N5	S5	L5	L6	BEARING STIFFENER	ELASTOMERIC PAD	LFD OPERATING RATING (2)	MAXIMUM (ADTT) _{sk} ALLOWABLE (3)
55'	W30 X 116	54'-8"	17'-10"	8'-11"	33	6"	16'-6"	7"	14	8"	9'-4"	4"	23	6"	11'-6"	5'-7"	1/2" X 4 1/2"	3/4" X 10 1/2" X 5'-3 1/2"	HS 31.6	539
60'	W33 X 130	59'-8"	19'-6"	9'-9"	36	6"	18'-0"	7"	16	8"	10'-8"	0"	26	6"	13'-0"	5'-7"	1/2" X 5"	3/4" X 11 1/2" X 5'-3"	HS 34.0	579
65'	W36 X 135	64'-8"	21'-2"	10'-7"	25	6"	12'-6"	7"	28	8"	18'-8"	0"	15	6"	7'-6"	5'-7"	3/4" X 5"	3/4" X 1'-0" X 5'-4 1/2"	HS 31.0	476
70'	W36 X 150	69'-8"	22'-10"	11'-5"	28	6"	14'-0"	7"	29	8"	19'-4"	4"	28	6"	14'-0"	6'-1"	1/2" X 5"	3/4" X 1'-0" X 5'-6"	HS 30.8	460
75'	W40 X 167	74'-8"	24'-6"	12'-3"	39	7"	22'-9"	6"	18	9"	13'-6"	0"	30	7"	17'-6"	5'-10"	1/2" X 5"	3/4" X 11 3/4" X 5'-5 1/2"	HS 33.6	527

DEFLECTION SCHEDULE						
SPAN	BEAM AND DIAPHRAGM DEFLECTION					
	CL BEARING	.1 AND .9	.2 AND .8	.3 AND .7	.4 AND .6	.5
55'	0.00"	0.05"	0.10"	0.14"	0.16"	0.17"
60'	0.00"	0.06"	0.12"	0.16"	0.19"	0.20"
65'	0.00"	0.08"	0.14"	0.20"	0.23"	0.24"
70'	0.00"	0.10"	0.18"	0.25"	0.29"	0.31"
75'	0.00"	0.11"	0.21"	0.28"	0.33"	0.35"

SPAN	STEEL SIP FORMS, DECK SLAB, HAUNCH, AND CONCRETE TRAFFIC RAIL (TR3) DEFLECTION (4)					
	CL BEARING	.1 AND .9	.2 AND .8	.3 AND .7	.4 AND .6	.5
55'	0.00"	0.39"	0.74"	1.01"	1.18"	1.24"
60'	0.00"	0.41"	0.78"	1.07"	1.25"	1.31"
65'	0.00"	0.49"	0.93"	1.27"	1.49"	1.57"
70'	0.00"	0.58"	1.09"	1.50"	1.75"	1.84"
75'	0.00"	0.60"	1.13"	1.55"	1.82"	1.91"

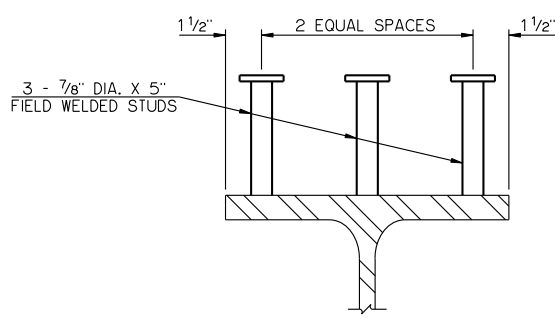
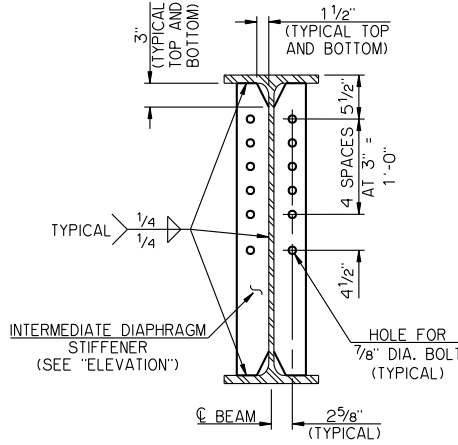
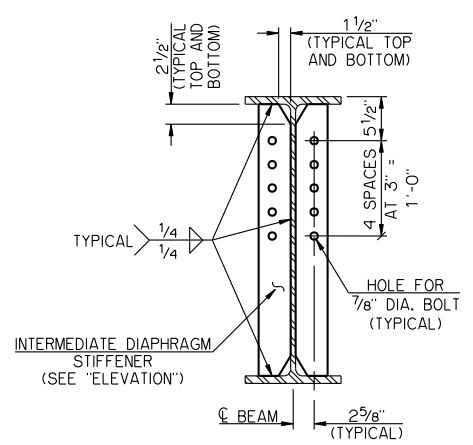

SHEAR CONNECTOR DETAIL

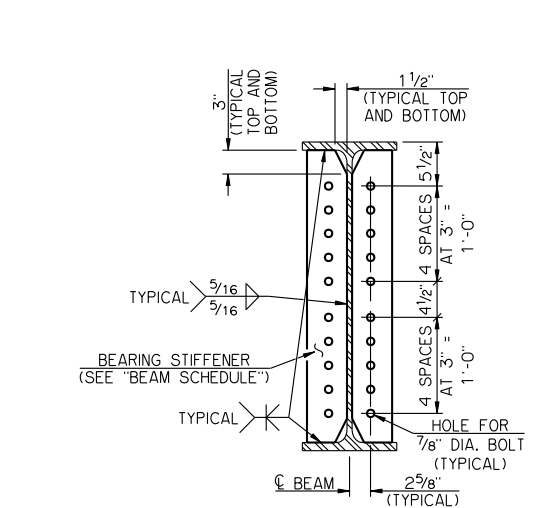
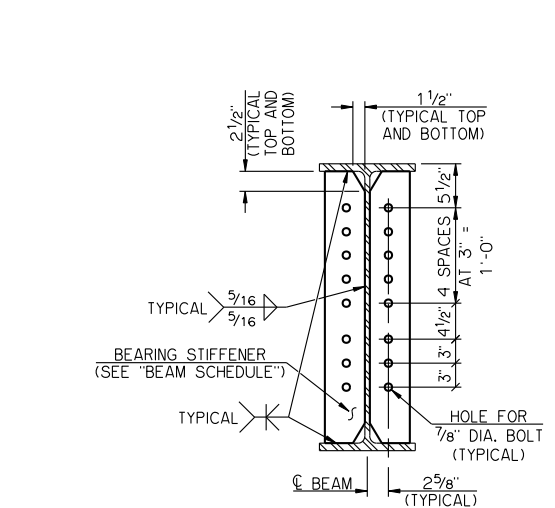
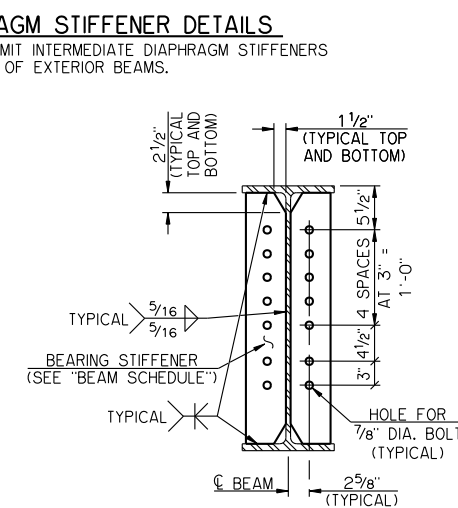
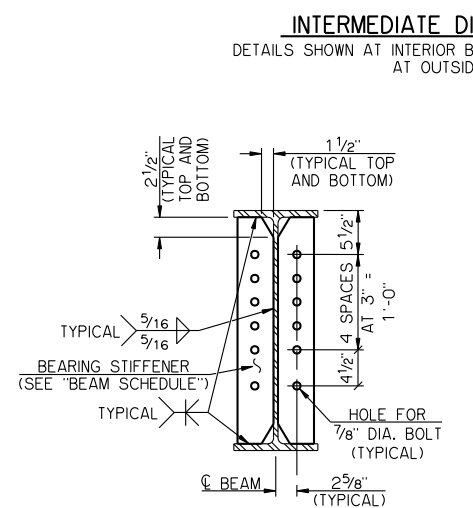

BEARING STIFFENER DETAILS

DETAILS SHOWN AT PIER END OF INTERIOR BEAM. OMIT BOLT HOLES ONLY IN BEARING STIFFENERS AT OUTSIDE FACE OF EXTERIOR BEAMS AND AT ABUTMENT END OF ALL BEAMS.

NOTES
 STRUCTURAL STEEL FOR ROLLED BEAMS AND ALL STIFFENER PLATES SHALL CONFORM TO AASHTO M 270 (ASTM A 709), GRADE 50W, WEATHERING STEEL. ADDITIONALLY, THE STRUCTURAL STEEL SHALL SATISFY THE CHARPY V-NOTCH IMPACT TEST REQUIREMENTS OF AASHTO M 270 FOR ZONE 2 (NON-FRACTURE CRITICAL). SHEAR CONNECTORS SHALL CONFORM TO AASHTO M 169 (ASTM A 108), COLD DRAWN BARS, GRADES 1015, 1018 OR 1020, SEMI-KILLED OR FULLY KILLED DEOXIDATION

BEAMS SHALL BE CAMBERED TO ACCOUNT FOR VERTICAL CURVE, IF NECESSARY. IF CAMBERING IS NOT REQUIRED, PLACE NATURAL CAMBER UP.

CONTRACTOR MAY ELECT TO FABRICATE PLATE GIRDERS USING EQUIVALENT PLATE SIZES IN LIEU OF ROLLED BEAM SHAPE SHOWN. WEB TO FLANGE WELDS SHALL BE MINIMUM 5/16" FILLET WELDS. NON-DESTRUCTIVE TESTING WILL BE REQUIRED AS APPROPRIATE. COSTS TO CONSTRUCT PLATE GIRDERS SHALL BE AT THE CONTRACTOR'S EXPENSE.

TERMINATE FILLET WELDS 3/8" FROM THE EDGES OF CLIPPED CORNERS AND NON-CLIPPED CORNERS OF STIFFENER PLATES.

FOR ADDITIONAL DETAILS, SEE "DIAPHRAGM DETAILS."

- ELASTOMERIC PAD SHALL HAVE A 50 DUROMETER HARDNESS AND CONSIST OF A SINGLE LAYER. THE PAD SHALL EXTEND 1/2" BEYOND THE END OF THE BEAM AS SHOWN.
- THE LFD OPERATING RATING SHOWN IN THE TABLE IS FOR THE ROLLED BEAMS ONLY AND APPLIES ONLY TO THE ROLLED BEAMS OF A BRIDGE CONSTRUCTED IN STRICT CONFORMANCE TO ALL RELEVANT DETAILS CONTAINED IN THE COMPLETE SET OF COUNTY BRIDGE STANDARDS AND TO THE ODOT STANDARD SPECIFICATIONS.
- THIS STANDARD SHALL NOT BE USED IF THE (ADTT)_{sk} EXCEEDS THE VALUE SHOWN IN THE TABLE. THE (ADTT)_{sk} IS THE NUMBER OF TRUCKS PER DAY TRAVELING THE BRIDGE IN ONE DIRECTION AVERAGED OVER A 75-YEAR DESIGN LIFE. A TRUCK IS DEFINED AS ANY VEHICLE HAVING MORE THAN EITHER TWO AXLES OR FOUR WHEELS.
- THE DEAD LOAD DEFLECTIONS SHOWN AT THE TENTH POINTS ARE THE THEORETICAL BEAM DEFLECTIONS DUE TO A 5 PSF STEEL SIP FORMS ALLOWANCE, DECK SLAB, HAUNCH AND CONCRETE TRAFFIC RAIL (TR3). THE DEAD LOAD DEFLECTIONS SHALL BE ACCOUNTED FOR IN THE HAUNCH DEPTH CALCULATIONS.

APPROVED BY BRIDGE ENGINEER *Robert J. Dusch* DATE 9-9-2011
 OKLAHOMA DEPARTMENT OF TRANSPORTATION
 COUNTY BRIDGE STANDARD (ENGLISH)
ROLLED BEAM DETAILS
55' THRU 75' SPANS
 32' CLEAR ROADWAY - INTEGRAL - SKEWED 0°
 2009 SPECIFICATIONS CB32-I-SKO-RB-5575 01E
 CB-845E