

FIXED BEARING PLAN
ANCHOR BOLT ASSEMBLIES NOT SHOWN

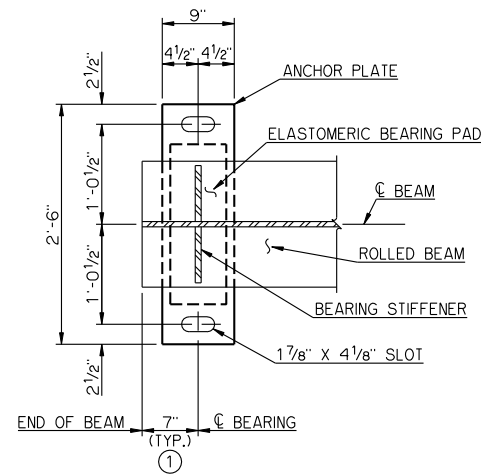

EXPANSION BEARING PLAN
ANCHOR BOLT ASSEMBLIES NOT SHOWN

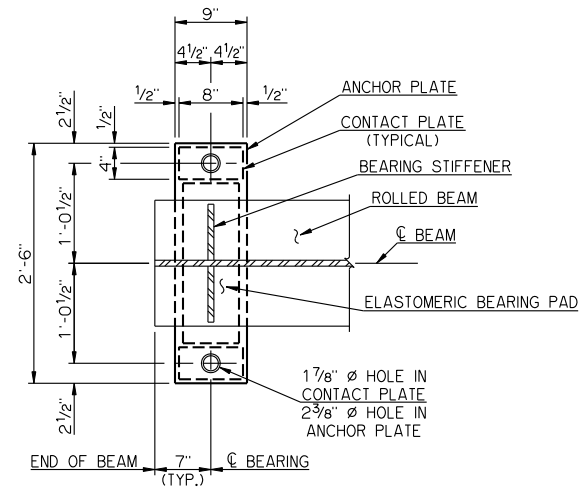

FIXED BEARING PLAN
ANCHOR BOLT ASSEMBLIES NOT SHOWN

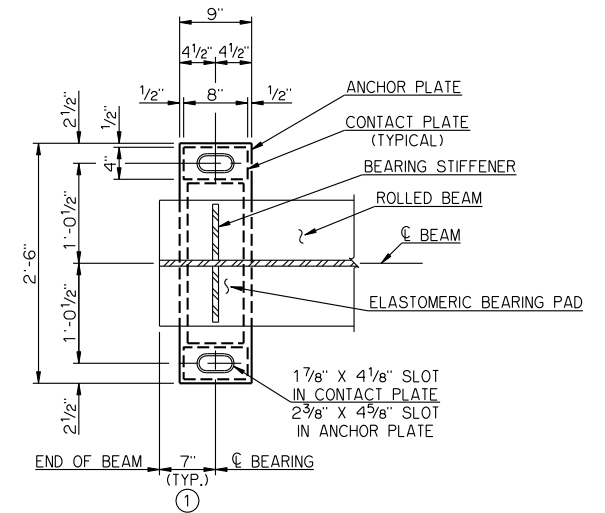

EXPANSION BEARING PLAN
ANCHOR BOLT ASSEMBLIES NOT SHOWN

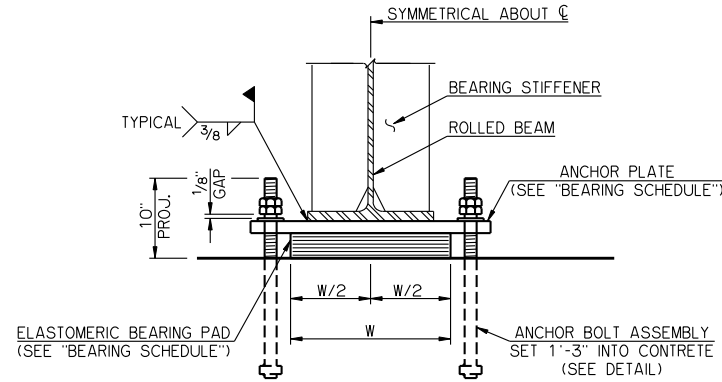

END VIEW

BEARING DETAILS
30' THRU 90' SPANS

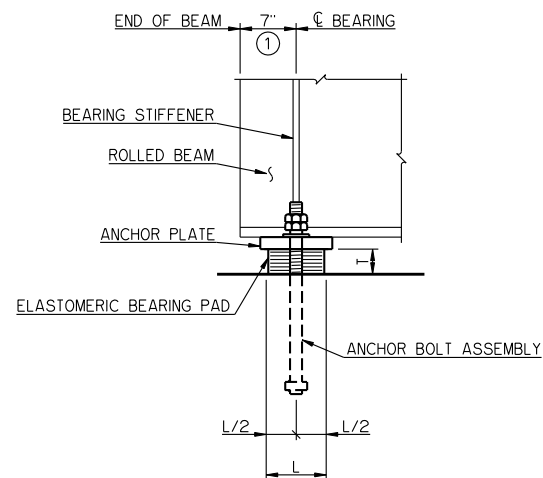

SIDE VIEW

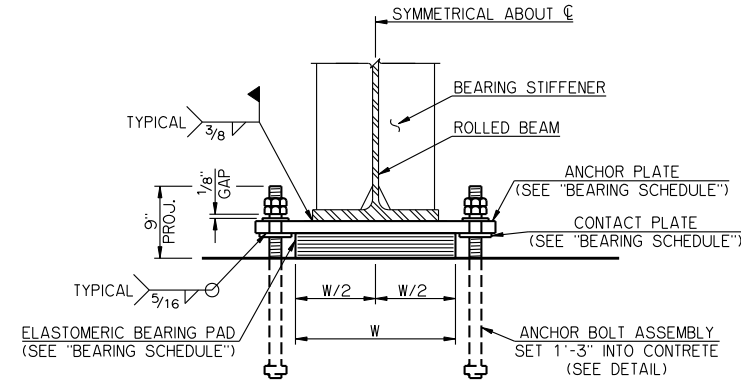

END VIEW

BEARING DETAILS
95' AND 100' SPANS

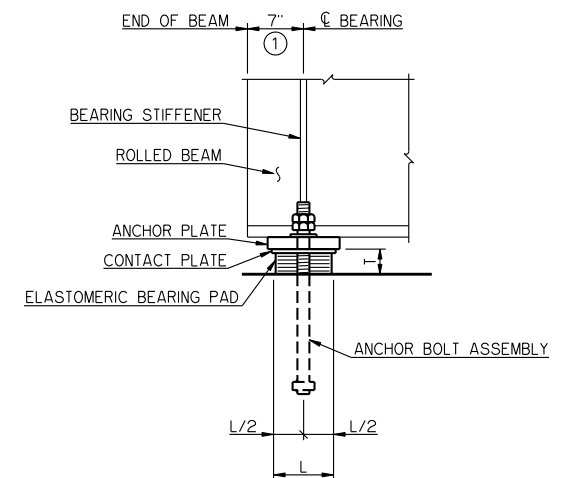

SIDE VIEW

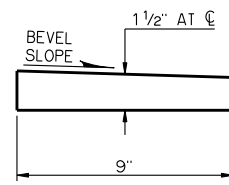

BEVELED ANCHOR PLATE DETAIL

BEVELED ANCHOR PLATE IS REQUIRED WHEN ANGLE BETWEEN UNDERSIDE OF BEAM AND HORIZONTAL EXCEEDS 1.0%. BEVEL SLOPE TO MATCH ANGLE BETWEEN BEAM AND HORIZONTAL. PAINT THICKER EDGE RED.

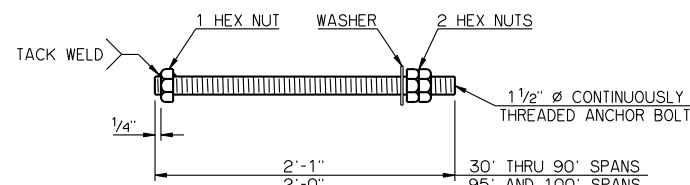

ANCHOR BOLT ASSEMBLY DETAIL

BEARING SCHEDULE

SPAN	ANCHOR PLATE	CONTACT PLATE	60 DUROMETER ELASTOMERIC BEARING PAD				MAXIMUM EXPANSION LENGTH WITHOUT BONDING
			SIZE (T X L X W)	COVER LAYER	INNER LAYER	LAMINATE PLATE	
30'	1 1/2" X 9" X 2'-6"	---	4 1/8" X 6 1/2" X 1'-4"	2-1/4"	7-3/8"	8-1/8"	65'
35'	1 1/2" X 9" X 2'-6"	---	4 1/8" X 6 1/2" X 1'-4"	2-1/4"	7-3/8"	8-1/8"	75'
40'	1 1/2" X 9" X 2'-6"	---	4 1/8" X 6 3/4" X 1'-4"	2-1/4"	7-3/8"	8-1/8"	80'
45'	1 1/2" X 9" X 2'-6"	---	4 1/8" X 7" X 1'-4"	2-1/4"	7-3/8"	8-1/8"	90'
50'	1 1/2" X 9" X 2'-6"	---	3 5/8" X 7" X 1'-4"	2-1/4"	6-3/8"	7-1/8"	90'
55'	1 1/2" X 9" X 2'-6"	---	3 5/8" X 7" X 1'-4"	2-1/4"	6-3/8"	7-1/8"	90'
60'	1 1/2" X 9" X 2'-6"	---	3 5/8" X 7" X 1'-4"	2-1/4"	6-3/8"	7-1/8"	115'
65'	1 1/2" X 9" X 2'-6"	---	3 5/8" X 7" X 1'-4"	2-1/4"	6-3/8"	7-1/8"	125'
70'	1 1/2" X 9" X 2'-6"	---	3 5/8" X 7" X 1'-6"	2-1/4"	6-3/8"	7-1/8"	120'
75'	1 1/2" X 9" X 2'-6"	---	3 5/8" X 7" X 1'-6"	2-1/4"	6-3/8"	7-1/8"	130'
80'	1 1/2" X 9" X 2'-6"	---	3 5/8" X 7" X 1'-6"	2-1/4"	6-3/8"	7-1/8"	140'
85'	1 1/2" X 9" X 2'-6"	---	3 1/8" X 7" X 1'-8"	2-1/4"	5-3/8"	6-1/8"	120'
90'	1 1/2" X 9" X 2'-6"	---	3 1/8" X 7" X 1'-8"	2-1/4"	5-3/8"	6-1/8"	130'
95'	1 1/2" X 9" X 2'-6"	1/2" X 4" X 8"	3 1/8" X 7" X 1'-8"	2-1/4"	5-3/8"	6-1/8"	130'
100'	1 1/2" X 9" X 2'-6"	1/2" X 4" X 8"	3 1/8" X 7" X 1'-8"	2-1/4"	5-3/8"	6-1/8"	130'

NOTES

STRUCTURAL STEEL FOR ANCHOR PLATES, CONTACT PLATES AND CONTINUOUSLY THREADED ANCHOR BOLTS SHALL CONFORM TO AASHTO M 270 (ASTM A 709), GRADE 50W, WEATHERING STEEL (CHARPY V-NOTCH TESTING NOT REQUIRED). HEX NUTS SHALL CONFORM TO AASHTO M 291 (ASTM A 563). WASHERS SHALL CONFORM TO AASHTO M 293 (ASTM F 436), TYPE 3. ANCHOR BOLT ASSEMBLIES SHALL BE GALVANIZED, AND ALL OTHER STEEL PARTS COMPRISING THE BEARING ASSEMBLIES SHALL BE PAINTED WITH THE IZ-E-U PAINT SYSTEM.

ANCHOR BOLTS SHALL BE CENTERED IN SLOTS DURING SETTING OF BEAMS. DIMENSION MAY VARY AT EXPANSION BEARING DEPENDING ON TEMPERATURE AT THE TIME OF BEAM SETTING.

APPROVED BY BRIDGE ENGINEER *Robert J. Duch* DATE 9-9-2011

OKLAHOMA DEPARTMENT OF TRANSPORTATION
COUNTY BRIDGE STANDARD (ENGLISH)

BEARING DETAILS
ROLLED BEAMS

32' CLEAR ROADWAY - CONVENTIONAL - SKEWED 0° AND 30°

2009 SPECIFICATIONS CB32-C-SKO.30-BRG-RB 01E CB-743E