

TYPICAL SECTION THRU ABUTMENT

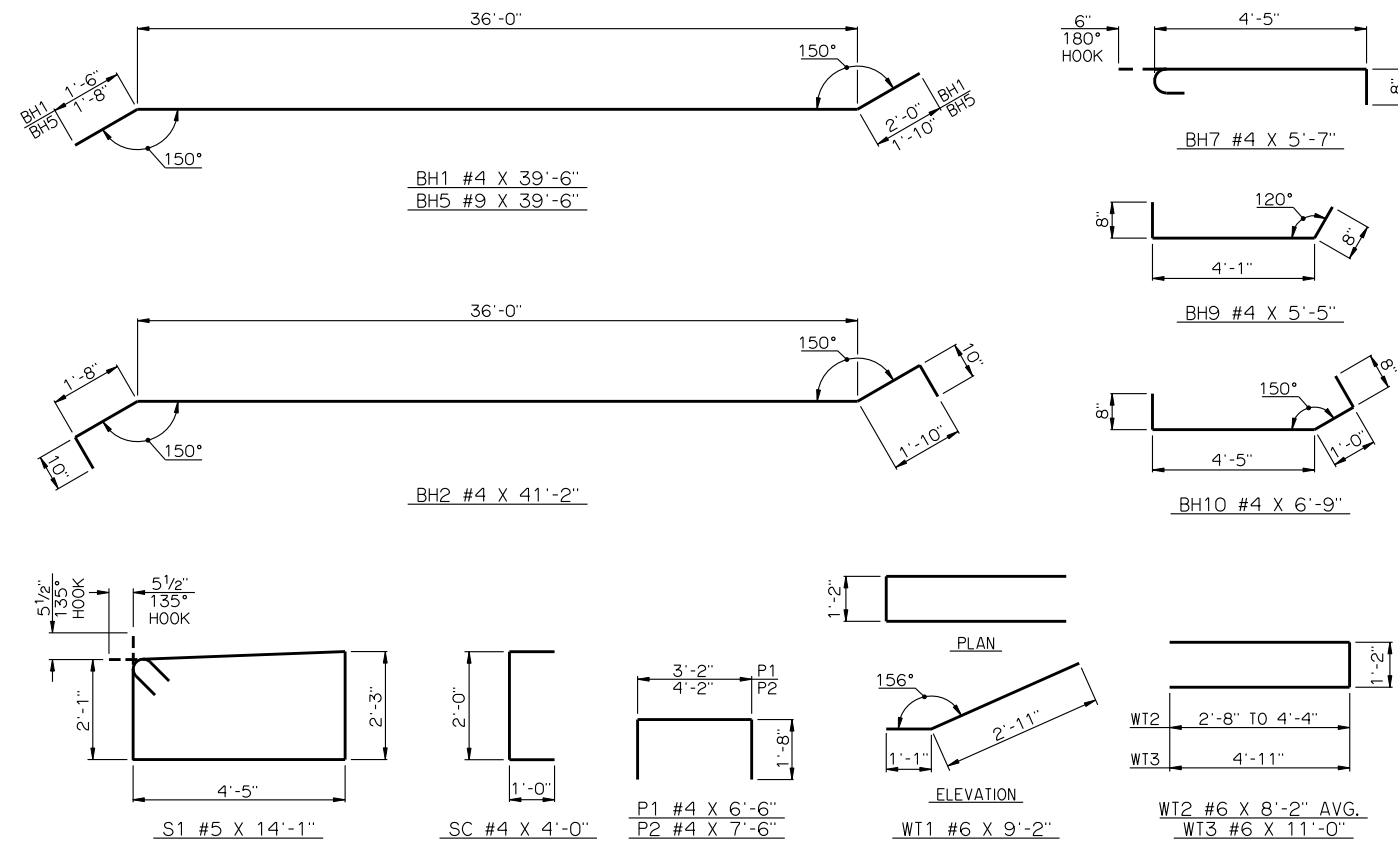

DETAILS OF BENT REINFORCING STEEL

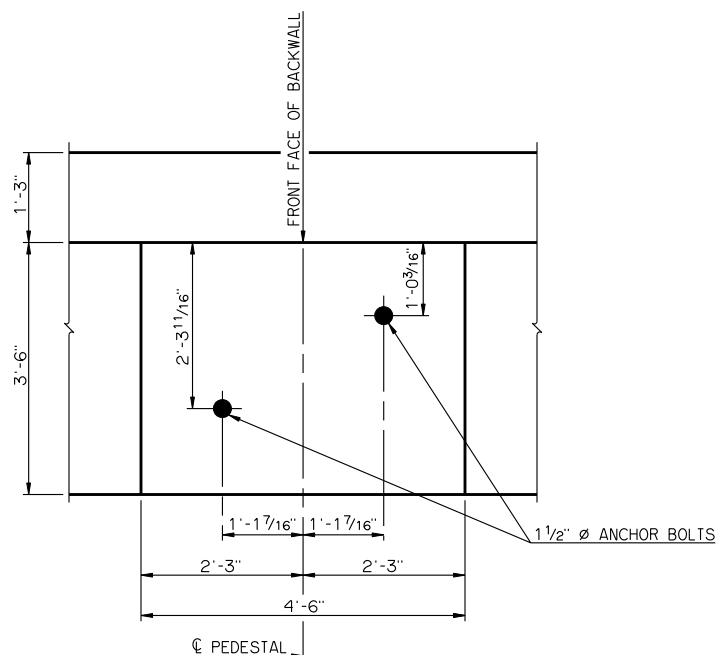

DETAIL OF PEDESTAL WITH LAYOUT OF ANCHOR BOLTS

BAR LIST - ONE ABUTMENT					
MARK	NO.	SIZE	FORM	LENGTH	LENGTH VARIATION
	BH1	8 #4	BNT.	39'-6"	-
	BH2	9 #4	BNT.	41'-2"	-
	BH3	6 #9	STR.	38'-5" AVG.	37'-6" TO 39'-4"
	BH4	4 #9	STR.	38'-5" AVG.	37'-6" TO 39'-4"
	BH5	2 #9	BNT.	39'-6"	-
	BH6	1 #4	STR.	37'-6"	-
	BH7	21 #4	BNT.	5'-7"	-
	BH8	2 #9	STR.	12'-9"	-
	BH9	3 #4	BNT.	5'-5"	-
	BH10	3 #4	BNT.	6'-9"	-
①	BV1	38 #4	STR.	9'-3" AVG.	9'-1" TO 9'-5"
①	BV2	38 #5	STR.	9'-3" AVG.	9'-1" TO 9'-5"
	BV3	8 #6	STR.	9'-1"	-
	P1	24 #4	BNT.	6'-6"	-
	P2	16 #4	BNT.	7'-6"	-
	S1	42 #5	BNT.	14'-1"	-
	SC	6 #4	BNT.	4'-0"	-
	WT1	2 #6	BNT.	9'-2"	-
②	WT2	4 #6	BNT.	8'-2" AVG.	6'-6" TO 9'-10"
	WT3	22 #6	BNT.	11'-0"	-

- ① NO. INCLUDES TWO SETS OF 19 BARS
- ② NO. INCLUDES TWO SETS OF 2 BARS

APPROVED BY BRIDGE ENGINEER *Robert J. Hush* DATE 10-31-2011

OKLAHOMA DEPARTMENT OF TRANSPORTATION
 COUNTY BRIDGE STANDARD (ENGLISH)

ABUTMENT DETAILS
 TYPE IV P.C. BEAMS
 (SHEET NO. 2 OF 2)

32' CLEAR ROADWAY - CONVENTIONAL - SKEWED 30°

2009 SPECIFICATIONS CB32-C-SK30-ABUT-PC4-2 02E CB-575E