

FIXED BEARING PLAN
ANCHOR BOLT ASSEMBLIES NOT SHOWN

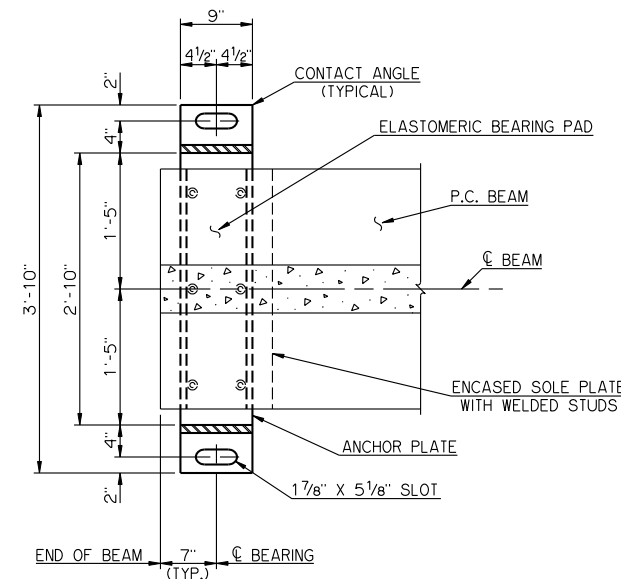

EXPANSION BEARING PLAN
ANCHOR BOLT ASSEMBLIES NOT SHOWN

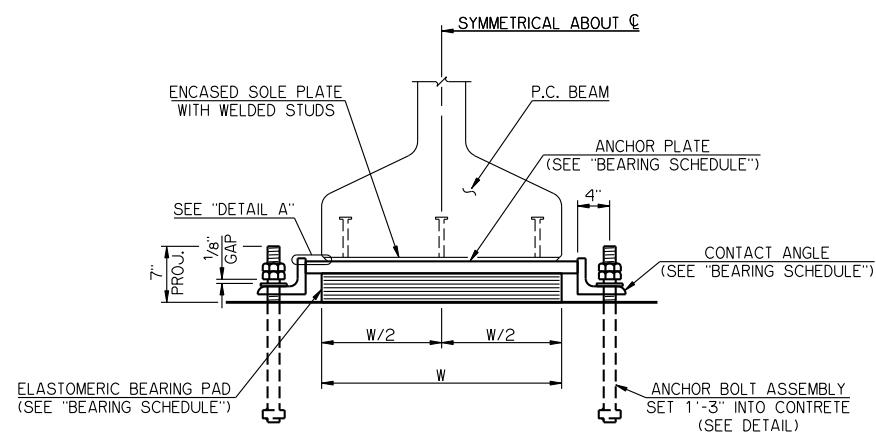

END VIEW

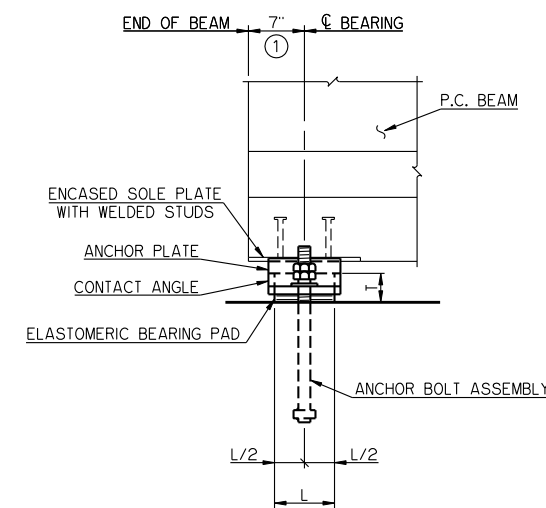

SIDE VIEW

BEARING DETAILS

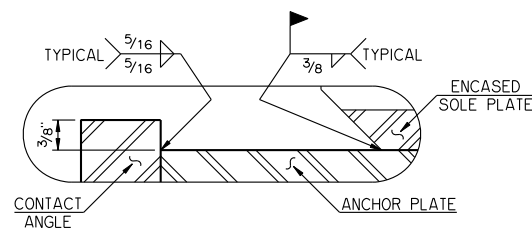

DETAIL A

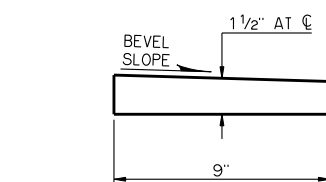

BEVELED ANCHOR PLATE DETAIL

BEVELED ANCHOR PLATE IS REQUIRED WHEN ANGLE BETWEEN UNDERSIDE OF BEAM AND HORIZONTAL EXCEEDS 1.0%. BEVEL SLOPE TO MATCH ANGLE BETWEEN BEAM AND HORIZONTAL. PAINT THICKER EDGE RED.

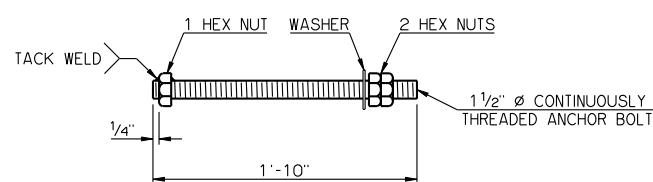

ANCHOR BOLT ASSEMBLY DETAIL

SPAN	ANCHOR PLATE	CONTACT ANGLE ②	60 DUROMETER ELASTOMERIC BEARING PAD			MAXIMUM EXPANSION LENGTH WITHOUT BONDING	
			SIZE (T X L X W)	COVER LAYER	INNER LAYER		
110'	1 1/2" X 9" X 2'-10"	6 X 4 1/2 X 1 X 9"	3 9/8" X 7 1/4" X 2'-6"	2-1/4"	6-3/8"	7-1/8"	305'
115'	1 1/2" X 9" X 2'-10"	6 X 4 1/2 X 1 X 9"	3 9/8" X 7 1/4" X 2'-6"	2-1/4"	6-3/8"	7-1/8"	305'
120'	1 1/2" X 9" X 2'-10"	6 X 4 1/2 X 1 X 9"	3 9/8" X 7 1/4" X 2'-6"	2-1/4"	6-3/8"	7-1/8"	305'
125'	1 1/2" X 9" X 2'-10"	6 X 4 1/2 X 1 X 9"	3 9/8" X 7 1/2" X 2'-6"	2-1/4"	6-3/8"	7-1/8"	305'
130'	1 1/2" X 9" X 2'-10"	6 X 4 1/2 X 1 X 9"	3 9/8" X 7 1/2" X 2'-6"	2-1/4"	6-3/8"	7-1/8"	305'
135'	1 1/2" X 9" X 2'-10"	6 X 4 1/2 X 1 X 9"	3 9/8" X 7 1/2" X 2'-6"	2-1/4"	6-3/8"	7-1/8"	305'

NOTES

STRUCTURAL STEEL FOR ANCHOR PLATES, CONTACT ANGLES AND CONTINUOUSLY THREADED ANCHOR BOLTS SHALL CONFORM TO AASHTO M 270 (ASTM A 709), GRADE 50W, WEATHERING STEEL (CHARPY V-NOTCH TESTING NOT REQUIRED). HEX NUTS SHALL CONFORM TO AASHTO M 291 (ASTM A 563). WASHERS SHALL CONFORM TO AASHTO M 293 (ASTM F 436), TYPE 3. ANCHOR BOLT ASSEMBLIES SHALL BE GALVANIZED, AND ALL OTHER STEEL PARTS COMPRISING THE BEARING ASSEMBLIES SHALL BE PAINTED WITH THE IZ-E-U PAINT SYSTEM.

- ① ANCHOR BOLTS SHALL BE CENTERED IN SLOTS DURING SETTING OF BEAMS. DIMENSION MAY VARY AT EXPANSION BEARING DEPENDING ON TEMPERATURE AT THE TIME OF BEAM SETTING.
- ② FABRICATE L 6 X 4 1/2 X 1 BY CUTTING 1/2" FROM VERTICAL LEG OF L 6 X 6 X 1.

APPROVED BY BRIDGE ENGINEER *Robert Dush* DATE **9-9-2011**

OKLAHOMA DEPARTMENT OF TRANSPORTATION
COUNTY BRIDGE STANDARD (ENGLISH)

BEARING DETAILS
TYPE J P.C. BEAMS

26' CLEAR ROADWAY - CONVENTIONAL - SKEWED 0° AND 30°

2009 SPECIFICATIONS CB26-C-SKO..30-BRG-PC5 01E CB-362E