

**ELEVATION OF INTERMEDIATE DIAPHRAGM**  
TYPE II, B, III, C AND IV P.C. BEAMS

FOR SPANS OF 100' OR LESS IN LENGTH - INCLUDE ONE LINE OF INTERMEDIATE DIAPHRAGMS PER SPAN.  
FOR SPANS OVER 100' IN LENGTH - INCLUDE TWO LINES OF INTERMEDIATE DIAPHRAGMS PER SPAN.

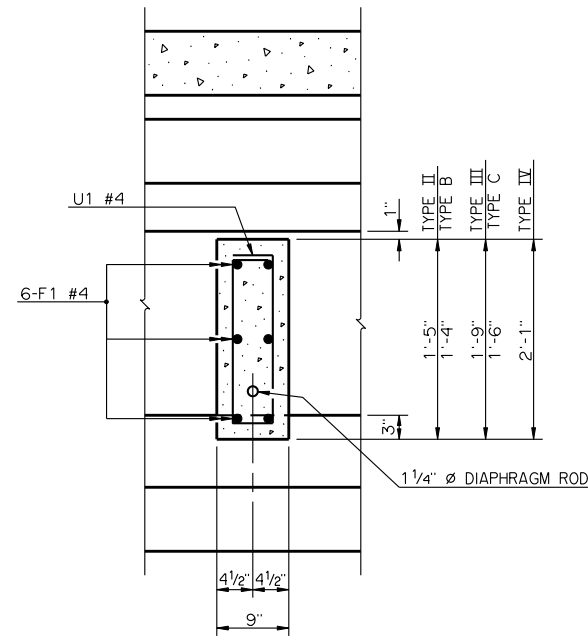

**SECTION A-A**

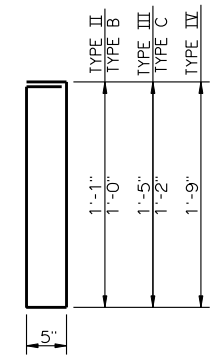

- U1 #4 X 3'-5" - TYPE II
- U1 #4 X 3'-3" - TYPE B
- U1 #4 X 4'-1" - TYPE III
- U1 #4 X 3'-7" - TYPE C
- U1 #4 X 4'-9" - TYPE IV

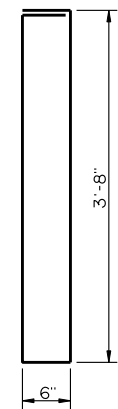

- U1 #4 X 8'-10" - TYPE BT-72 AND TYPE J

**DETAILS OF BENT REINFORCING STEEL**

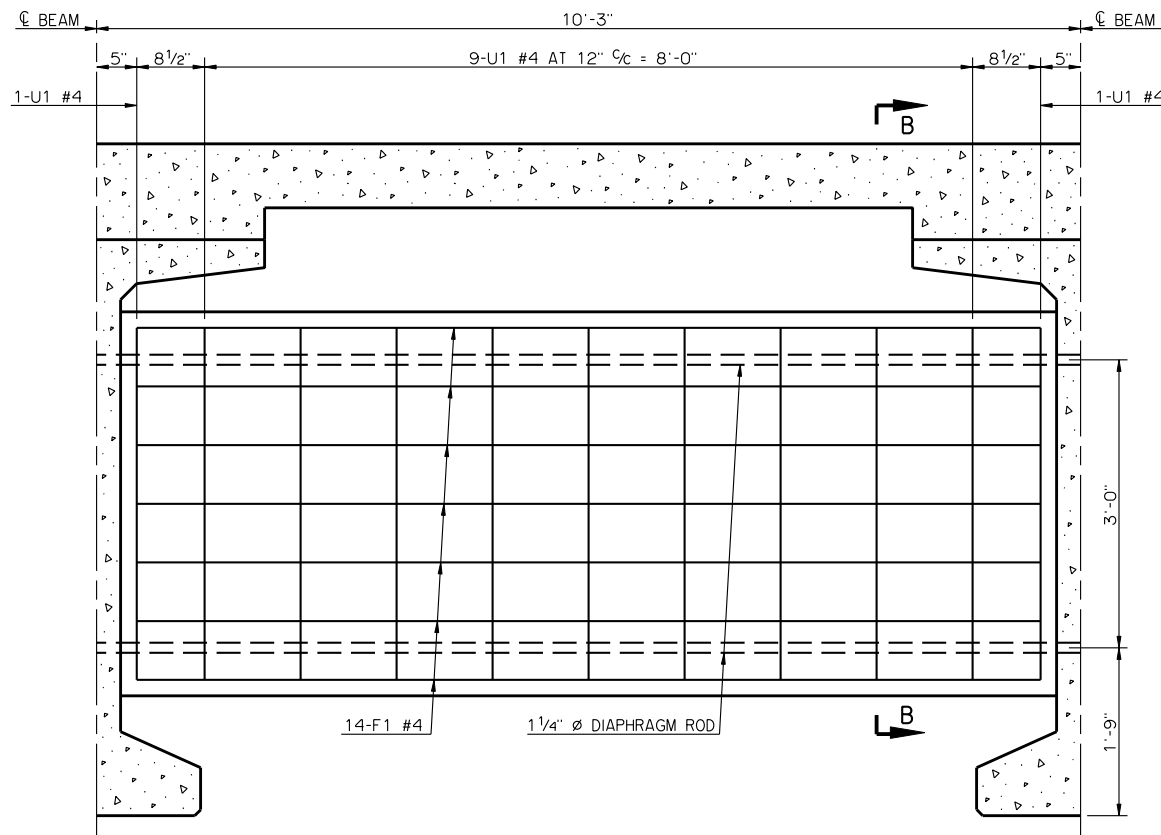

**ELEVATION OF INTERMEDIATE DIAPHRAGM**  
TYPE BT-72 AND TYPE J P.C. BEAMS

FOR ALL SPAN LENGTHS - INCLUDE TWO LINES OF INTERMEDIATE DIAPHRAGMS PER SPAN.

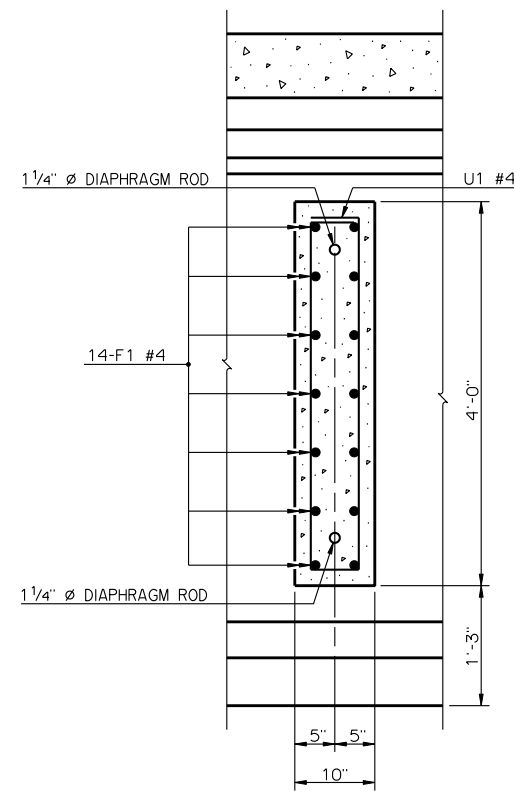

**SECTION B-B**

BAR LIST - ONE INTERMEDIATE DIAPHRAGM					
P.C. BEAM	MARK	NO.	SIZE	FORM	LENGTH
TYPE II	U1	10	#4	BNT.	3'-5"
	F1	6	#4	STR.	9'-5"
TYPE B	U1	10	#4	BNT.	3'-3"
	F1	6	#4	STR.	9'-4"
TYPE III	U1	10	#4	BNT.	4'-1"
	F1	6	#4	STR.	9'-4"
TYPE C	U1	10	#4	BNT.	3'-7"
	F1	6	#4	STR.	9'-4"
TYPE IV	U1	10	#4	BNT.	4'-9"
	F1	6	#4	STR.	9'-3"
TYPE BT-72	U1	11	#4	BNT.	8'-10"
	F1	14	#4	STR.	9'-5"
TYPE J	U1	11	#4	BNT.	8'-10"
	F1	14	#4	STR.	9'-5"

APPROVED BY BRIDGE ENGINEER *Robert D. Dush* DATE 9-9-2011

OKLAHOMA DEPARTMENT OF TRANSPORTATION  
COUNTY BRIDGE STANDARD (ENGLISH)

**INTERMEDIATE DIAPHRAGM DETAILS**  
P.C. BEAMS

26' CLEAR ROADWAY - CONVENTIONAL - SKEWED 0° AND 30°