

HALF SECTION AT END DIAPHRAGM

HALF SECTION AT INTERMEDIATE DIAPHRAGM

TYPICAL CROSS SECTION

NOTES

- ROTATE HOOKS ON AC BARS TO MAINTAIN MINIMUM CLEARANCE.
- DO NOT PLACE THE CONCRETE FOR THE DECK SLAB OR APPLY OTHER MASSIVE LOADS TO THE BEAMS, INTERMEDIATE DIAPHRAGMS OR END DIAPHRAGMS UNTIL THE CONCRETE IN THE INTERMEDIATE AND END DIAPHRAGMS HAS BEEN IN PLACE A MINIMUM OF 10 DAYS OR AT THE DISCRETION OF THE ENGINEER. THIS TIME MAY BE SHORTENED IF THE CONCRETE HAS ATTAINED 80% OF THE SPECIFIED COMPRESSIVE STRENGTH.
- STAY-IN-PLACE STEEL DECK FORMS MAY BE USED IF THE MINIMUM DECK SLAB THICKNESS OF 8" IS OBTAINED BY MEASURING FROM THE TOP OF THE DECK SLAB TO THE TOP PORTION OF THE STEEL CORRUGATION. NO ADDITIONAL CONCRETE WEIGHT OF THE DECK SLAB IS PERMITTED. ADDITIONAL STEEL WEIGHT OF THE DECK FORMS SHALL NOT EXCEED 5 PSF. STAY-IN-PLACE PRESTRESSED CONCRETE DECK FORMS MAY BE USED IF THE FOLLOWING CONDITIONS ARE MET:
 - 1) SHOP DRAWINGS AND STRUCTURAL CALCULATIONS FOR THE FORMS ARE SUBMITTED TO THE BRIDGE ENGINEER FOR APPROVAL.
 - 2) A NEW STRUCTURAL DESIGN, STRUCTURAL CALCULATIONS, AND A NEW REINFORCING SCHEDULE FOR THE DECK SLAB ARE SUBMITTED TO THE BRIDGE ENGINEER FOR APPROVAL.
 - 3) SHOP DRAWINGS, NEW DECK SLAB REINFORCING SCHEDULE AND STRUCTURAL DESIGNS AND CALCULATIONS SHALL BE PREPARED BY AND SEALED BY A PROFESSIONAL ENGINEER REGISTERED IN THE STATE OF OKLAHOMA.
- ALL COSTS ASSOCIATED WITH THE USE OF STAY-IN-PLACE FORMS, INCLUDING ALL PROFESSIONAL SERVICES, MATERIAL, LABOR, EQUIPMENT AND INCIDENTALS, SHALL BE AT THE CONTRACTOR'S EXPENSE. FOR ADDITIONAL INFORMATION CONCERNING THE USE OF STAY-IN-PLACE FORMS, SEE SECTION 502 OF THE STANDARD SPECIFICATIONS.

THE DECK SLAB SHALL BE POURED ONE SPAN AT A TIME. A SPAN ADJACENT TO A FIXED PIER SHALL NOT BE POURED UNTIL AT LEAST 48 HOURS AFTER THE POUR OF ANY ADJACENT SPAN HAS BEEN COMPLETED.

CONSTRUCTION JOINTS AT THE FIXED PIERS SHALL NOT BE KEYED. IN THE EVENT OF AN EMERGENCY, POURING OF THE DECK SLAB MAY BE HALTED WITH A CONSTRUCTION JOINT MADE PERPENDICULAR TO THE DIRECTION OF TRAFFIC AS DIRECTED BY THE ENGINEER. ALL LONGITUDINAL REINFORCING STEEL SHALL BE CONTINUOUS THROUGH ALL CONSTRUCTION JOINTS. NO HEAVY EQUIPMENT WILL BE PERMITTED ON THE FINISHED DECK SLAB WITHIN 5'-0" OF ANY CONSTRUCTION JOINT UNTIL THE DECK SLAB IS IN PLACE ON BOTH SIDES OF THE RESPECTIVE JOINT.

DO NOT SAW-CUT GROOVE THE DECK SLAB WITHIN 6" OF ANY CONSTRUCTION JOINT. FOR BAR LIST AND DETAILS OF BENT REINFORCING STEEL, SEE DECK SLAB BAR LIST.

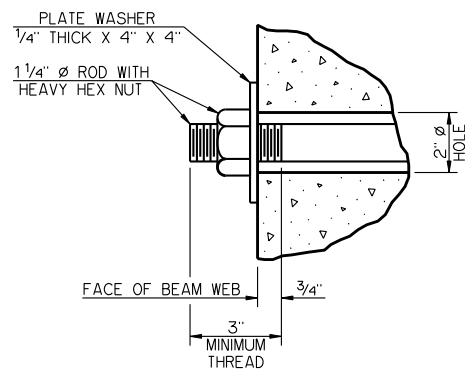

DETAIL "A"

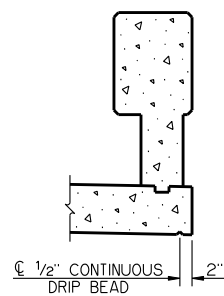

DETAIL "B"

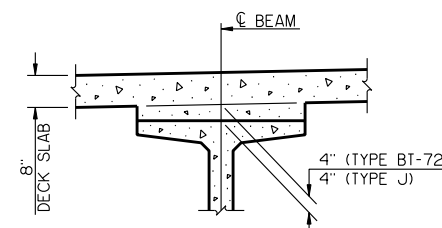

DETAIL OF HAUNCH

PLAN QUANTITIES FOR "CLASS AA CONCRETE" INCLUDE HAUNCHES OVER BEAMS. HAUNCH HEIGHT SHOWN IS AT CENTERLINE BEARING ONLY, MEASURED FROM BOTTOM OF DECK SLAB TO TOP OF BEAM, AND VARIES ACROSS THE SPAN. HAUNCH HEIGHT TO BE DETERMINED AFTER ERECTION OF BEAMS TO PROVIDE FOR DEAD LOAD DEFLECTION AND GRADE ADJUSTMENT, BUT THE PAY QUANTITY WILL BE AS SHOWN IN THE PLANS.

STRUCTURAL STEEL FOR DIAPHRAGM RODS AND PLATE WASHERS SHALL CONFORM TO AASHTO M 270 (ASTM A 709), GRADE 50W, WEATHERING STEEL (CHARPY V-NOTCH TESTING NOT REQUIRED). A #10 REINFORCING STEEL BAR CONFORMING TO AASHTO M 31, GRADE 60 AND THREADED AT BOTH ENDS AS SHOWN MAY BE SUBSTITUTED FOR THE DIAPHRAGM ROD. HEX NUTS SHALL CONFORM TO AASHTO M 291 (ASTM A 563), PROPERTY CLASS 8S3 OR 10S3. PAINT EXPOSED PARTS OF DIAPHRAGM RODS, PLATE WASHERS AND HEX NUTS WITH TWO (2) COATS OF ZINC-RICH PAINT (6 MIL MINIMUM THICKNESS) AFTER ASSEMBLY. ALL COST OF DIAPHRAGM RODS, PLATE WASHERS AND HEX NUTS SHALL BE INCLUDED IN UNIT PRICE BID PER POUND OF "STRUCTURAL STEEL."

APPROVED BY BRIDGE ENGINEER *Robert J. Dush* DATE 9-9-2011

OKLAHOMA DEPARTMENT OF TRANSPORTATION
COUNTY BRIDGE STANDARD (ENGLISH)

TYPICAL CROSS SECTION
TYPE BT-72 AND TYPE J P.C. BEAMS

26' CLEAR ROADWAY - CONVENTIONAL - SKEWED 0°

2009 SPECIFICATIONS CB26-C-SKO-XSECT-PCS 01E CB-165E