

DESCRIPTION	REVISIONS	DATE

SECTION ① DIMENSIONS			REINFORCING STEEL									
S	H	UA	CS1-#5 AT 6" MAX		CS2-#5 AT 6" MAX		CS3-#5 BARS		CT1-#4 AT 12"			
			QTY	LENGTH	QTY	"M"	LENGTH	QTY	"M"	LENGTH	QTY	LENGTH
4'	3'	8"	66	7'-9"	66	6'-3"	8'-8"	4	6'-3"	7'-7"	12	34'-3"
4'	4'	10"	76	7'-9"	76	6'-5"	8'-10"	4	6'-5"	7'-9"	12	39'-5"
5'	3'	8"	70	7'-9"	70	6'-3"	8'-8"	4	6'-3"	7'-7"	12	36'-6"
5'	4'	10"	81	7'-9"	81	6'-5"	8'-10"	4	6'-5"	7'-9"	12	41'-9"
5'	5'	10"	92	7'-9"	92	6'-5"	8'-10"	4	6'-5"	7'-9"	12	47'-5"
6'	3'	8"	75	7'-9"	75	6'-3"	8'-8"	4	6'-3"	7'-7"	12	38'-10"
6'	4'	10"	85	7'-9"	85	6'-5"	8'-10"	4	6'-5"	7'-9"	12	44'-0"
6'	5'	10"	97	7'-9"	97	6'-5"	8'-10"	4	6'-5"	7'-9"	12	49'-9"
6'	6'	11"	108	7'-9"	108	6'-6"	8'-11"	4	6'-6"	7'-10"	12	55'-1"
8'	3'	8"	84	7'-9"	84	6'-3"	8'-8"	4	6'-3"	7'-7"	12	43'-5"
8'	4'	10"	95	7'-9"	95	6'-5"	8'-10"	4	6'-5"	7'-9"	12	48'-8"
8'	5'	10"	106	7'-9"	106	6'-5"	8'-10"	4	6'-5"	7'-9"	12	54'-4"
8'	6'	11"	117	7'-9"	117	6'-6"	8'-11"	4	6'-6"	7'-10"	12	59'-9"
8'	7'	11"	127	7'-9"	127	6'-6"	8'-11"	4	6'-6"	7'-10"	12	67'-5" ③
8'	8'	12"	138	7'-9"	138	6'-7"	9'-0"	4	6'-7"	7'-11"	12	72'-8" ③
10'	3'	8"	94	7'-9"	94	6'-3"	8'-8"	4	6'-3"	7'-7"	12	48'-1"
10'	4'	10"	104	7'-9"	104	6'-5"	8'-10"	4	6'-5"	7'-9"	12	53'-3"
10'	5'	10"	116	7'-9"	116	6'-5"	8'-10"	4	6'-5"	7'-9"	12	59'-1"
10'	6'	11"	126	7'-9"	126	6'-6"	8'-11"	4	6'-6"	7'-10"	12	66'-10" ③
10'	7'	11"	136	7'-9"	136	6'-6"	8'-11"	4	6'-6"	7'-10"	12	72'-1" ③
10'	8'	12"	147	7'-9"	147	6'-7"	9'-0"	4	6'-7"	7'-11"	12	77'-3" ③
10'	9'	13"	158	7'-9"	158	6'-8"	9'-1"	4	6'-8"	8'-0"	12	82'-11" ③
10'	10'	13"	169	7'-9"	169	6'-8"	9'-1"	4	6'-8"	8'-0"	12	88'-2" ③
12'	6'	11"	135	7'-9"	135	6'-6"	8'-11"	4	6'-6"	7'-10"	12	71'-6" ③
12'	7'	11"	146	7'-9"	146	6'-6"	8'-11"	4	6'-6"	7'-10"	12	76'-8" ③
12'	8'	12"	156	7'-9"	156	6'-7"	9'-0"	4	6'-7"	7'-11"	12	81'-10" ③
12'	9'	13"	168	7'-9"	168	6'-8"	9'-1"	4	6'-8"	8'-0"	12	87'-7" ③
12'	10'	13"	178	7'-9"	178	6'-8"	9'-1"	4	6'-8"	8'-0"	12	92'-9" ③
12'	11'	14"	188	7'-9"	188	6'-9"	9'-2"	4	6'-9"	8'-1"	12	97'-11" ③
12'	12'	14"	199	7'-9"	199	6'-9"	9'-2"	4	6'-9"	8'-1"	12	103'-2" ③
14'	7'	11"	155	7'-9"	155	6'-6"	8'-11"	4	6'-6"	7'-10"	12	81'-3" ③
14'	8'	12"	165	7'-9"	165	6'-7"	9'-0"	4	6'-7"	7'-11"	12	86'-6" ③
14'	9'	13"	177	7'-9"	177	6'-8"	9'-1"	4	6'-8"	8'-0"	12	92'-2" ③
14'	10'	13"	187	7'-9"	187	6'-8"	9'-1"	4	6'-8"	8'-0"	12	97'-5" ③
14'	11'	14"	198	7'-9"	198	6'-9"	9'-2"	4	6'-9"	8'-1"	12	102'-7" ③
14'	12'	14"	208	7'-9"	208	6'-9"	9'-2"	4	6'-9"	8'-1"	12	107'-9" ③
16'	8'	12"	175	7'-9"	175	6'-7"	9'-0"	4	6'-7"	7'-11"	12	91'-1" ③
16'	9'	13"	186	7'-9"	186	6'-8"	9'-1"	4	6'-8"	8'-0"	12	96'-10" ③
16'	10'	13"	196	7'-9"	196	6'-8"	9'-1"	4	6'-8"	8'-0"	12	102'-0" ③
16'	11'	14"	207	7'-9"	207	6'-9"	9'-2"	4	6'-9"	8'-1"	12	107'-2" ③
16'	12'	14"	217	7'-9"	217	6'-9"	9'-2"	4	6'-9"	8'-1"	12	112'-5" ③
16'	15'	16"	250	7'-9"	250	6'-11"	9'-4"	4	6'-11"	8'-3"	12	131'-3" ④
18'	9'	13"	195	7'-9"	195	6'-8"	9'-1"	4	6'-8"	8'-0"	12	101'-5" ③
18'	10'	13"	206	7'-9"	206	6'-8"	9'-1"	4	6'-8"	8'-0"	12	106'-7" ③
18'	11'	14"	216	7'-9"	216	6'-9"	9'-2"	4	6'-9"	8'-1"	12	111'-10" ③
18'	12'	14"	226	7'-9"	226	6'-9"	9'-2"	4	6'-9"	8'-1"	12	117'-0" ③
18'	15'	16"	259	7'-9"	259	6'-11"	9'-4"	4	6'-11"	8'-3"	12	135'-10" ④
20'	10'	13"	215	7'-9"	215	6'-8"	9'-1"	4	6'-8"	8'-0"	12	111'-3" ③
20'	11'	14"	225	7'-9"	225	6'-9"	9'-2"	4	6'-9"	8'-1"	12	116'-5" ③
20'	12'	14"	236	7'-9"	236	6'-9"	9'-2"	4	6'-9"	8'-1"	12	124'-2" ④
20'	15'	16"	268	7'-9"	268	6'-11"	9'-4"	4	6'-11"	8'-3"	12	140'-6" ④
20'	17'	20"	291	7'-9"	291	7'-3"	9'-8"	4	7'-3"	8'-7"	12	151'-7" ④

QUANTITIES	
CONC. (C.Y.)	REINF. (LB.)
7.70	1440.00
8.90	1670.00
8.20	1530.00
9.40	1770.00
10.70	2010.00
8.80	1630.00
9.90	1860.00
11.20	2110.00
12.40	2360.00
9.80	1820.00
10.90	2070.00
12.20	2310.00
13.40	2550.00
14.60	2790.00
15.70	3030.00
10.80	2030.00
12.00	2260.00
13.30	2520.00
14.40	2760.00
15.60	2980.00
16.70	3230.00
18.00	3480.00
19.20	3710.00
15.50	2960.00
16.60	3190.00
17.80	3420.00
19.00	3690.00
20.20	3910.00
21.30	4140.00
22.50	4380.00
17.60	3380.00
18.80	3610.00
20.10	3880.00
21.20	4100.00
22.40	4350.00
23.50	4570.00
19.80	3830.00
21.10	4080.00
22.20	4300.00
23.40	4550.00
24.50	4770.00
28.20	5550.00
22.10	4270.00
23.30	4510.00
24.40	4750.00
25.60	4960.00
29.20	5740.00
24.30	4700.00
25.40	4940.00
26.60	5200.00
30.20	5940.00
32.70	6540.00

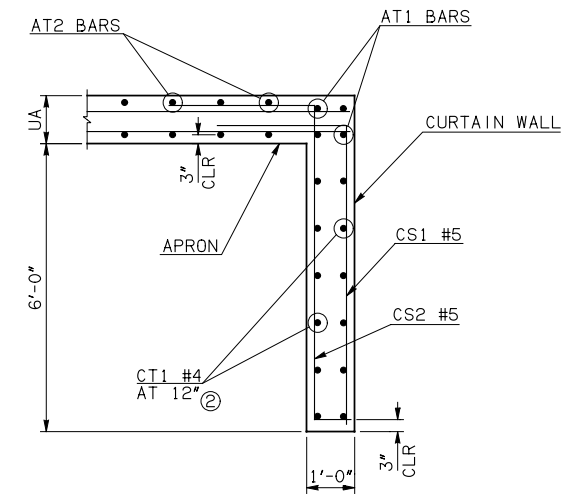

**CURTAIN WALL DETAIL**

- NOTE: ① SEE RCB CULVERTS - BARREL DETAILS FOR ADDITIONAL INFORMATION  
 ② NUMBER & SPACING OF CT1 BARS SHOWN IN DETAIL MAY NOT BE REPRESENTATIVE OF ACTUAL CURTAIN WALL SECTION. SEE SCHEDULE FOR NUMBER AND SPACING OF CT1 BARS.  
 ③ INCLUDES 2'-6" LAPS  
 ④ INCLUDES TWO 2'-6" LAPS

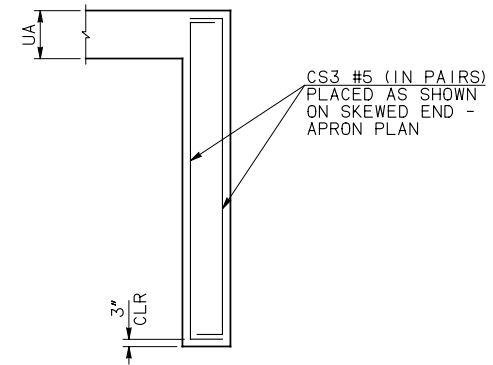

**CURTAIN WALL END DETAIL**

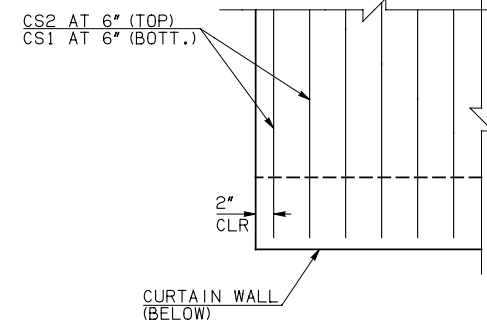

**CURTAIN WALL AT STRAIGHT END-APRON PLAN**

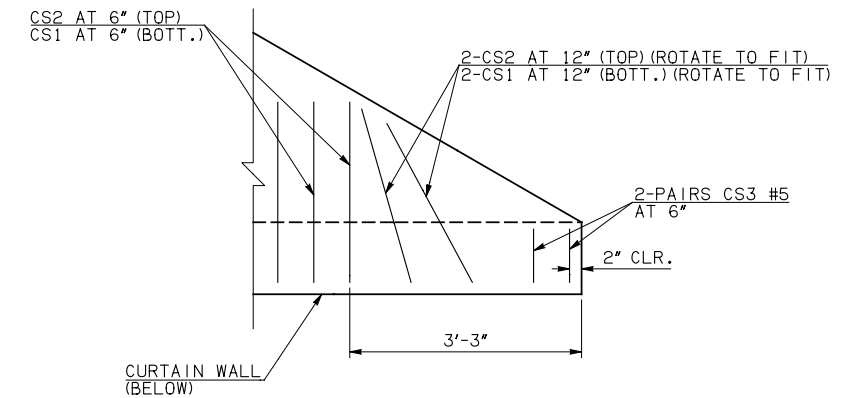

**CURTAIN WALL AT SKEWED END-APRON PLAN**

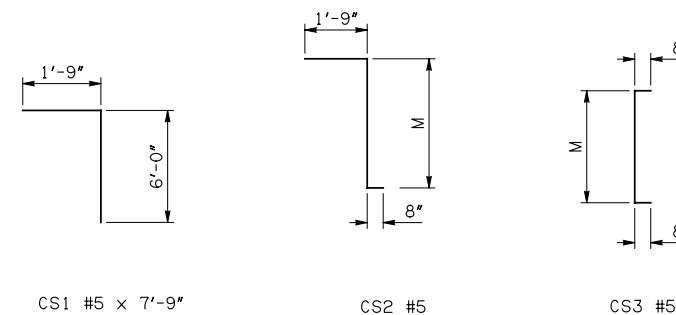

APPROVED BY BRIDGE ENGINEER *Robert J. Muehl* DATE 4/09/09

**OKLAHOMA DEPT. OF TRANSPORTATION  
 BRIDGE STANDARD (ENGLISH)**

**RCB CULVERTS - CURTAIN WALL DETAILS  
 DOUBLE CELL - 6'-0" DEPTH - 30°**

1999 SPECIFICATIONS RCB-CW2-D6-30 OOE  
 B-826E