

DESCRIPTION	REVISIONS	DATE

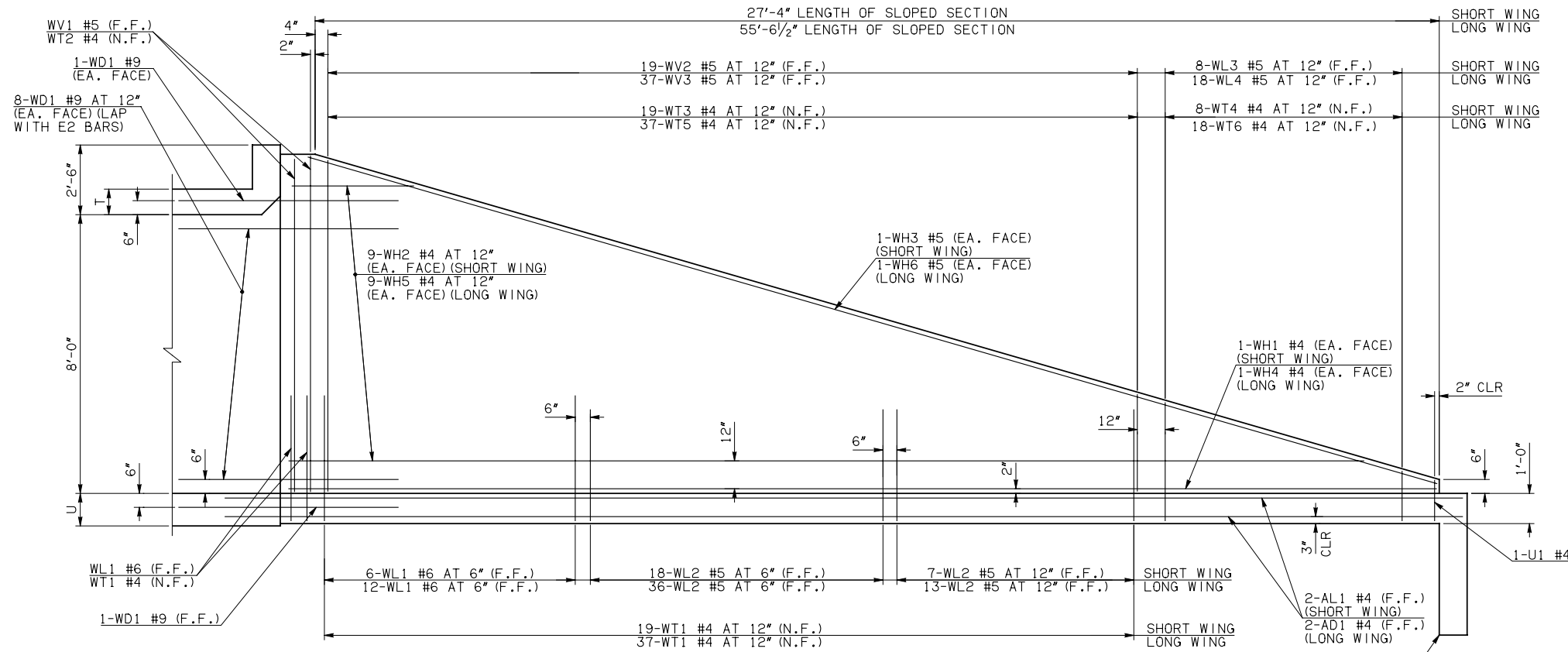

NOTE: F.F. = FAR FACE
N.F. = NEAR FACE

WING ELEVATION

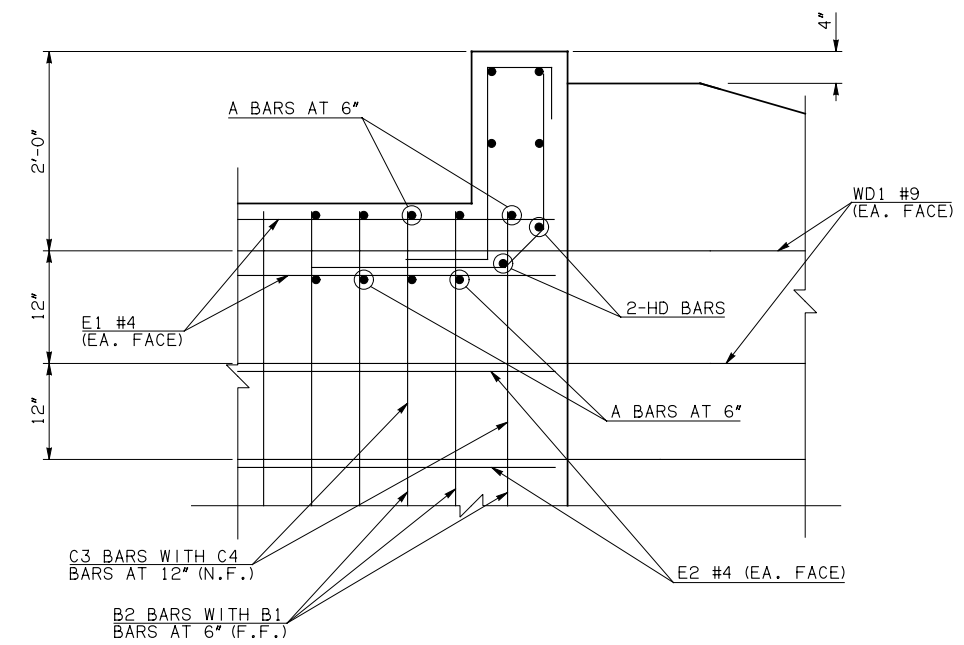

③ HEADWALL DETAIL AT EXTERIOR WALL

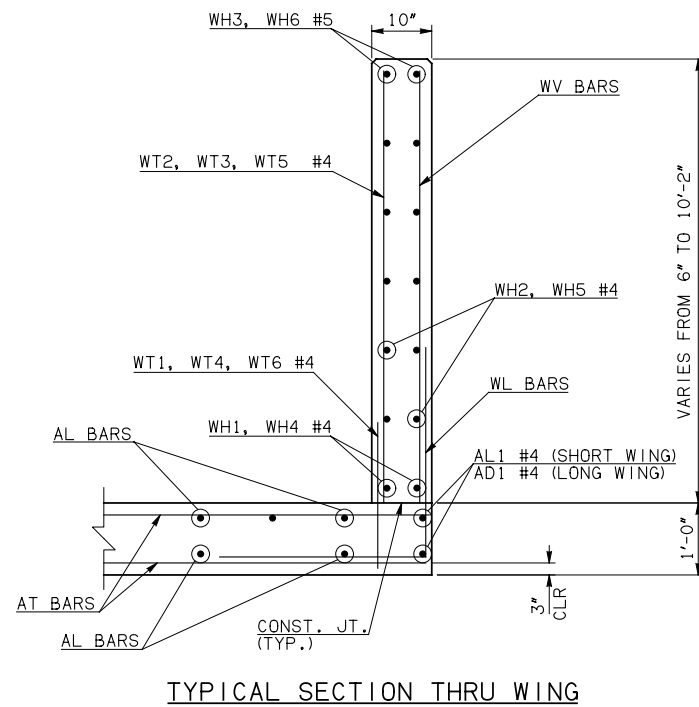

TYPICAL SECTION THRU WING

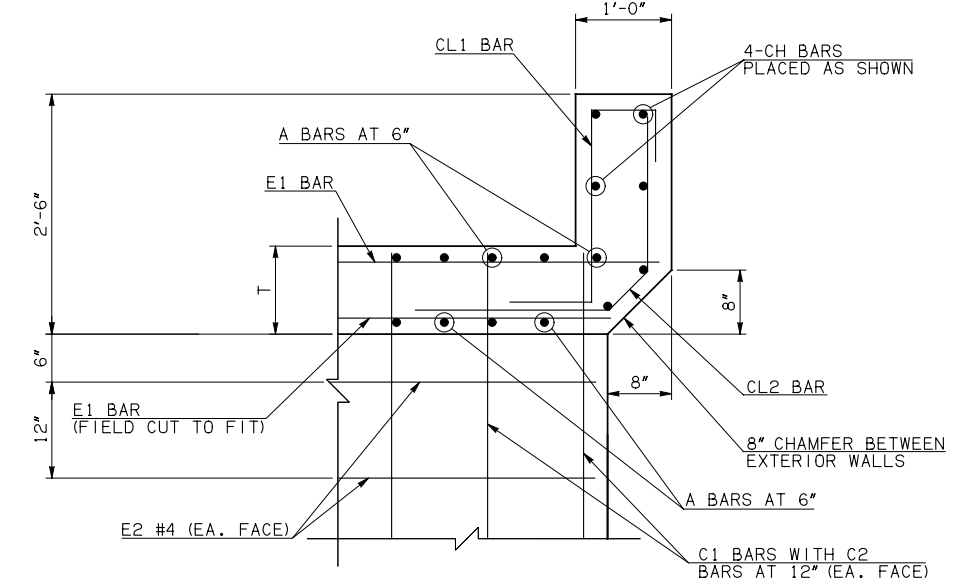
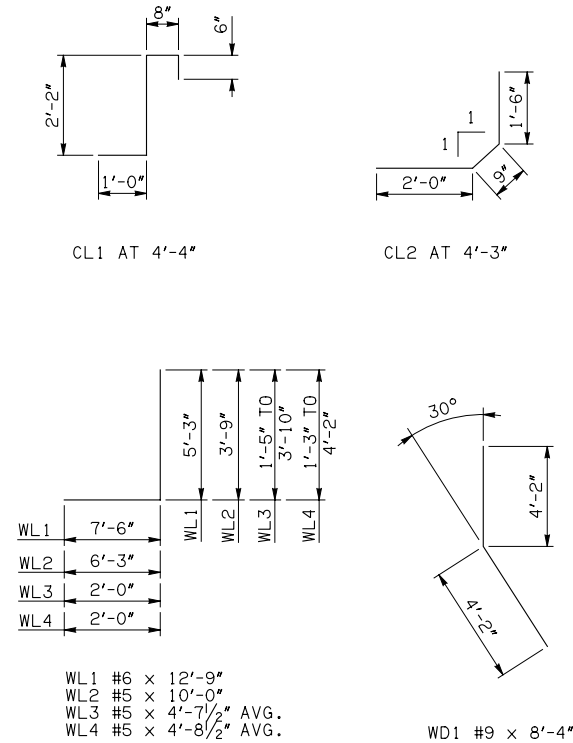

③ HEADWALL DETAIL AT INTERIOR WALL
DIMENSION SHOWN NORMAL TO HEADWALL

NOTES:

- ② QUANTITY SHOWN REPRESENTS TWO SETS.
- ③ FOR FURTHER INFORMATION REGARDING END SECTION BARS A, B, C, E1, AND E2, REFER TO RCB CULVERTS - BARREL DETAILS.

WINGWALL BAR LIST (LONG AND SHORT WING INCLUDED)					
MARK	SIZE	QTY.	FORM	LENGTH	REMARKS
WD1	#9	38	BNT	8'-4"	
WH1	#4	2	STR	28'-4"	
WH2	#4	18	STR	14'-9" AVG.	3'-5" TO 26'-1"
WH3	#5	2	STR	28'-9"	
WH4	#4	2	STR	56'-6"	
WH5	#4	18	STR	28'-10" AVG.	5'-10" TO 51'-10"
WH6	#5	2	STR	56'-2"	
WL1	#6	22	BNT	12'-9"	
WL2	#5	74	BNT	10'-0"	
WL3	#5	8	BNT	4'-7 1/2" AVG.	3'-5" TO 5'-10"
WL4	#5	18	BNT	4'-8 1/2" AVG.	3'-3" TO 6'-2"
WT1	#4	61	STR	2'-10"	
WT2	#4	5	STR	10'-0"	
WT3	#4	19	STR	6'-8" AVG.	3'-6" TO 9'-10"
WT4	#4	8	STR	2'-7 1/2" AVG.	1'-5" TO 3'-10"
WT5	#4	37	STR	6'-9 1/2" AVG.	3'-8" TO 9'-11"
WT6	#4	18	STR	2'-8 1/2" AVG.	1'-3" TO 4'-2"
WV1	#5	4	STR	10'-0"	
WV2	#5	19	STR	6'-8" AVG.	3'-6" TO 9'-10"
WV3	#5	37	STR	6'-9 1/2" AVG.	3'-8" TO 9'-11"
U1	#4	2	BNT	2'-8"	

HEADWALL BAR LIST

ONE HEADWALL SHOWN																
MARK	FORM	8' SPAN			10' SPAN			12' SPAN			14' SPAN			16' SPAN		
		SIZE	QTY.	LENGTH	SIZE	QTY.	LENGTH	SIZE	QTY.	LENGTH	SIZE	QTY.	LENGTH	SIZE	QTY.	LENGTH
CH	STR	#4	2	22'-2"	#6	4	26'-9"	#6	4	31'-5"	#6	4	36'-0"	#8	4	40'-10"
CL1	BNT	#4	22	4'-4"	#5	27	4'-4"	#5	32	4'-4"	#5	36	4'-4"	#5	41	4'-4"
CL2	BNT	#4	22	4'-3"	#5	27	4'-3"	#5	32	4'-3"	#5	36	4'-3"	#5	41	4'-3"
HD	STR	#6	2	22'-2"	#8	2	26'-9"	#8	2	31'-5"	#8	2	36'-0"	#9	2	40'-10"

APPROVED BY BRIDGE ENGINEER *Robert J. Muech* DATE 4/09/09

OKLAHOMA DEPT. OF TRANSPORTATION
BRIDGE STANDARD (ENGLISH)
RCB CULVERTS - END SECTION DETAILS
DOUBLE CELL - 8'-0" HEIGHT - 30°
SHEET NO. 3 OF 3