

DESCRIPTION	REVISIONS	DATE

WINGWALL DIMENSIONS			
SPAN	W	D	F
6'	12"	5/4"	5/4"
8'	12"	5/4"	5/4"
10'	12"	5/4"	5/4"
12'	12"	5/4"	5/4"

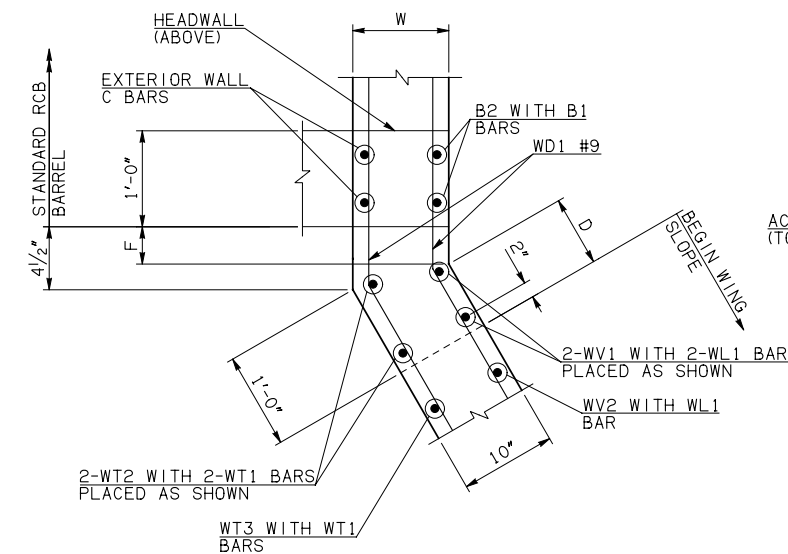
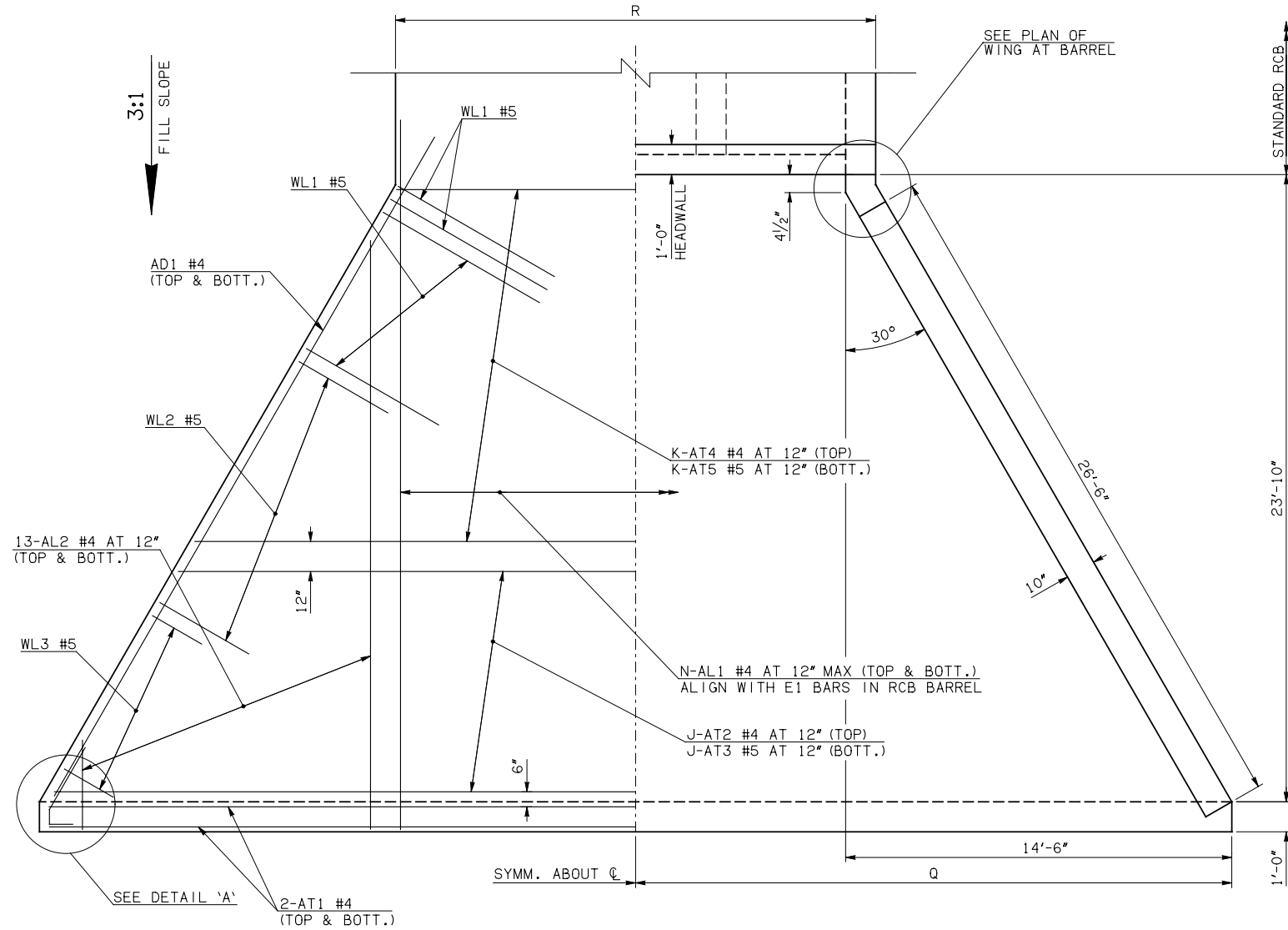

PLAN OF WING AT BARREL

APRON VARIABLES						
SPAN	DIM. R	DIM. Q	QTY. J	QTY. K	QTY. N	
6'	22'-0"	24'-6"	24	0	26	
8'	28'-0"	27'-6"	24	0	32	
10'	34'-0"	30'-6"	1	23	38	
12'	40'-0"	33'-6"	6	18	44	

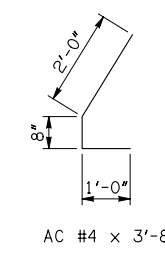

AC #4 x 3'-8"

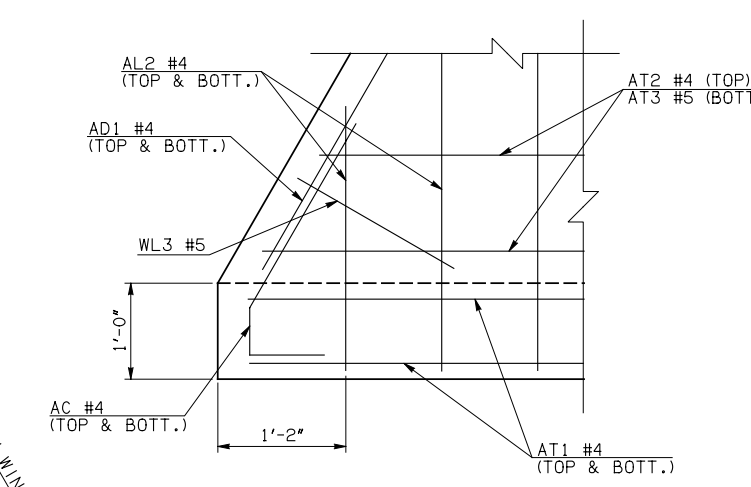

DETAIL 'A'

WINGWALL BAR LIST					
ONE WINGWALL SHOWN; TWO REQUIRED					
MARK	SIZE	QTY.	FORM	LENGTH	REMARKS
WD1	#9	14	BNT	8'-4"	
WH1	#4	2	STR	27'-4"	
WH2	#4	14	STR	14'-2 1/2" AVG.	3'-10" TO 24'-7"
WH3	#5	2	STR	27'-4"	
WL1	#5	16	BNT	8'-6"	
WL2	#5	9	BNT	4'-10"	
WL3	#5	10	BNT	4'-7 1/2" AVG.	3'-4" TO 5'-11"
WT1	#4	18	STR	2'-10"	
WT2	#4	2	STR	8'-0"	
WT3	#4	16	STR	5'-8" AVG.	3'-6" TO 7'-10"
WT4	#4	10	STR	2'-7 1/2" AVG.	1'-4" TO 3'-11"
WV1	#5	2	STR	8'-0"	
WV2	#5	16	STR	5'-8" AVG.	3'-6" TO 7'-10"
U1	#4	1	BNT	2'-6"	

- ① 4-SETS OF 13-AL2 BARS REQUIRED
- ② 2-SETS OF 7-WH2 BARS REQUIRED
- ③ INCLUDE 2'-6" LAP

APRON AND HEADWALL BAR LIST

APRON AND HEADWALL BAR LIST														
ONE APRON AND ONE HEADWALL SHOWN														
MARK	SIZE	FORM	6' SPAN			8' SPAN			10' SPAN			12' SPAN		
			QTY.	LENGTH	REMARKS	QTY.	LENGTH	REMARKS	QTY.	LENGTH	REMARKS	QTY.	LENGTH	REMARKS
AC	#4	BNT	4	3'-8"		4	3'-8"		4	3'-8"		4	3'-8"	
AD1	#4	STR	4	29'-4"		4	29'-4"		4	29'-4"		4	29'-4"	
AL1	#4	STR	52	26'-7"		64	26'-7"		76	26'-7"		88	26'-7"	
AL2	#4	STR	52	12'-10 1/2" AVG.	2'-6" TO 23'-3"	52	12'-10 1/2" AVG.	2'-6" TO 23'-3"	52	12'-10 1/2" AVG.	2'-6" TO 23'-3"	52	12'-10 1/2" AVG.	2'-6" TO 23'-3"
AT1	#4	STR	4	48'-8"		4	54'-8"		4	63'-2" ③		4	69'-2" ③	
AT2	#4	STR	24	34'-10 1/2" AVG.	21'-7" TO 48'-2"	24	40'-10 1/2" AVG.	27'-7" TO 54'-2"	1	62'-8" ③		6	65'-9" AVG.	62'-10" TO 68'-8" ③
AT3	#5	STR	24	34'-10 1/2" AVG.	21'-7" TO 48'-2"	24	40'-10 1/2" AVG.	27'-7" TO 54'-2"	1	62'-8" ③		6	65'-9" AVG.	62'-10" TO 68'-8" ③
AT4	#4	STR	0			0			23	46'-3 1/2" AVG.	33'-7" TO 59'-0"	18	49'-4 1/2" AVG.	39'-7" TO 59'-2"
AT5	#5	STR	0			0			23	46'-3 1/2" AVG.	33'-7" TO 59'-0"	18	49'-4 1/2" AVG.	39'-7" TO 59'-2"
CH	#4	STR	4	21'-8"		4	27'-8"		4	33'-8"		4	39'-8"	
CL1	#4	BNT	26	4'-4"		32	4'-4"		38	4'-4"		44	4'-4"	
CL2	#4	BNT	26	4'-3"		32	4'-3"		38	4'-3"		44	4'-3"	

QUANTITIES

ITEM	UNIT	6' SPAN	8' SPAN	10' SPAN	12' SPAN
CLASS AA CONCRETE	CY	38.60	43.90	49.30	54.50
REINFORCING STEEL	LB	5490.00	6060.00	6600.00	7170.00

NOTE: QUANTITIES ABOVE ARE FOR ONE END SECTION, WHICH IS COMPRISED OF ONE HEADWALL, ONE APRON, AND TWO WINGWALLS. INCLUDED IN REINFORCING STEEL PAY ITEM QUANTITY IS THE WEIGHT OF ADDITIONAL RCB BARREL REINFORCING STEEL REQUIRED AS SHOWN.

APPROVED BY BRIDGE ENGINEER *Robert J. Nusch* DATE 4/09/09

OKLAHOMA DEPT. OF TRANSPORTATION
BRIDGE STANDARD (ENGLISH)
RCB CULVERTS - END SECTION DETAILS
TRIPLE CELL - 6'-0" HEIGHT - 0°
SHEET NO. 1 OF 2

1999 SPECIFICATIONS	RCB-E3-H6-0-1	OOE
---------------------	---------------	-----

B-634E