

DESCRIPTION	REVISIONS	DATE

WINGWALL DIMENSIONS			
SPAN	W	D	F
10'	12"	8 3/4"	0
12'	12"	8 3/4"	0
14'	13"	6 3/4"	1 3/4"
16'	14"	4 3/4"	3 1/2"
18'	15"	2 3/4"	5 1/4"
20'	15"	2 3/4"	5 1/4"

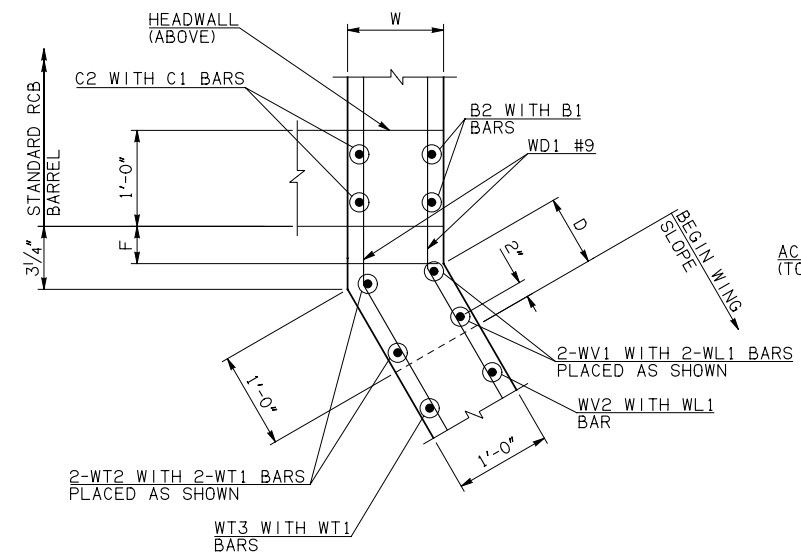

APRON VARIABLES						
SPAN	DIM. R	DIM. Q	QTY. J	QTY. K	QTY. N	
10'	12'-0"	26'-7"	36	0	14	
12'	14'-0"	27'-7"	36	0	16	
14'	16'-2"	28'-7"	36	0	18	
16'	18'-4"	29'-7"	36	0	20	
18'	20'-6"	30'-7"	1	35	22	
20'	22'-6"	31'-7"	3	33	24	

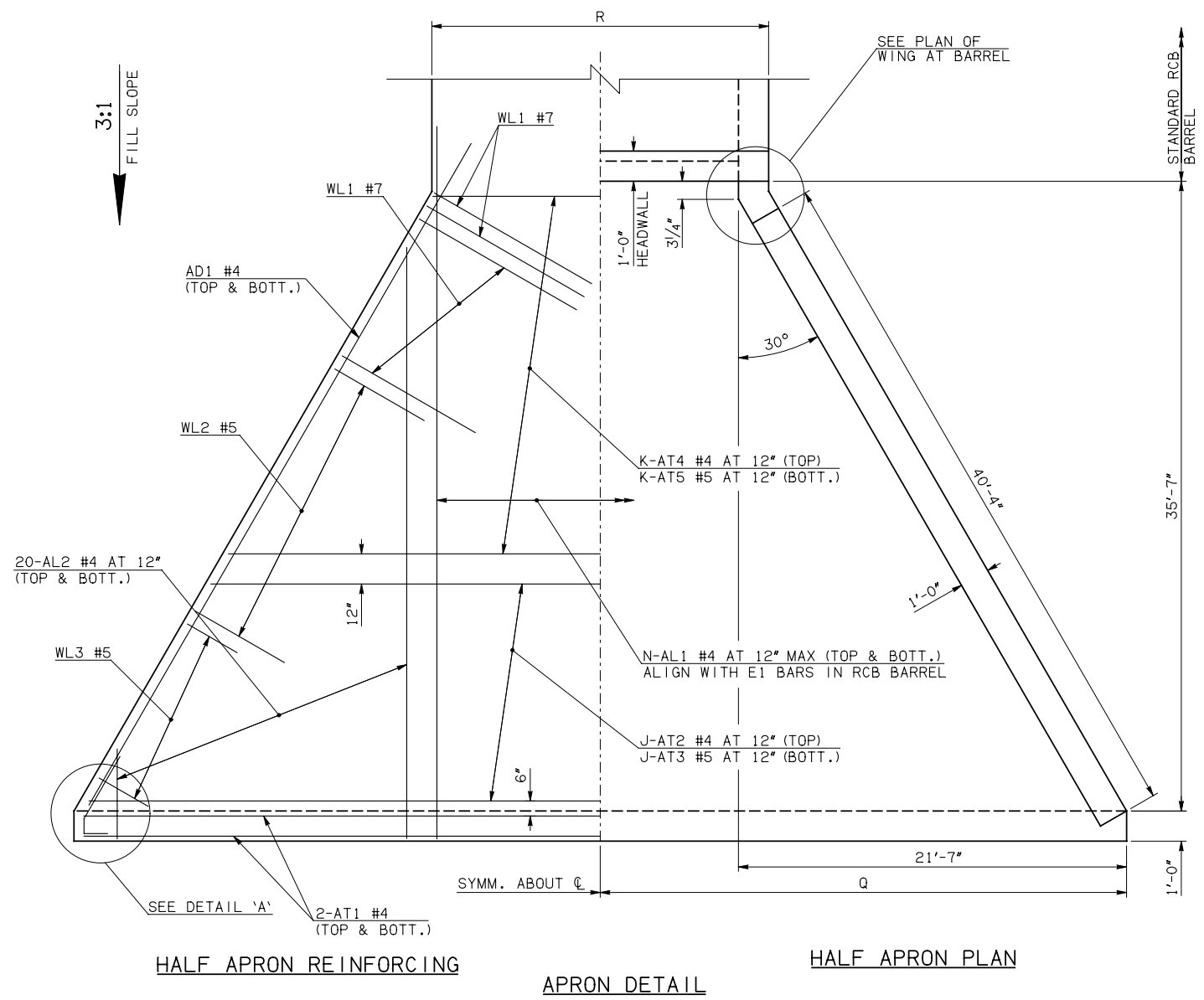
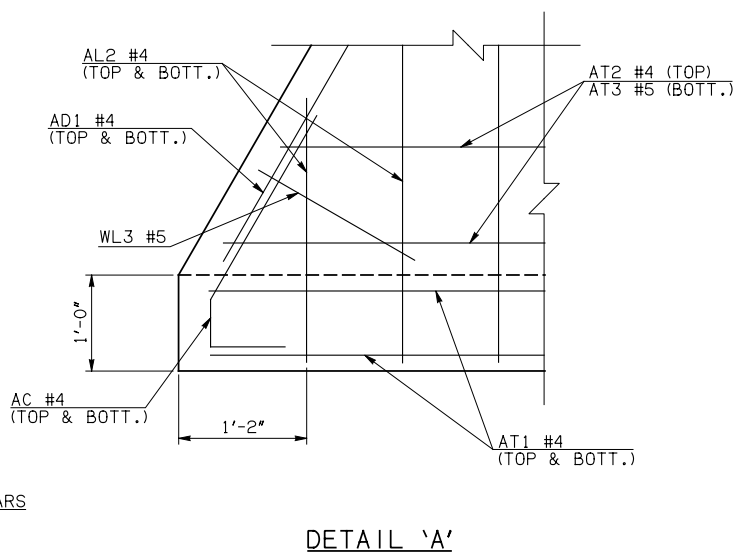

WINGWALL BAR LIST					
ONE WINGWALL SHOWN; TWO REQUIRED					
MARK	SIZE	QTY.	FORM	REMARKS	
WD1	#9	22	BNT	8'-4"	
WH1	#4	2	STR	41'-2"	
② WH2	#4	22	STR	21'-1 1/2" AVG.	3'-10" TO 38'-5"
WH3	#5	2	STR	41'-9"	
WL1	#7	21	BNT	14'-5"	
WL2	#5	31	BNT	10'-3"	
WL3	#5	10	BNT	4'-8 1/2" AVG.	3'-5" TO 6'-0"
WT1	#4	32	STR	2'-10"	
WT2	#4	2	STR	12'-0"	
WT3	#4	10	STR	10'-6 1/2" AVG.	9'-3" TO 11'-10"
WT4	#4	20	STR	6'-3" AVG.	3'-6" TO 9'-0"
WT5	#4	10	STR	2'-8 1/2" AVG.	1'-5" TO 4'-0"
WV1	#5	2	STR	12'-0"	
WV2	#5	19	STR	10'-6 1/2" AVG.	9'-3" TO 11'-10"
WV3	#5	20	STR	6'-3" AVG.	3'-6" TO 9'-0"
U1	#4	1	BNT	3'-0"	

APRON AND HEADWALL BAR LIST																					
ONE APRON AND ONE HEADWALL SHOWN																					
MARK	SIZE	FORM	10' SPAN			12' SPAN			14' SPAN			16' SPAN			18' SPAN			20' SPAN			
			QTY.	LENGTH	REMARKS	QTY.	LENGTH	REMARKS	QTY.	LENGTH	REMARKS	QTY.	LENGTH	REMARKS	QTY.	LENGTH	REMARKS	QTY.	LENGTH	REMARKS	
AC	#4	BNT	4	3'-8"		4	3'-8"		4	3'-8"		4	3'-8"		4	3'-8"		4	3'-8"		
AD1	#4	STR	4	43'-2"		4	43'-2"		4	43'-2"		4	43'-2"		4	43'-2"		4	43'-2"		
AL1	#4	STR	28	38'-5"		32	38'-5"		36	38'-5"		40	38'-5"		44	38'-5"		48	38'-5"		
① AL2	#4	STR	80	18'-11 1/2" AVG.	2'-6" TO 35'-5"	80	18'-11 1/2" AVG.	2'-6" TO 35'-5"	80	18'-11 1/2" AVG.	2'-6" TO 35'-5"	80	18'-11 1/2" AVG.	2'-6" TO 35'-5"	80	18'-11 1/2" AVG.	2'-6" TO 35'-5"	80	18'-11 1/2" AVG.	2'-6" TO 35'-5"	
AT1	#4	STR	4	52'-10"		4	54'-10"		4	56'-10"		4	58'-10"		4	63'-4"	③	4	65'-4"	③	
AT2	#4	STR	36	32'-1 1/2" AVG.	11'-11" TO 52'-4"	36	34'-1 1/2" AVG.	13'-11" TO 54'-4"	36	36'-1 1/2" AVG.	15'-11" TO 56'-4"	36	38'-1 1/2" AVG.	17'-11" TO 58'-4"	1	62'-10"	③	3	63'-8" AVG.	62'-6" TO 64'-10"	③
AT3	#5	STR	36	32'-1 1/2" AVG.	11'-11" TO 52'-4"	36	34'-1 1/2" AVG.	13'-11" TO 54'-4"	36	36'-1 1/2" AVG.	15'-11" TO 56'-4"	36	38'-1 1/2" AVG.	17'-11" TO 58'-4"	1	62'-10"	③	3	63'-8" AVG.	62'-6" TO 64'-10"	③
AT4	#4	STR	0			0			0			0			35	39'-6 1/2" AVG.	19'-11" TO 59'-2"	33	40'-4 1/2" AVG.	21'-11" TO 58'-10"	
AT5	#5	STR	0			0			0			0			35	39'-6 1/2" AVG.	19'-11" TO 59'-2"	33	40'-4 1/2" AVG.	21'-11" TO 58'-10"	
CH	#4	STR	4	11'-8"		4	13'-8"		4	15'-10"		4	18'-0"		4	20'-2"		4	22'-2"		
CL1	#4	BNT	14	4'-4"		16	4'-4"		18	4'-4"		20	4'-4"		22	4'-4"		24	4'-4"		
CL2	#4	BNT	14	4'-3"		16	4'-3"		18	4'-3"		20	4'-3"		22	4'-3"		24	4'-3"		

- ① 4-SETS OF 20-AL2 BARS REQUIRED
- ② 2-SETS OF 11-WH2 BARS REQUIRED
- ③ INCLUDES 2'-6" LAP

QUANTITIES							
ITEM	UNIT	10' SPAN	12' SPAN	14' SPAN	16' SPAN	18' SPAN	20' SPAN
CLASS AA CONCRETE	CY	69.00	72.00	75.00	77.90	80.90	83.80
REINFORCING STEEL	LB	9520.00	9770.00	10010.00	10260.00	10520.00	10770.00

NOTE: QUANTITIES ABOVE ARE FOR ONE END SECTION, WHICH IS COMPRISED OF ONE HEADWALL, ONE APRON, AND TWO WINGWALLS. INCLUDED IN REINFORCING STEEL PAY ITEM QUANTITY IS THE WEIGHT OF ADDITIONAL RCB BARREL REINFORCING STEEL REQUIRED AS SHOWN.

APPROVED BY BRIDGE ENGINEER *Robert J. Misch* DATE 4/09/09

OKLAHOMA DEPT. OF TRANSPORTATION
BRIDGE STANDARD (ENGLISH)
RCB CULVERTS - END SECTION DETAILS
SINGLE CELL - 10'-0" HEIGHT - 0°
SHEET NO. 1 OF 2

1999 SPECIFICATIONS	RCB-E1-H10-0-1	OOE
		B-586E