

ENCASED BEAM PLATE DETAILS
 NOTE:
 Encased Beam Plate located at expansion end only.

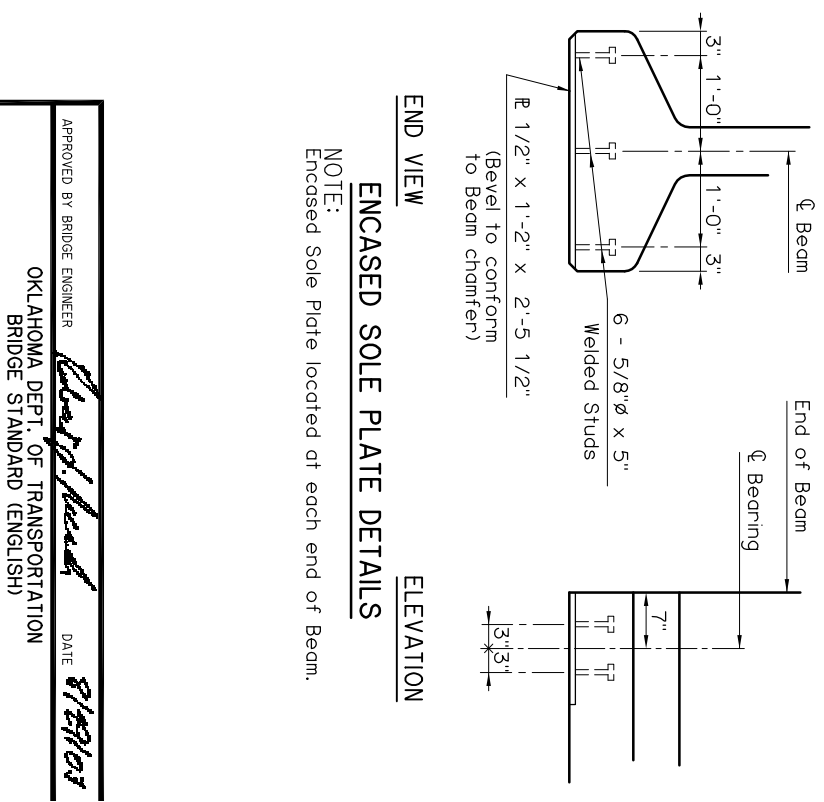
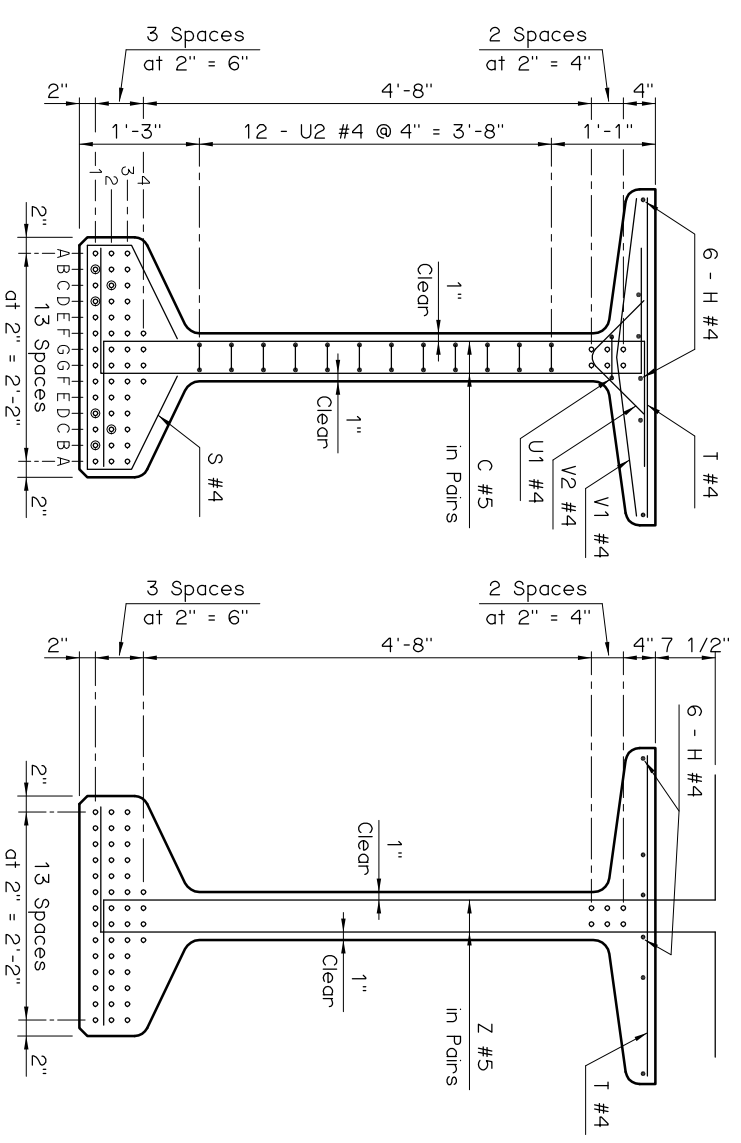

ENCASED SOLE PLATE DETAILS
 NOTE:
 Encased Sole Plate located at each end of Beam.

DEBOND SCHEDULE	
DEBOND PAIR	DEBOND LENGTH FROM END OF BEAM
B1	20'-0"
D1	10'-0"
C2	5'-0"

BEAM SECTIONS
 (32 - 0.6" STRANDS)

APPROVED BY BRIDGE ENGINEER *Chad Head* DATE *8/16/09*
 OKLAHOMA DEPT. OF TRANSPORTATION
 BRIDGE STANDARD (ENGLISH)
 TYPE J P.C. BEAM DETAILS
 125' SPAN
 CONVENTIONAL (SHEET 2 OF 2)
 1999 SPECIFICATIONS B40-C-PCB-J-125-2 OOE
 B-341E