

ENCASED BEAM PLATE DETAILS

NOTE: Encased Beam Plate located at expansion end only.

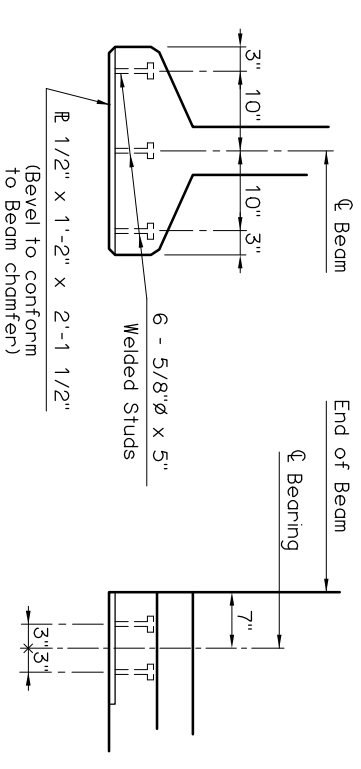
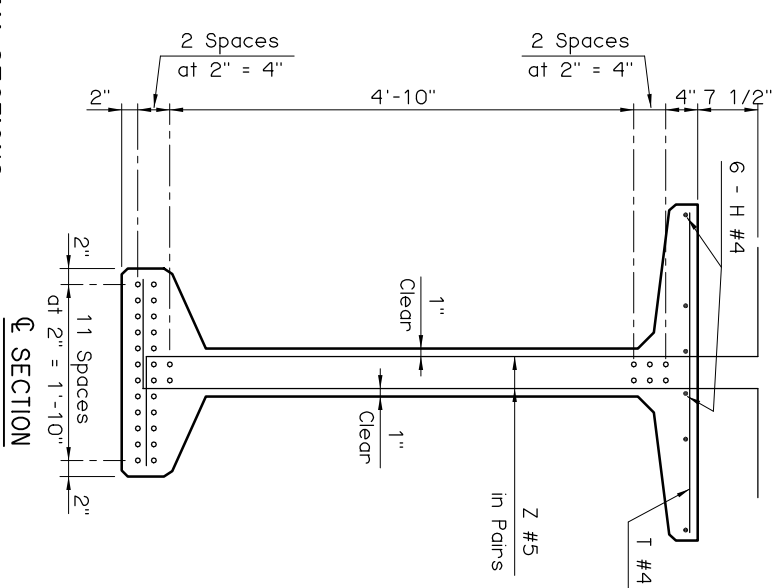
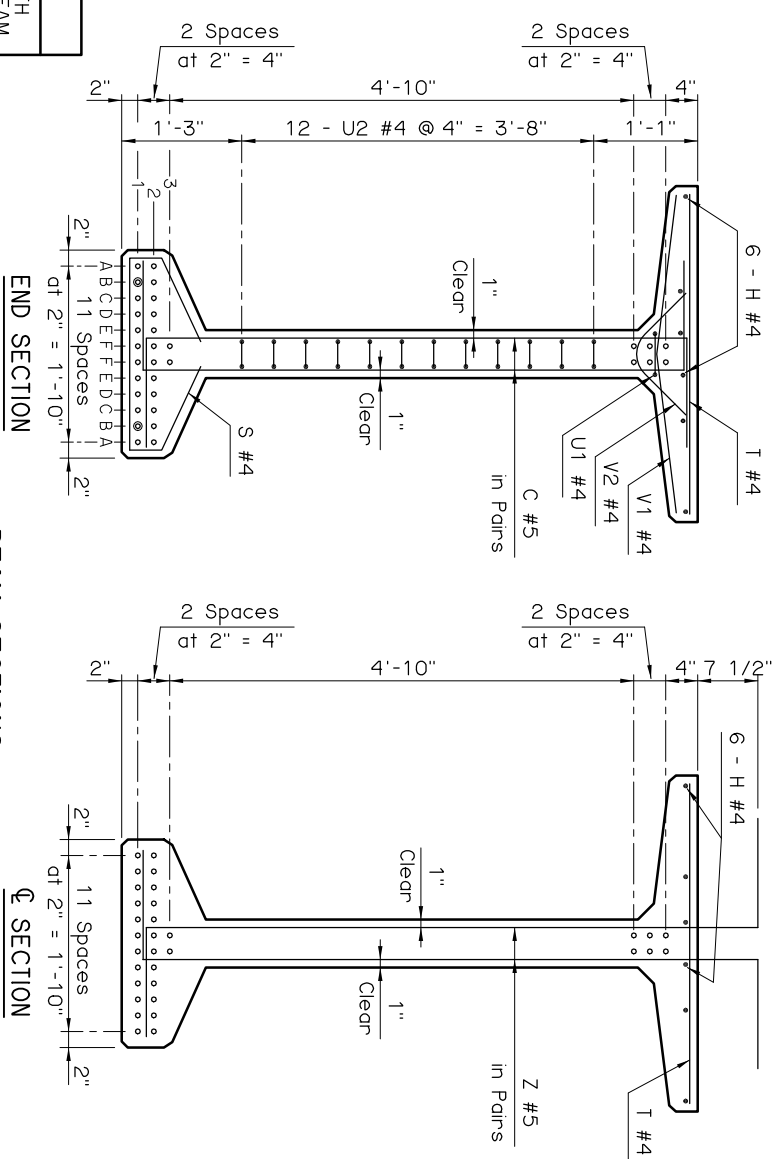

ENCASED SOLE PLATE DETAILS

NOTE: Encased Sole Plate located at each end of Beam.

DEBOND SCHEDULE	
DEBOND PAIR	DEBOND LENGTH FROM END OF BEAM
B1	5'-0"

BEAM SECTIONS
(32 - 0.6"Ø STRANDS)

APPROVED BY BRIDGE ENGINEER *Chad Head* DATE *8/16/09*

OKLAHOMA DEPT. OF TRANSPORTATION
BRIDGE STANDARD (ENGLISH)
TYPE BT-72 P.C. BEAM DETAILS
100' SPAN
CONVENTIONAL (SHEET 2 OF 2)

1999 SPECIFICATIONS B40-C-PCB-BT-100-2 OOE B-319E