

PLAN OF APPROACH SLAB AT BEGIN BRIDGE
 BOTTOM LAYER OF REINFORCING STEEL SHOWN. TYPICAL FOR EACH APPROACH SLAB.

PLAN OF APPROACH SLAB AT END BRIDGE
 TOP LAYER OF REINFORCING STEEL SHOWN. TYPICAL FOR EACH APPROACH SLAB. DO NOT TIE WITHIN 6" OF THE SAWED AND SEALED JOINTS

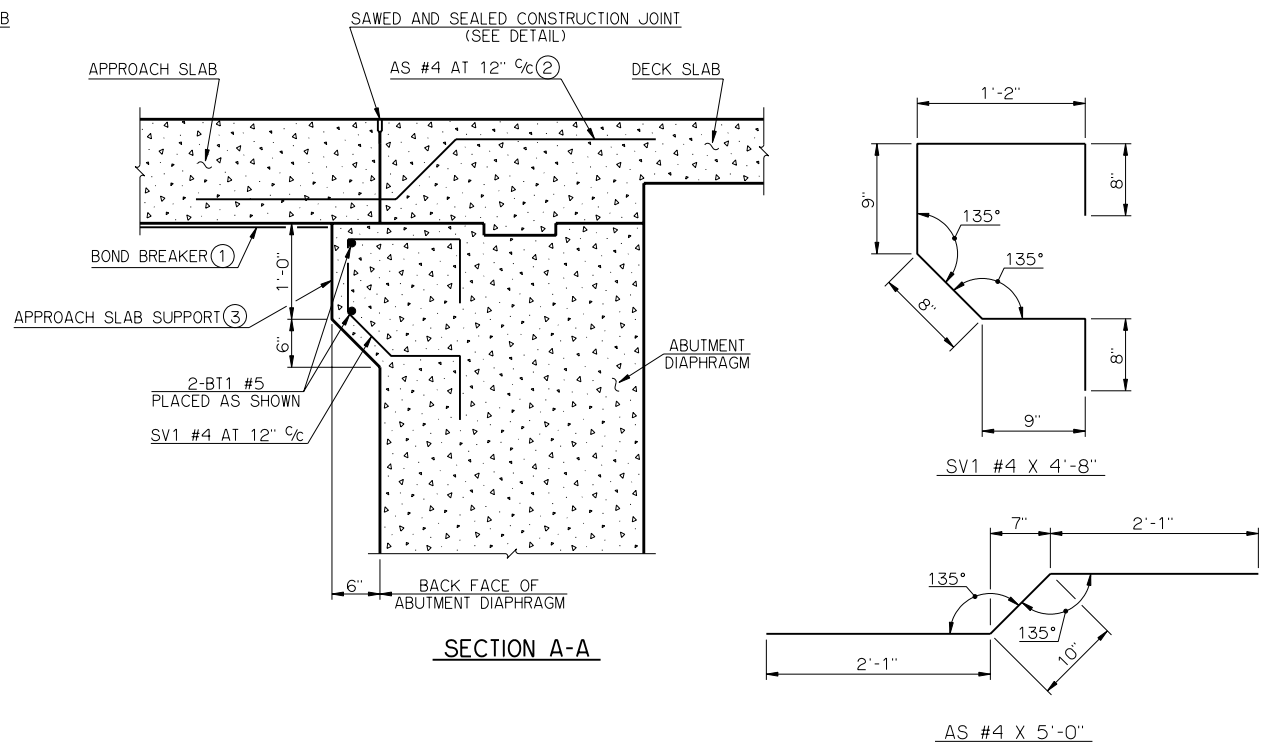

SECTION A-A

DETAILS OF BENT REINFORCING STEEL

| BAR LIST ONE APPROACH SLAB | | | | |
|-------------------------------|-----|------|------|--------|
| MARK | NO. | SIZE | FORM | LENGTH |
| AS | 33 | #4 | BNT. | 5'-0" |
| BL1 | 49 | #9 | STR. | 19'-8" |
| BT1 | 33 | #5 | STR. | 31'-6" |
| SV1 | 33 | #4 | BNT. | 4'-8" |
| TL1 | 34 | #4 | STR. | 19'-8" |
| TT1 | 42 | #4 | STR. | 15'-7" |

SUMMARY OF QUANTITIES - ONE APPROACH SLAB

| ITEM | UNIT | TOTAL |
|-----------------|------|-------|
| ⑤ APPROACH SLAB | SY | 70.80 |

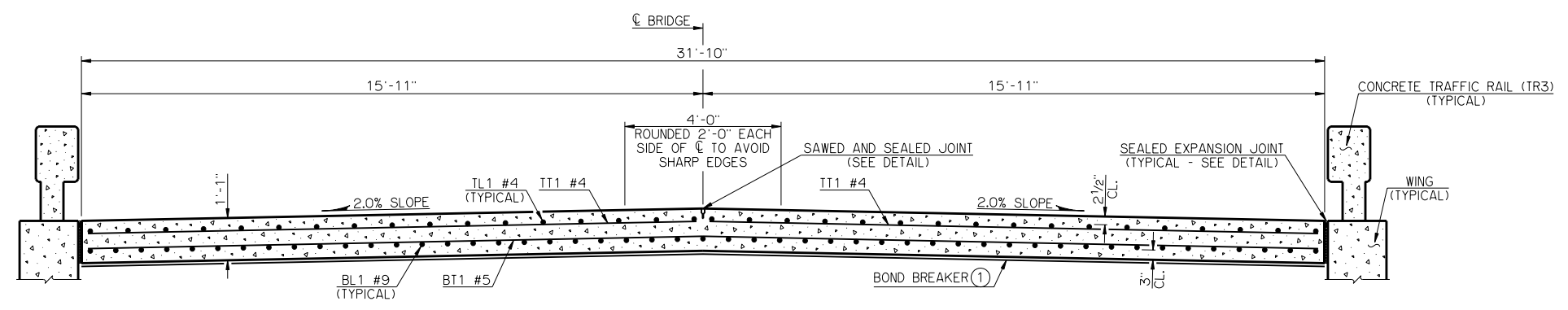

TYPICAL SECTION THRU APPROACH SLAB

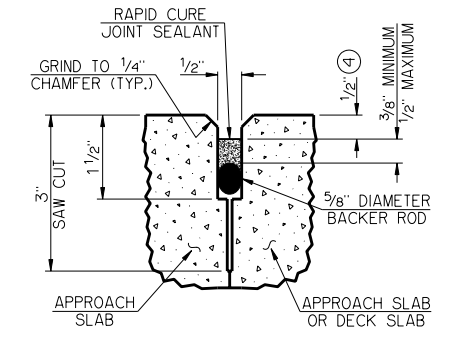

DETAIL OF SAWED AND SEALED JOINT

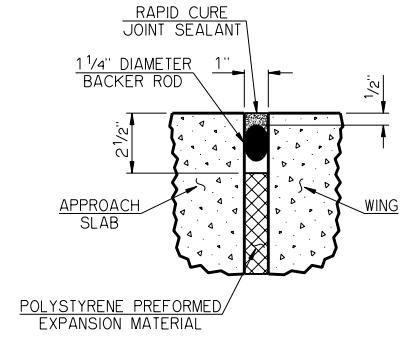

DETAIL OF SEALED EXPANSION JOINT

- THE BOND BREAKER SHALL BE ONE 6 MIL OR TWO 4 MIL POLYETHYLENE SHEETS. THE BOND BREAKER SHALL EXTEND THE FULL WIDTH AND LENGTH OF THE APPROACH SLAB BUT SHALL NOT BE PLACED IN THE NOTCH ABOVE THE APPROACH SLAB SUPPORT AT THE BACK FACE OF THE ABUTMENT DIAPHRAGM.
- AS BARS SHALL BE TIED TO THE TOP LAYER OF REINFORCING STEEL IN THE DECK SLAB AND TO THE BOTTOM LAYER OF REINFORCING STEEL IN THE APPROACH SLAB. AS BARS SHALL BE INSTALLED BEFORE PLACING DECK SLAB CONCRETE.
- THE APPROACH SLAB SUPPORT AT THE BACK FACE OF THE ABUTMENT DIAPHRAGM SHALL BE CONSTRUCTED WITH THE ABUTMENT DIAPHRAGM. SV1 AND BT1 BARS SHALL BE INSTALLED BEFORE PLACING THE ABUTMENT DIAPHRAGM CONCRETE.
- AT TRANSVERSE JOINTS ONLY, THIS DIMENSION SHALL TAPER FROM 1/2" AT THE EDGE OF DRIVING LANES TO 1/8" AT TRAFFIC RAILS
- THE UNIT PRICE BID PER SQUARE YARD OF "APPROACH SLAB" SHALL INCLUDE ALL COST TO CONSTRUCT THE APPROACH SLAB AND THE APPROACH SLAB SUPPORT AT THE BACK FACE OF THE ABUTMENT DIAPHRAGM INCLUDING THE COST OF ALL CONCRETE, ALL REINFORCING STEEL INCLUDING AS, BT1 AND SV1 BARS, BACKER ROD, RAPID CURE JOINT SEALANT, POLYSTYRENE PREFORMED EXPANSION MATERIAL, POLYETHYLENE SHEETING, SAWING, GRINDING, EXCAVATION, BACKFILL, MATERIALS, LABOR, EQUIPMENT AND INCIDENTALS.

APPROVED BY BRIDGE ENGINEER *Robert J. Rusk* DATE 10/16/05
 OKLAHOMA DEPARTMENT OF TRANSPORTATION
 COUNTY BRIDGE STANDARD (ENGLISH)
APPROACH SLAB DETAILS
 32' CLEAR ROADWAY - INTEGRAL - SKEWED 0°
 1999 STANDARD SPECIFICATIONS CB32-I-SKO-AS OOE CB-904E