

**HALF PLAN AT ABUTMENT**  
C1 BARS, Z BARS, STRANDS AND ENCASED PLATES NOT SHOWN

**HALF PLAN AT PIER**  
C1 BARS, Z BARS, STRANDS, ELASTOMERIC PAD AND ENCASED PLATES NOT SHOWN

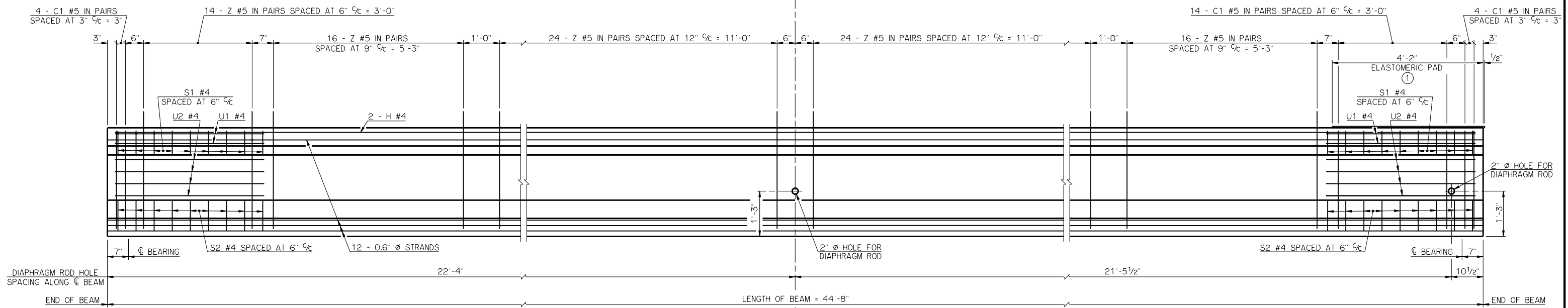

**HALF ELEVATION AT ABUTMENT**  
ENCASED PLATES NOT SHOWN

**HALF ELEVATION AT PIER**  
ENCASED PLATES NOT SHOWN

① ELASTOMERIC PAD SHALL HAVE A 50 DUROMETER HARDNESS AND CONSIST OF A SINGLE LAYER 1/2" THICK X 1'-0" WIDE X 4'-2 1/2" LONG. THE PAD SHALL EXTEND 1/2" BEYOND THE END OF THE BEAM AS SHOWN. THE TOP SURFACE OF THE BEAM BELOW THE ELASTOMERIC PAD SHALL HAVE A SMOOTH FINISH.

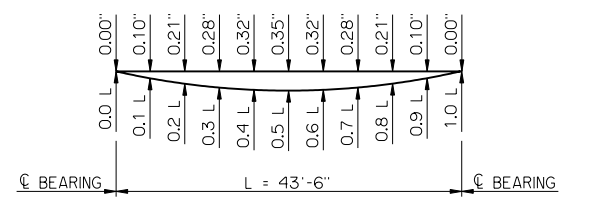

**DEAD LOAD DEFLECTIONS**

THE DEAD LOAD DEFLECTIONS SHOWN ABOVE AT THE TENTH POINTS ARE THE INITIAL THEORETICAL BEAM DEFLECTIONS DUE TO THE DIAPHRAGMS, 5 PSF DECK FORM ALLOWANCE, DECK SLAB, HAUNCH AND CONCRETE TRAFFIC RAIL (TR3). THE DEAD LOAD DEFLECTIONS SHALL BE ACCOUNTED FOR IN THE HAUNCH DEPTH CALCULATIONS.

**MATERIAL PROPERTIES**

THE COMPRESSIVE STRENGTH OF THE CONCRETE IN THE P.C. BEAM SHALL BE NO LESS THAN 4,500 PSI AT THE TIME OF TRANSFER OF THE PRESTRESSING FORCE AND NO LESS THAN 6,000 PSI AT 28 DAYS AFTER THE POURING OF THE CONCRETE.

THE TYPE OF PRESTRESSING STRANDS REQUIRED IN THE P.C. BEAM SHALL BE LOW RELAXATION 7-WIRE STRAND WITH A NOMINAL DIAMETER OF 0.6 INCHES AND AN ULTIMATE TENSILE STRENGTH OF 270 KSI.

**LFD OPERATING RATING - HS 32.9**

THE LFD OPERATING RATING SHOWN ABOVE IS FOR THE P.C. BEAM ONLY AND APPLIES ONLY TO THE P.C. BEAMS OF A BRIDGE CONSTRUCTED IN STRICT CONFORMANCE TO ALL RELEVANT DETAILS CONTAINED IN THE COMPLETE SET OF COUNTY BRIDGE STANDARDS AND TO THE ODOT STANDARD SPECIFICATIONS.

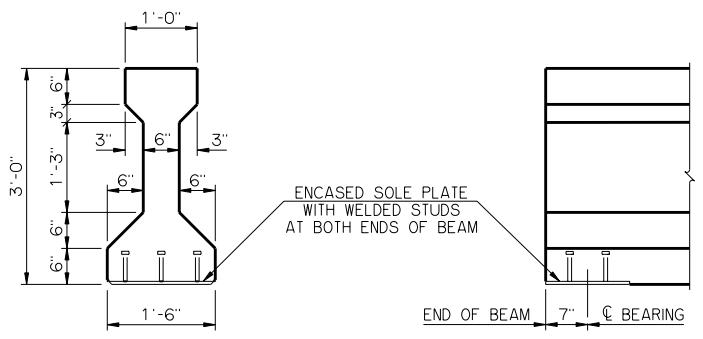

**END VIEW**  
ELASTOMERIC PAD NOT SHOWN

**END ELEVATION**  
ELASTOMERIC PAD NOT SHOWN

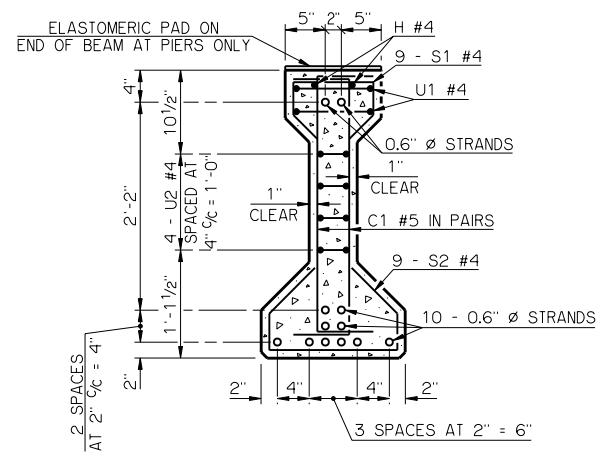

**END SECTION**

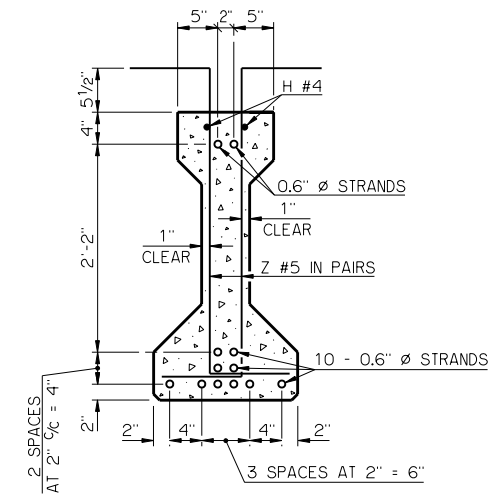

**SECTION**

**BEAM SECTIONS**  
(12 - 0.6" diameter strands)

APPROVED BY BRIDGE ENGINEER *Robert J. Rusch* DATE 10/16/05  
 OKLAHOMA DEPARTMENT OF TRANSPORTATION  
 COUNTY BRIDGE STANDARD (ENGLISH)  
**P.C. BEAM DETAILS**  
**TYPE II - 45' SPAN**  
 32' CLEAR ROADWAY - INTEGRAL - SKEWED 0°  
 1999 STANDARD SPECIFICATIONS      CB32-I-SKO-PCB-II-45      OOE  
 CB-780E