

DIAPHRAGM ROD HOLE SCHEDULE				
BRIDGE SKEW	θ	L1	L2	L3
0°	90°	10 1/2"	36'-5 1/2"	0'-0"
30° LEFT FORWARD	60°	1'-0"	33'-8 1/4"	5'-3 1/2"
30° RIGHT FORWARD	120°	1'-0"	33'-8 1/4"	5'-3 1/2"

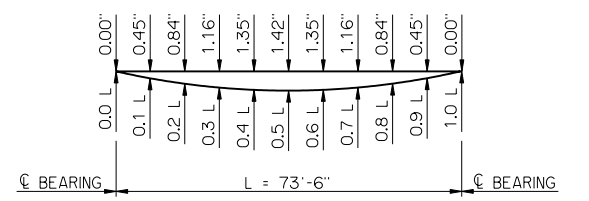

DEAD LOAD DEFLECTIONS
 THE DEAD LOAD DEFLECTIONS SHOWN ABOVE AT THE TENTH POINTS ARE THE INITIAL THEORETICAL BEAM DEFLECTIONS DUE TO THE DIAPHRAGMS, 5 PSF DECK FORM ALLOWANCE, DECK SLAB, HAUNCH AND CONCRETE TRAFFIC RAIL (TR3). THE DEAD LOAD DEFLECTIONS SHALL BE ACCOUNTED FOR IN THE HAUNCH DEPTH CALCULATIONS.

MATERIAL PROPERTIES
 THE COMPRESSIVE STRENGTH OF THE CONCRETE IN THE P.C. BEAM SHALL BE NO LESS THAN 6,300 PSI AT THE TIME OF TRANSFER OF THE PRESTRESSING FORCE AND NO LESS THAN 9,000 PSI AT 28 DAYS AFTER THE POURING OF THE CONCRETE.

LFD OPERATING RATING - HS 39.2
 THE LFD OPERATING RATING SHOWN ABOVE IS FOR THE P.C. BEAM ONLY AND APPLIES ONLY TO THE P.C. BEAMS OF A BRIDGE CONSTRUCTED IN STRICT CONFORMANCE TO ALL RELEVANT DETAILS CONTAINED IN THE COMPLETE SET OF COUNTY BRIDGE STANDARDS AND TO THE ODOT STANDARD SPECIFICATIONS.

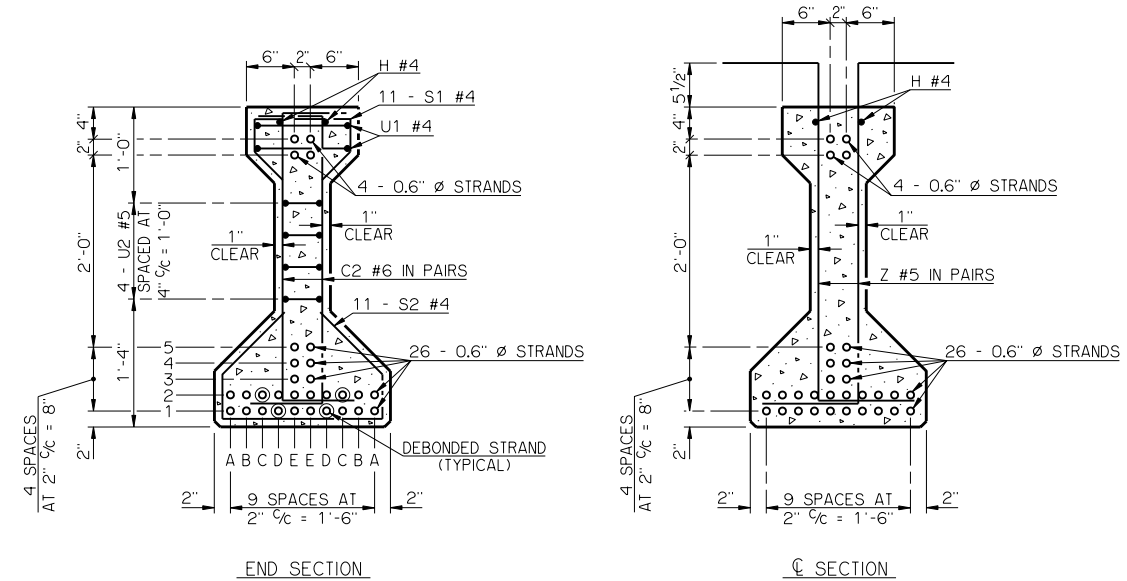
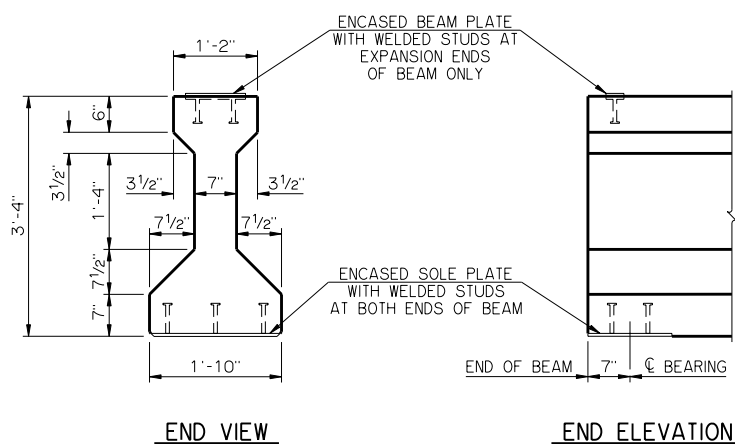

BEAM SECTIONS
 (30 - 0.6" STRANDS)

DEBOND SCHEDULE	
DEBOND PAIR	DEBOND LENGTH FROM END OF BEAM
D1	7'-0"
C2	22'-0"

APPROVED BY BRIDGE ENGINEER *Robert J. Rusch* DATE 10/16/06
 OKLAHOMA DEPARTMENT OF TRANSPORTATION
 COUNTY BRIDGE STANDARD (ENGLISH)
P.C. BEAM DETAILS
TYPE C - 75' SPAN
32' CLEAR ROADWAY - CONVENTIONAL - SKEWED 0° AND 30°
 1999 STANDARD SPECIFICATIONS CB32-C-SKO.30-PCB-C-75 OOE
 CB-664E