

DEAD LOAD DEFLECTION DIAGRAM

ELEVATION

BRIDGE SKEW 30° LEFT FORWARD IS SHOWN IN DRAWING.

SPAN	BEAM	BEAM LENGTH	BRIDGE SKEW								N1	S1	L1	S2	N3	S3	L3	BEARING STIFFENER	LFD OPERATING RATING ①	MAXIMUM (ADTT) ₅₀ ALLOWABLE ②
			0°		30° LEFT FORWARD		30° RIGHT FORWARD													
			B	C	B	C	B	C												
55'	W33 X 118	54'-8"	17'-10"	17'-10"	17'-10"	17'-10"	14'-10 1/2"	20'-9 1/2"	20'-9 1/2"	14'-10 1/2"	22	6"	11'-0"	0"	54	7"	31'-6"	IP 3/4" X 5"	HS 30.2	506
60'	W36 X 135	59'-8"	19'-6"	19'-6"	19'-6"	16'-6 1/2"	22'-5 1/2"	22'-5 1/2"	16'-6 1/2"	36	6"	18'-0"	7"	32	8"	21'-4"	IP 3/4" X 5"	HS 32.2	549	
65'	W36 X 150	64'-8"	21'-2"	21'-2"	21'-2"	18'-2 1/2"	24'-1 1/2"	24'-1 1/2"	18'-2 1/2"	39	6"	19'-6"	7"	35	8"	23'-4"	IP 3/4" X 5"	HS 31.8	502	
70'	W36 X 160	69'-8"	22'-10"	22'-10"	22'-10"	19'-10 1/2"	25'-9 1/2"	25'-9 1/2"	19'-10 1/2"	30	6"	15'-0"	0"	66	7"	38'-6"	IP 3/4" X 5"	HS 28.2	416	
75'	W40 X 183	74'-8"	24'-6"	24'-6"	24'-6"	21'-6 1/2"	27'-5 1/2"	27'-5 1/2"	21'-6 1/2"	45	6"	22'-6"	7"	41	8"	27'-4"	IP 3/4" X 5"	HS 33.2	534	

SPAN	BEAM AND DIAPHRAGM DEFLECTION					
	CL BEARING	.1 AND .9	.2 AND .8	.3 AND .7	.4 AND .6	.5
55'	0.00"	0.04"	0.08"	0.10"	0.12"	0.13"
60'	0.00"	0.05"	0.09"	0.13"	0.15"	0.16"
65'	0.00"	0.07"	0.12"	0.17"	0.20"	0.21"
70'	0.00"	0.09"	0.17"	0.23"	0.27"	0.28"
75'	0.00"	0.10"	0.19"	0.25"	0.30"	0.31"

SPAN	DECK FORMS, DECK SLAB, HAUNCH, AND TRAFFIC RAIL DEFLECTION ③					
	CL BEARING	.1 AND .9	.2 AND .8	.3 AND .7	.4 AND .6	.5
55'	0.00"	0.35"	0.66"	0.90"	1.05"	1.10"
60'	0.00"	0.38"	0.71"	0.97"	1.14"	1.20"
65'	0.00"	0.45"	0.85"	1.17"	1.37"	1.44"
70'	0.00"	0.57"	1.07"	1.47"	1.72"	1.81"
75'	0.00"	0.55"	1.05"	1.44"	1.68"	1.77"

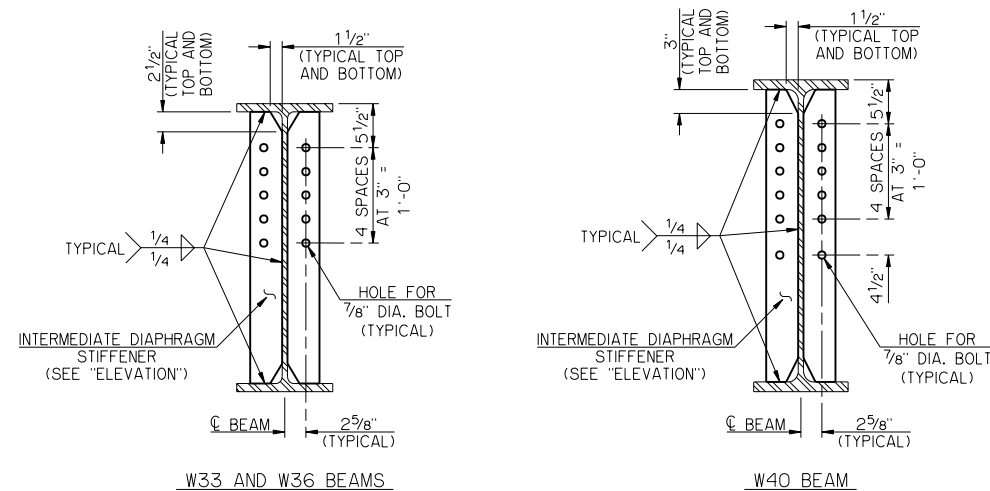

INTERMEDIATE DIAPHRAGM STIFFENER DETAILS

DETAILS SHOWN AT INTERIOR BEAM. OMIT INTERMEDIATE DIAPHRAGM STIFFENERS AT OUTSIDE FACE OF EXTERIOR BEAMS.

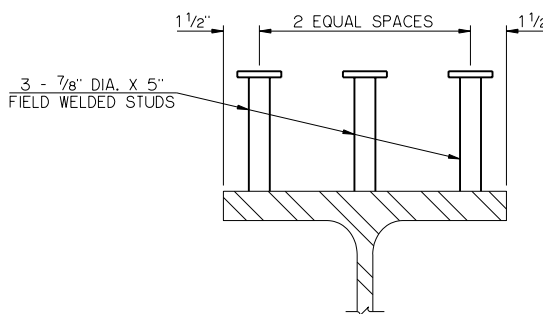

SHEAR CONNECTOR DETAIL

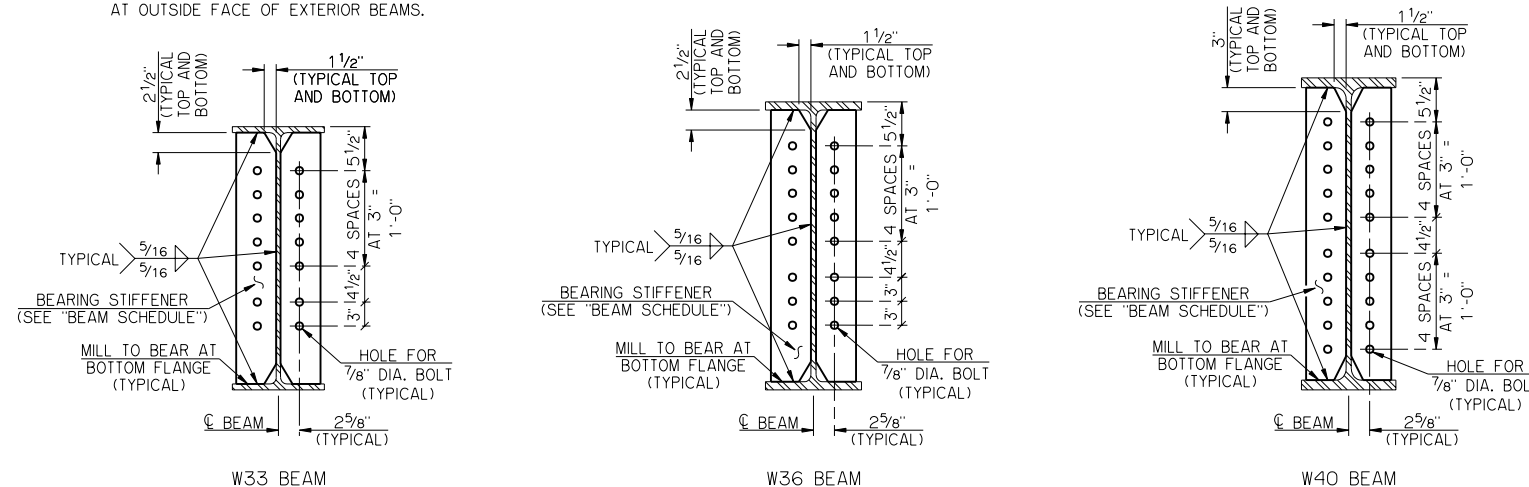

BEARING STIFFENER DETAILS

DETAILS SHOWN AT INTERIOR BEAM. OMIT BOLT HOLES ONLY IN BEARING STIFFENERS AT OUTSIDE FACE OF EXTERIOR BEAMS.

- ① THE LFD OPERATING RATING SHOWN IN THE TABLE IS FOR THE ROLLED BEAMS ONLY AND APPLIES ONLY TO THE ROLLED BEAMS OF A BRIDGE CONSTRUCTED IN STRICT CONFORMANCE TO ALL RELEVANT DETAILS CONTAINED IN THE COMPLETE SET OF COUNTY BRIDGE STANDARDS AND TO THE ODOT STANDARD SPECIFICATIONS.
- ② THIS STANDARD SHALL NOT BE USED IF THE (ADTT)₅₀ EXCEEDS THE VALUE SHOWN IN THE TABLE. THE (ADTT)₅₀ IS THE NUMBER OF TRUCKS PER DAY TRAVELING THE BRIDGE IN ONE DIRECTION AVERAGED OVER A 75-YEAR DESIGN LIFE. A TRUCK IS DEFINED AS ANY VEHICLE HAVING MORE THAN EITHER TWO AXLES OR FOUR WHEELS.
- ③ THE DEAD LOAD DEFLECTIONS SHOWN AT THE TENTH POINTS ARE THE THEORETICAL BEAM DEFLECTIONS DUE TO THE 5 PSF DECK FORM ALLOWANCE, DECK SLAB, HAUNCH AND CONCRETE TRAFFIC RAIL (TR3). THE DEAD LOAD DEFLECTIONS SHALL BE ACCOUNTED FOR IN THE HAUNCH DEPTH CALCULATIONS.

NOTES

STRUCTURAL STEEL FOR ROLLED BEAM AND ALL STIFFENER PLATES SHALL CONFORM TO AASHTO M270 (ASTM A709), GRADE 50W22 (WEATHERING STEEL, NON-FRACTURE CRITICAL CHARPY V-NOTCH TESTED FOR ZONE 2). SHEAR CONNECTORS SHALL CONFORM TO AASHTO M169 (ASTM A108), GRADE 1015, 1018 OR 1020. WELDING SHALL HAVE WEATHERING CHARACTERISTICS.

BEAMS SHALL BE CAMBERED TO ACCOUNT FOR VERTICAL CURVE, IF NECESSARY. IF CAMBERING IS NOT REQUIRED, PLACE NATURAL CAMBER UP.

CONTRACTOR MAY ELECT TO FABRICATE PLATE GIRDERS USING EQUIVALENT PLATE SIZES IN LIEU OF ROLLED BEAM SHAPE SHOWN. WEB TO FLANGE WELDS SHALL BE MINIMUM 5/16" FILLET WELDS. NON-DESTRUCTIVE TESTING WILL BE REQUIRED AS APPROPRIATE. COSTS TO CONSTRUCT PLATE GIRDERS SHALL BE AT THE CONTRACTOR'S EXPENSE.

TERMINATE FILLET WELDS 3/8" FROM THE EDGE OF CLIPPED CORNERS OF ALL STIFFENER PLATES AND NON-CLIPPED CORNERS OF INTERMEDIATE DIAPHRAGM STIFFENERS. WRAP FILLET WELD AROUND NON-CLIPPED CORNERS OF BEARING STIFFENERS.

FOR ADDITIONAL DETAILS, SEE "DIAPHRAGM DETAILS."

APPROVED BY BRIDGE ENGINEER *Robert J. Rusch* DATE 10/16/08

OKLAHOMA DEPARTMENT OF TRANSPORTATION
COUNTY BRIDGE STANDARD (ENGLISH)

ROLLED BEAM DETAILS
55' THRU 75' SPANS

26' CLEAR ROADWAY - CONVENTIONAL - SKEWED 0° AND 30°

1999 STANDARD SPECIFICATIONS CB26-C-SKO..30-RB-5575 OOE CB-324E