

PLAN

PEDESTAL DIMENSIONS		
BEAM TYPE	P1	P2
TYPE II	2"	4 <sup>7</sup> / <sub>16</sub> "
TYPE B	4"	6 <sup>7</sup> / <sub>16</sub> "

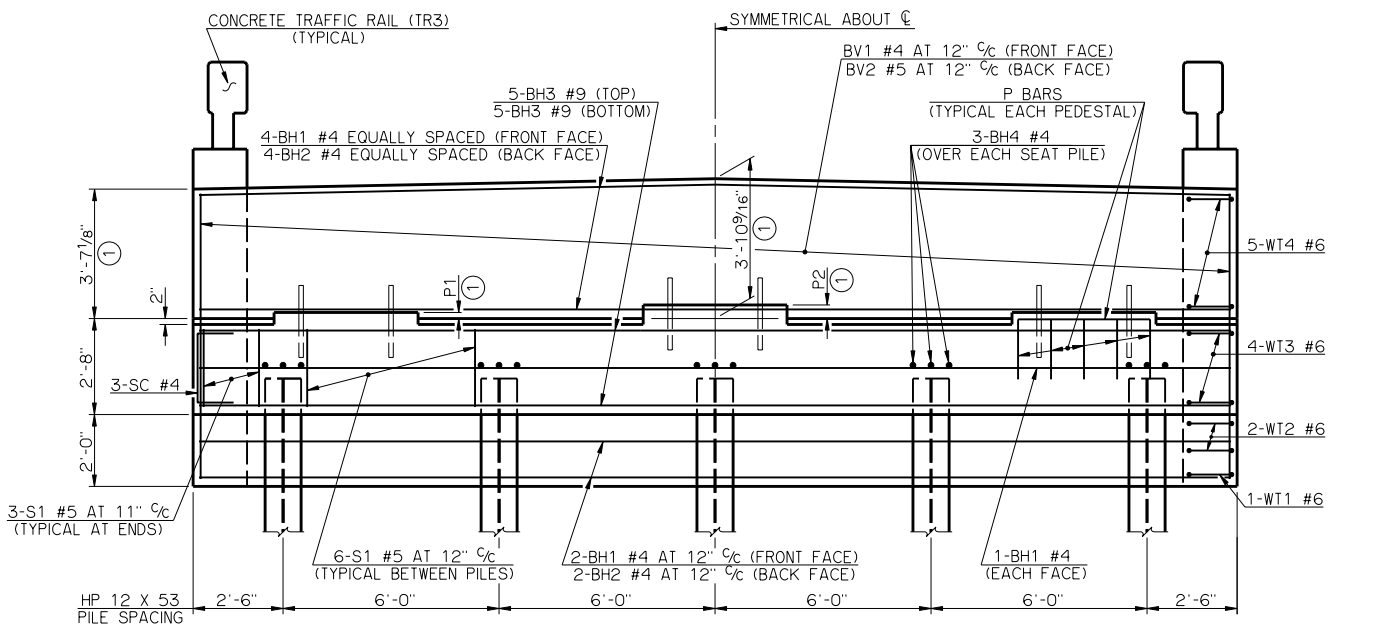

ELEVATION

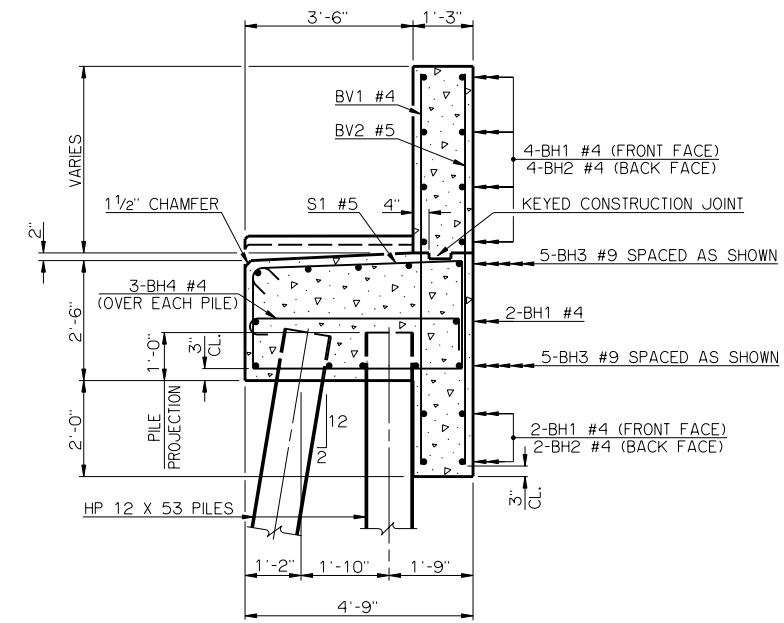

TYPICAL SECTION THRU ABUTMENT

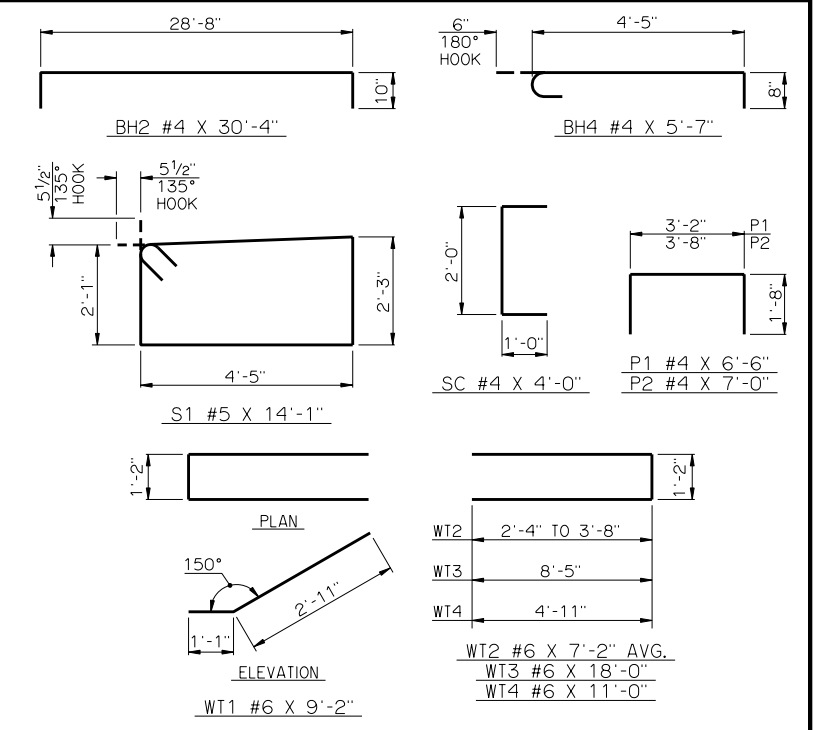

DETAILS OF BENT REINFORCING STEEL

BAR LIST - ONE ABUTMENT					
MARK	NO.	SIZE	FORM	LENGTH	LENGTH VARIATION
BH1	8	#4	STR.	28'-8"	-
BH2	6	#4	BNT.	30'-4"	-
BH3	10	#9	STR.	28'-8"	-
BH4	15	#4	BNT.	5'-7"	-
BV1	30	#4	STR.	8'-0" AVG.	7'-10" TO 8'-2"
BV2	30	#5	STR.	8'-0" AVG.	7'-10" TO 8'-2"
P1	15	#4	BNT.	6'-6"	-
P2	12	#4	BNT.	7'-0"	-
S1	30	#5	BNT.	14'-1"	-
SC	6	#4	BNT.	4'-0"	-
WT1	2	#6	BNT.	9'-2"	-
WT2	4	#6	BNT.	7'-2" AVG.	5'-10" TO 8'-6"
WT3	8	#6	BNT.	18'-0"	-
WT4	10	#6	BNT.	11'-0"	-

③ NO. INCLUDES TWO SETS OF 15 BARS  
 ④ NO. INCLUDES TWO SETS OF 2 BARS

SUMMARY OF QUANTITIES - ONE ABUTMENT ⑤		
ITEM	UNIT	TOTAL
SUBSTRUCTURE EXCAVATION COMMON	CY	60.00
GRANULAR BACKFILL	CY	33.00
CLASS A CONCRETE	CY	21.80
REINFORCING STEEL	LB	2,750.00
PILES, FURNISHED (HP 12 x 53)	LF	-
PILES, DRIVEN (HP 12 x 53)	LF	-
6" PERFORATED PIPE UNDERDRAIN ROUND	LF	26.00
6" NON-PERF. PIPE UNDERDRAIN RND.	LF	-

⑤ EXCLUDES WINGS

① DIMENSIONS ARE FROM TOP OF BRIDGE SEAT AT FRONT FACE OF BACKWALL.  
 ② ALL WT WING REINFORCING STEEL TIED TO THE ABUTMENT BRIDGE SEAT, BACKWALL AND CURTAIN WALL REINFORCING STEEL MUST BE IN PLACE PRIOR TO POURING ABUTMENT CONCRETE. FOR ADDITIONAL INFORMATION SEE WING DETAILS.

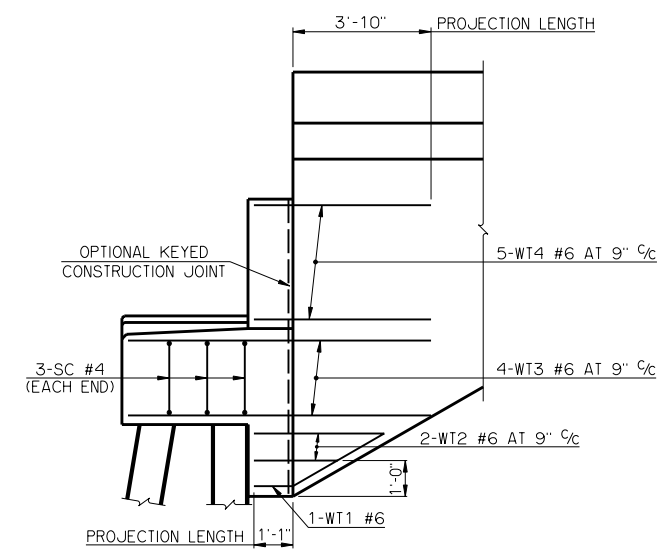

SIDE VIEW

APPROVED BY BRIDGE ENGINEER *Robert J. Rusch* DATE 10/16/05  
 OKLAHOMA DEPARTMENT OF TRANSPORTATION  
 COUNTY BRIDGE STANDARD (ENGLISH)  
**ABUTMENT DETAILS**  
**TYPE II AND TYPE B P.C. BEAMS**  
**26' CLEAR ROADWAY - CONVENTIONAL - SKEWED 0°**  
 1999 STANDARD SPECIFICATIONS CB26-C-SKO-ABUT-PC2 OOE  
 CB-150E