

**DESIGN DATA**  
 LOADING: HS 20-44  
 CONCRETE:  $f_c = 6,000$  psi  
 $f_{ci} = 4,500$  psi

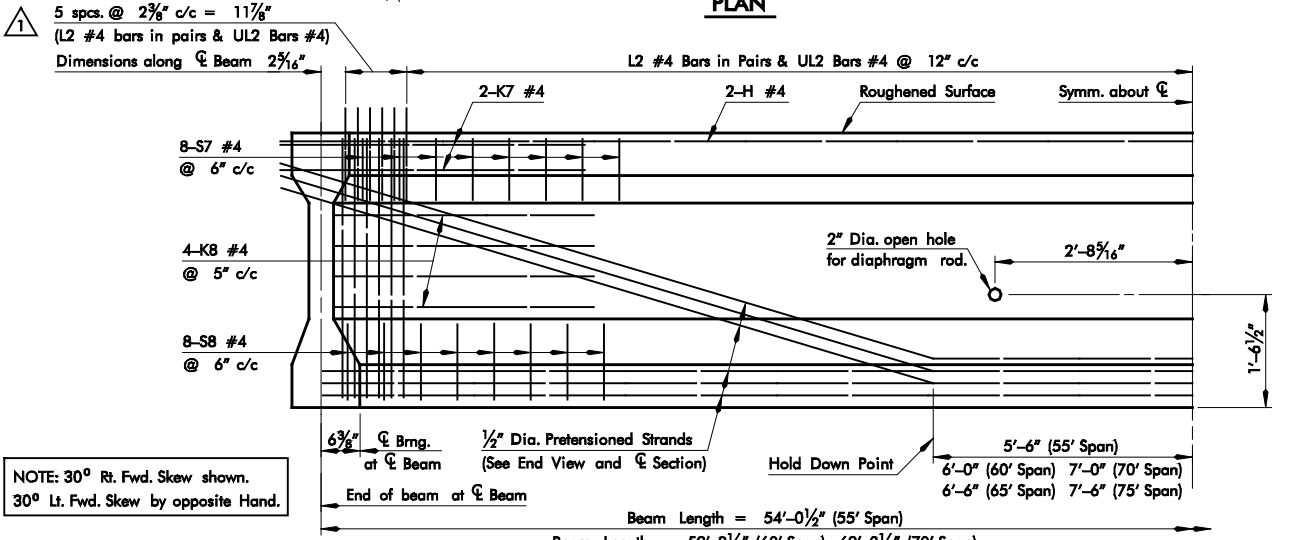

NOTE: 30° Rt. Fwd. Skew shown.  
 30° Lt. Fwd. Skew by opposite Hand.

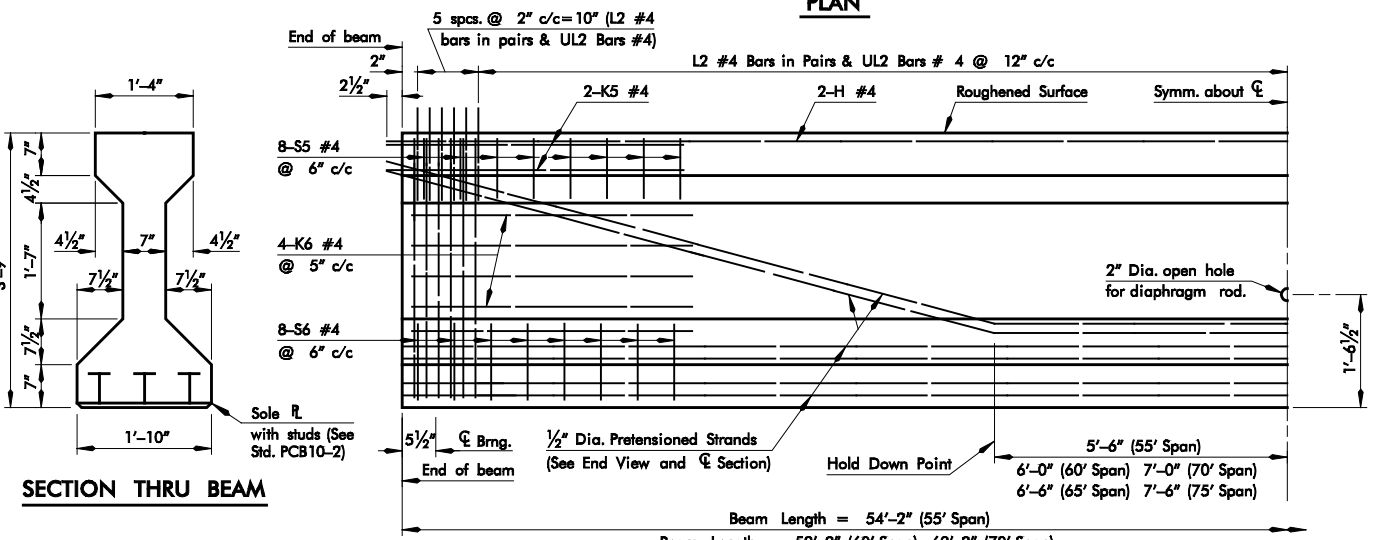
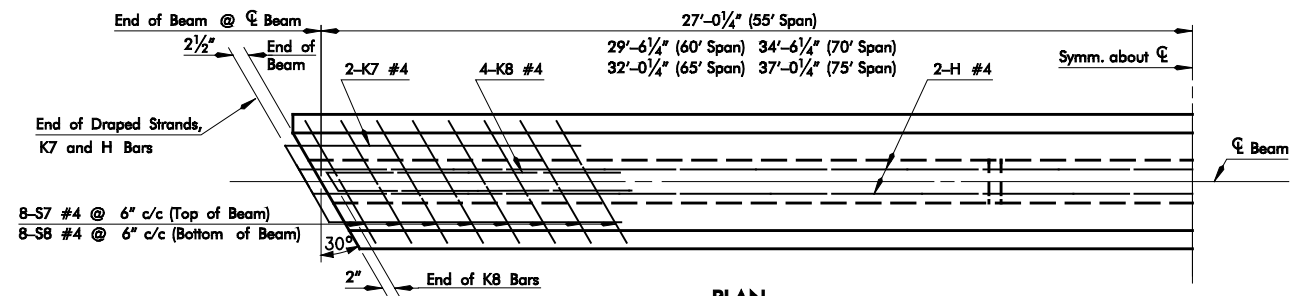
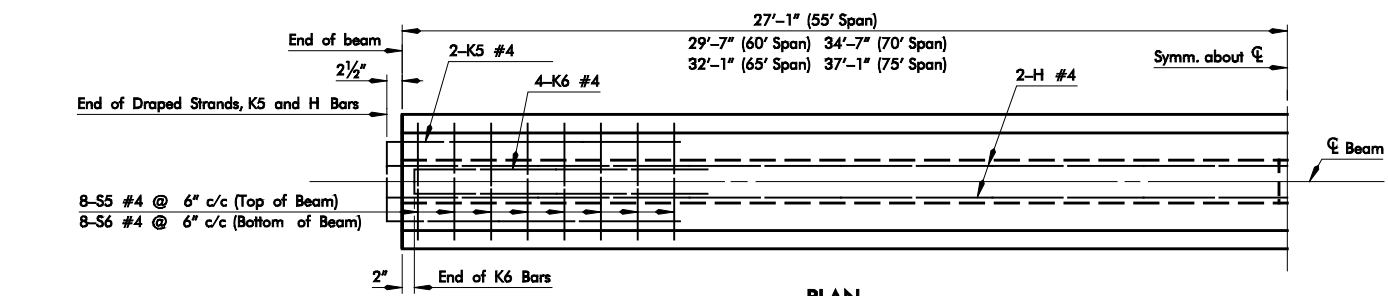
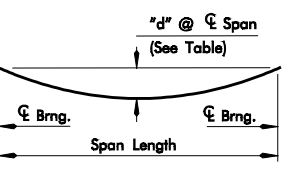

**DEAD LOAD DEFLECTION DIAGRAM**

SPAN	DEAD LOAD DEFLECTION "d"	OPERATING RATING
55'	3/8"	HS 41
60'	1/2"	HS 44
65'	3/4"	HS 47
70'	1 1/16"	HS 50
75'	1 1/4"	HS 51

**SECTION THRU BEAM**

**ELEVATION - 0° SKEW**

**ELEVATION - 30° SKEW**

**GENERAL NOTES**

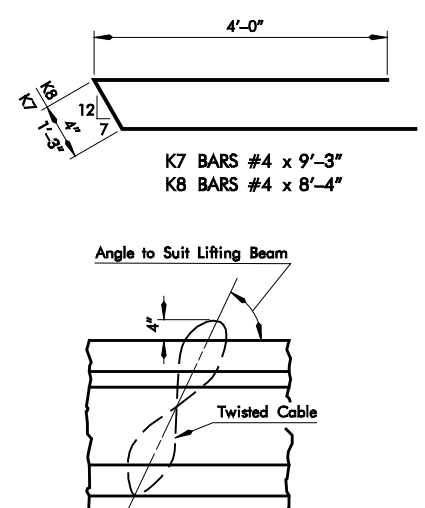
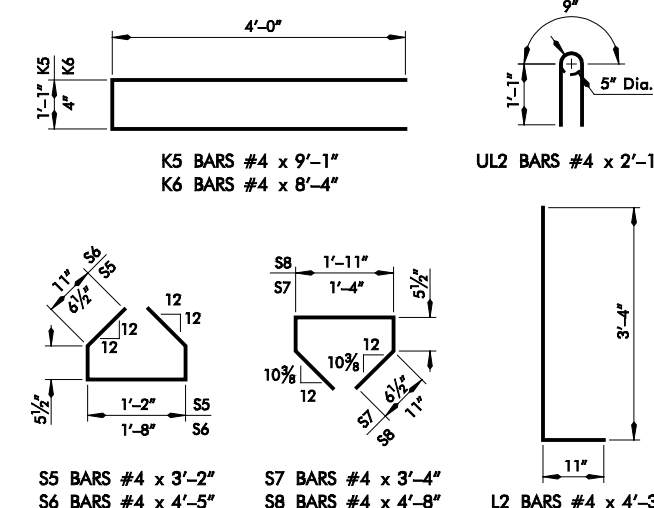
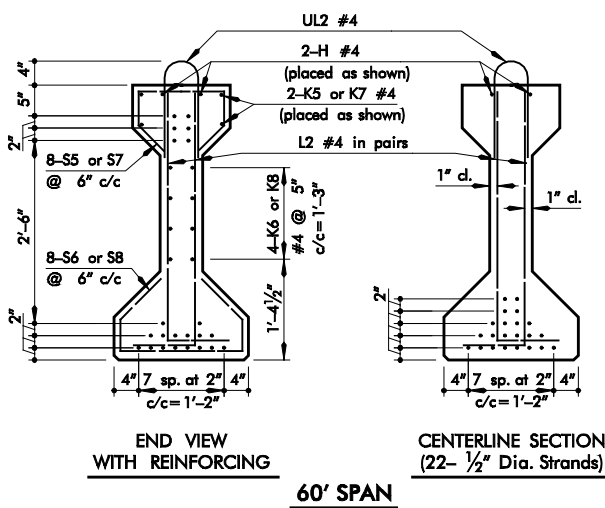
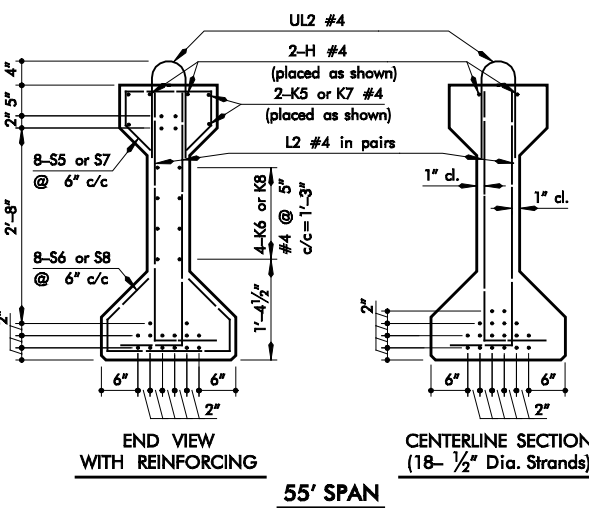

**DETAIL OF LIFTING EYE**

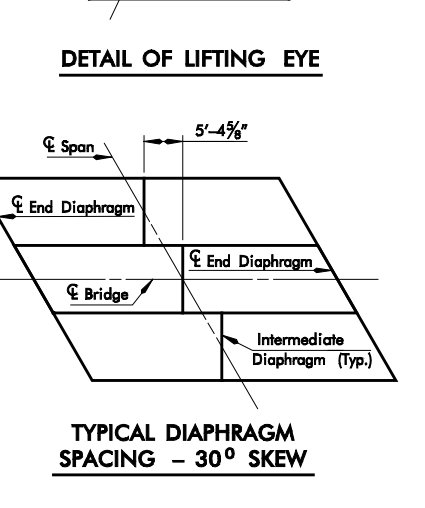
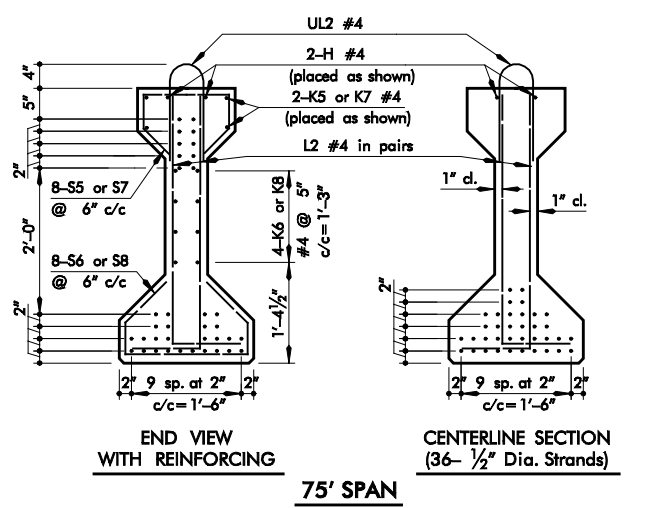
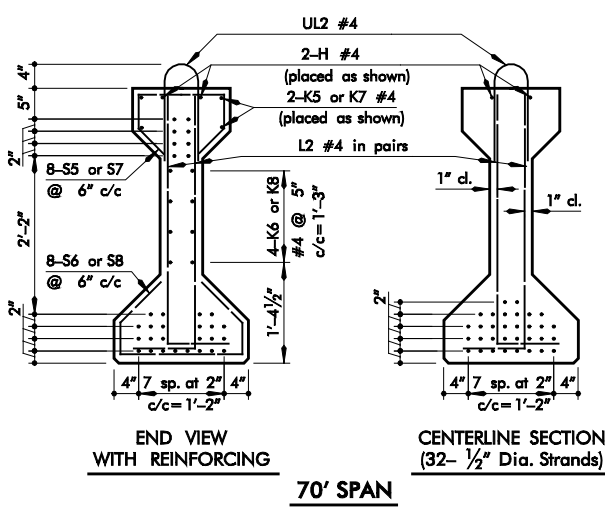
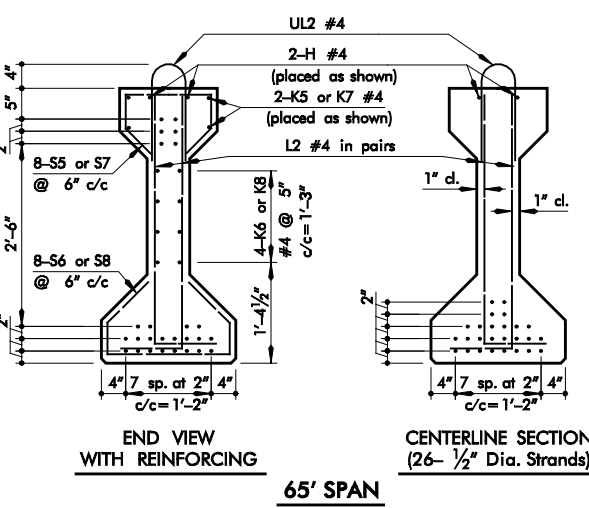

**TYPICAL DIAPHRAGM SPACING - 30° SKEW**

**PRESTRESSED CONCRETE BEAMS:**  
**CHAMFER REQUIREMENT:** Chamfer all exposed edges of P.C. Beams 3/4" unless otherwise noted.  
**FORMS & PALLETS:** All beams shall be cast in concrete floored pallets and metal forms.  
**FINISH:** Top of beams to be rough floated. At approximately the time of initial set, entire top of beam shall be scrubbed transversely with coarse wire brush to remove all laitance and to produce a roughened surface for bonding slab.  
**CONCRETE:** Concrete for beams shall have a min. 6,000 p.s.i. strength at 28 days.  
**CEMENT:** Type I or III Portland Cement may be used for the Prestressed Concrete Beams.  
**CYLINDER STRENGTH:** At transfer of the tensioning load, the cylinder strength of the concrete shall be at least 4,500 p.s.i.  
**HANDLING:** In the handling of the beams, they must be maintained in an upright position at all times and must be picked up from the lifting eye provided at the beam ends. Disregard of this requirement may lead to collapse of the member.  
**SPECIFICATIONS FOR STEEL STRANDS:** Type 270 K, 7-wire, uncoated, low relaxation steel strand shall conform to the requirements of AASHTO M203 (ASTM A-416) and Supplement I.  
**STRAND:** All strands shall be the size and type as shown on the Plans. Initial load per strand shall be 75% of the breaking strength of the strand for low relaxation strand.  
**TREATMENT OF CUT STRANDS:** All non-draped prestressing strands shall be cut off flush with the end of the beam. All cut off strands that will be exposed are to be coated with two coats of an approved zinc rich paint (minimum 6 mils). Painting to be done by fabricator.  
**SHOP DRAWINGS:** The Contractor shall have his Prestressed Concrete Beam Fabricator furnish the Bridge Engineer, for his approval, two sets of checked shop drawings. Shop drawings shall show the casting length center to center of bearings, and the calculated prestress shortening. One copy shall be returned to the fabricator with any desired corrections indicated. The fabricator shall then furnish the Bridge Engineer with as many, generally seven, corrected copies of the shop drawings as may be required for approval and distribution. The approval of the shop drawings in no way relieves the Contractor or his fabricator of the responsibility for mistakes on the shop drawings.

The Prestressed Concrete Beams may be redesigned to use "Debonded" and or 5/8" strands rather than the "Draped" strands shown. The New Design and Structural Calculations for "Debonded" and or 5/8" strands must be prepared by and sealed by a Professional Engineer registered in the State of Oklahoma and submitted to the Bridge Engineer for approval.  
 If "Debonded" Strands are used the "U" bars shall extend on additional 4 feet, toward the middle of the span, just past the point of debonding.

APPROVED BY BRIDGE ENGINEER: \_\_\_\_\_ DATE: \_\_\_\_\_  
 OKLAHOMA DEPT. OF TRANSPORTATION  
 COUNTY BRIDGE STANDARD ( ENGLISH )  
 P.C. BEAM ELEVATIONS AND SECTIONS  
 TYPE III, 32'-9" RDY.