

TACTILE SYSTEM ORIENTATION - TYPICAL CURBED RAMPS

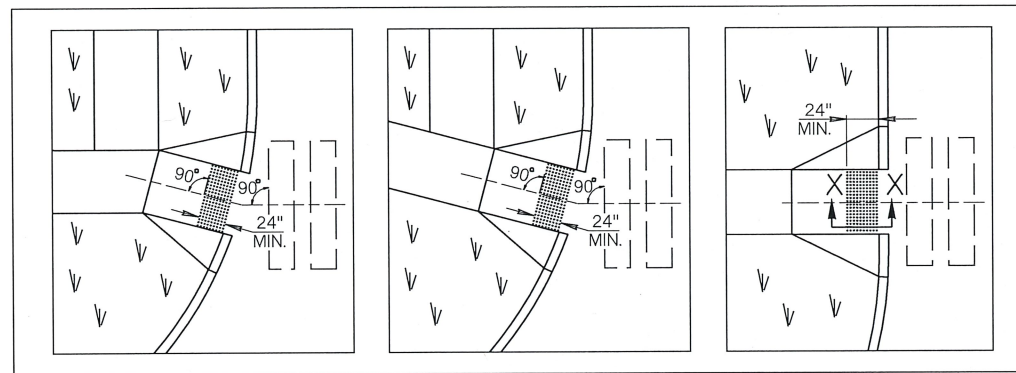

TACTILE SYSTEM ORIENTATION - TYPICAL FLARED RAMPS

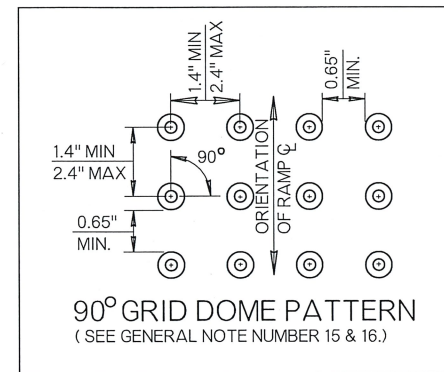
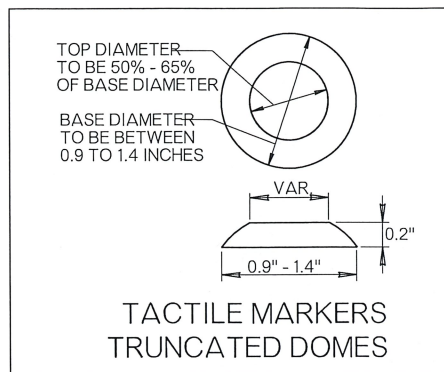

- GENERAL NOTES**
- ALL CONSTRUCTION AND MATERIAL REQUIREMENTS SHALL BE IN ACCORDANCE WITH THE 2009 ODOT STANDARD SPECIFICATIONS.
 - ALL FEATURES OF TACTILE WARNING DEVICE DESIGN AND FINAL INSTALLATION SHALL COMPLY WITH THE PUBLIC RIGHT-OF-WAY ACCESSIBILITY GUIDELINES (PROWAG). WHERE SPATIAL LIMITATIONS OR EXISTING FEATURES WITHIN THE LIMITS OF THE PROJECT PREVENT FULL COMPLIANCE WITH THE PROWAG, THE CONTRACTOR SHALL IMMEDIATELY NOTIFY THE ENGINEER UPON DISCOVERY OF SUCH FEATURE(S). THE CONTRACTOR SHALL NOT PROCEED WITH ANY ASPECT OF THE WORK WHICH IS NOT IN FULL COMPLIANCE WITH THE PROWAG WITHOUT PRIOR WRITTEN APPROVAL FROM THE ENGINEER. ANY WORK WHICH IS NOT PERFORMED WITHIN THE GUIDELINES OF THE PROWAG, FOR WHICH THE CONTRACTOR DOES NOT HAVE WRITTEN APPROVAL, SHALL BE CORRECTED AT THE CONTRACTOR'S EXPENSE.
 - TACTILE WARNING SURFACE SHALL EXTEND FROM EDGE TO EDGE OF WALKWAY ENTERING THE CROSSWALK, AT STREET LEVEL.
 - CURB IS NOT SHOWN IN THE SECTION X-X DETAIL ON THIS SHEET.
 - THICKNESS 'T' OF PAVEMENT ABUTTING SIDEWALK/RAMP VARIES.
 - SIDEWALK, RAMP AND FLARE THICKNESS SHALL BE 4" MINIMUM THICKNESS AFTER INSTALLATION OF TACTILE WARNING TREATMENT.
 - TRUNCATED DOME SURFACE SHALL CONTRAST VISUALLY WITH THE ADJOINING WALKING SURFACES EITHER LIGHT-ON-DARK, OR DARK-ON-LIGHT. THE MATERIAL USED TO PROVIDE CONTRAST SHALL BE AN INTEGRAL PART OF THE TRUNCATED SURFACE.
 - LEVELING SAND FOR DOMED BRICK SYSTEMS SHALL MEET THE REQUIREMENTS OF SECTION 703.06B(2) OF THE SPECIFICATIONS.
 - SURFACE BONDED TACTILE SYSTEMS MAY ONLY BE PLACED ON NEWLY POURED CONCRETE AFTER AN APPROPRIATE PERIOD OF CURING, IN ACCORDANCE WITH MANUFACTURE'S SPECIFICATIONS AND AS DIRECTED BY THE ENGINEER.
 - ROWS OF TACTILE DOME TREATMENT SHOULD BE ORIENTED PARALLEL WITH CENTERLINE OF SIDEWALK/RAMP OR TOWARD THE CENTERLINE OF MARKED CROSSWALK.
 - EXPANSION JOINTS DEEMED NECESSARY, BUT NOT SHOWN ON THE PLANS, MAY BE ADDED AND PLACED DURING CONSTRUCTION, AS DIRECTED BY THE ENGINEER.
 - TACTILE SYSTEMS, DOME PATTERNS OR FEATURES DIFFERING FROM THOSE SHOWN ON THIS DETAIL, BUT MEETING CURRENT PROWAG SPECIFICATIONS, SHALL BE SUBMITTED TO AND APPROVED BY THE ENGINEER BEFORE INSTALLATION.
 - THE SAME TACTILE DOME PATTERN AND COLOR SHALL BE USED THROUGHOUT ANY NEW OR RETROFIT PROJECT. DOME PATTERN & LOCATION OF EXISTING RAMPS TO BE RETROFIT WITH TACTILE DEVICES SHALL BE DESIGNATED ON THE PLANS OR AS DIRECTED BY THE ENGINEER.
 - RETROFIT INSTALLATIONS WILL NOT REQUIRE REPLACING EXISTING DEPRESSED CURBING. A NOMINAL 6 TO 8 INCH SETBACK FROM FACE OF CURB SHALL BE ENFORCED FOR NEAR EDGE OF TACTILE DOMES.
 - TYPES A & B TACTILE SYSTEMS SHALL HAVE A MINIMUM COMPRESSIVE STRENGTH OF 10,000 PSI. TYPES C & D SYSTEMS SHALL HAVE A MINIMUM COMPRESSIVE STRENGTH OF 2000 PSI. COMPRESSIVE TESTS MEET ASTM D695.
 - TACTILE WARNING SURFACES MAY NOT BE STAMPED IN WET CONCRETE.

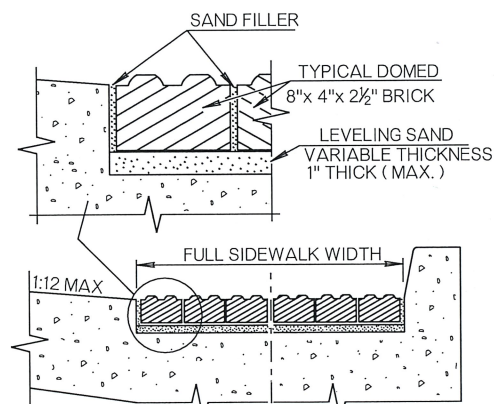

SECTION A - A
FLARED CURBED
DOMED BRICK SYSTEM

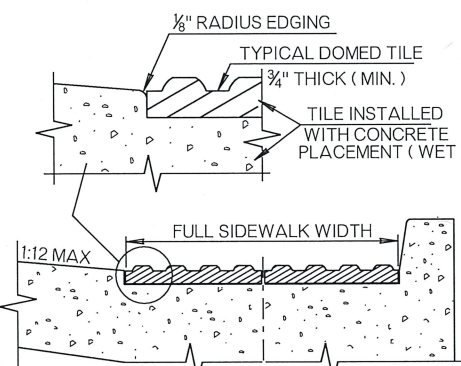

SECTION B - B
FLARED CURBED
DOMED TILE SYSTEM (WET SET INLAY)

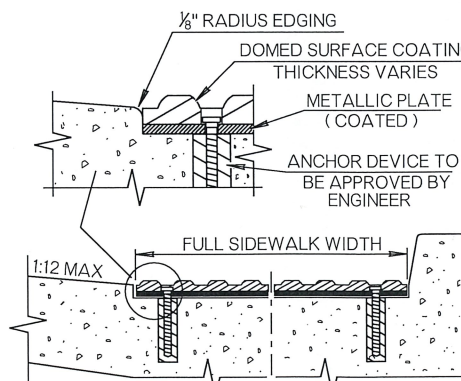

SECTION C - C
FLARED CURBED
DOME COATED PLATE SYSTEM (TYPICAL RETROFIT)

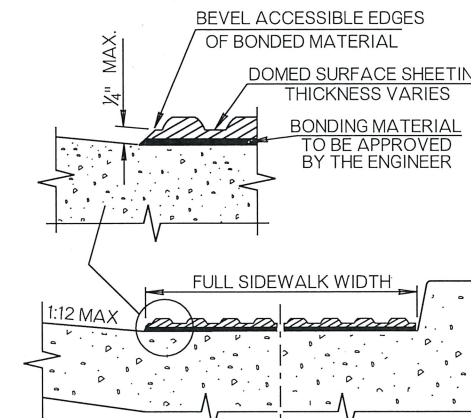

SECTION D - D
FLARED CURBED
SURFACE BONDED DOMED SYSTEM (TYPICAL RETROFIT)

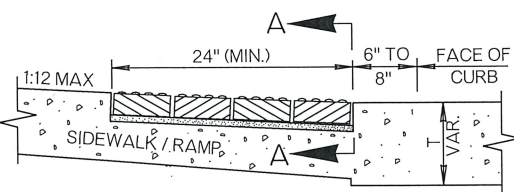

SECTION X - X
TYPE A
DOMED BRICK SYSTEM

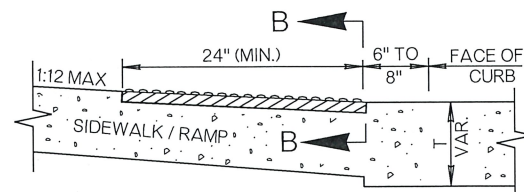

SECTION X - X
TYPE B
DOMED TILE SYSTEM (WET SET INLAY)

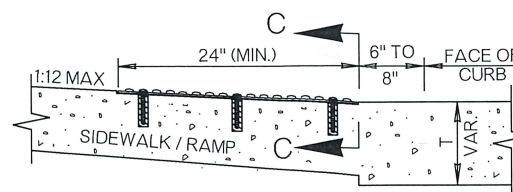

SECTION X - X
TYPE C
DOME COATED PLATE SYSTEM (TYPICAL RETROFIT)

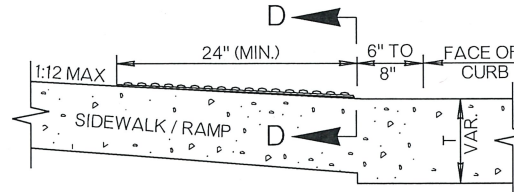

SECTION X - X
TYPE D
SURFACE BONDED DOMED SYSTEM (TYPICAL RETROFIT)

BASIS OF PAYMENT		
ITEM NO.	ITEM	UNIT
610 (1)	TACTILE WARNING DEVICE - NEW	SF
610 (1)	TACTILE WARNING DEVICE - RETROFIT	SF

NOTE: TYPE A OR B TACTILE WARNING DEVICE SHALL BE SPECIFIED ON THE PLANS FOR NEW CONSTRUCTION & TYPE C OR D SHALL BE SPECIFIED ON THE PLANS FOR RETROFIT CONSTRUCTION.

APPROVED BY ROADWAY ENGINEER *Calder A* DATE: 01/23/19
ROADWAY DESIGN DIVISION STANDARD

DOT TACTILE WARNING DEVICES

OKLAHOMA DEPARTMENT OF TRANSPORTATION
2009 SPECIFICATIONS

TWD-1	1
R-23	